

Instruction Manual

# Baron - 4WD Mobile Platform

安装说明书

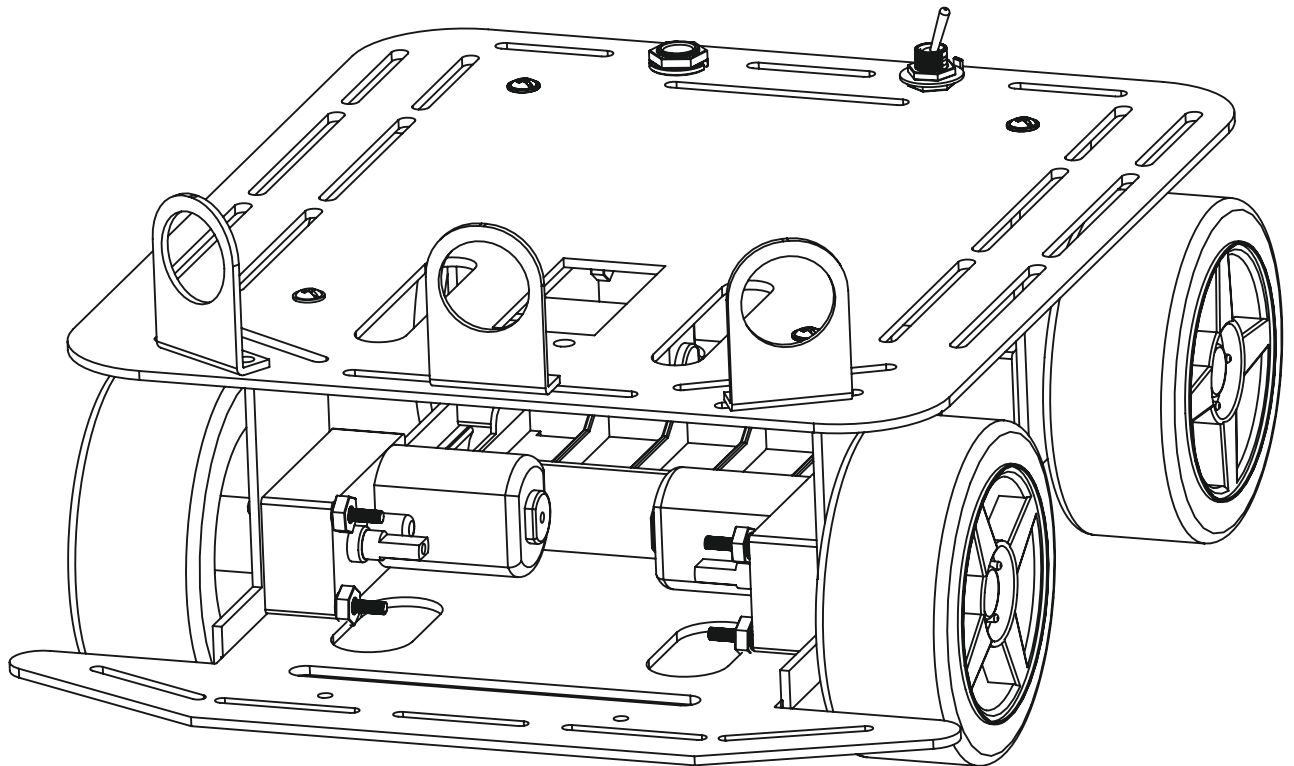

**DFROBOT**

DRIVE THE FUTURE

# 目录 Contents

产品特性 -----	1-2
Features	
产品安装说明-----	3
Notice for Assembly	
电机安装 -----	4
Motors Assembly	
电池盒安装 -----	5
Battery Holder Assembly	
车轮安装-----	6
Wheels Assembly	
开关及插座安装 -----	7
Power Jack and Switch Assembly	
红外传感器支架安装-----	8
IR Sensor Bracket Assembly	
车身上板安装-----	9
Upper Deck Assembly	
编码盘安装-----	10
Encoder Wheel Assembly	
编码器安装-----	11
Encoder Sensor Assembly	
零部件清单-----	12-14
Parts List	

# 产品特性 Features

## 整机尺寸：

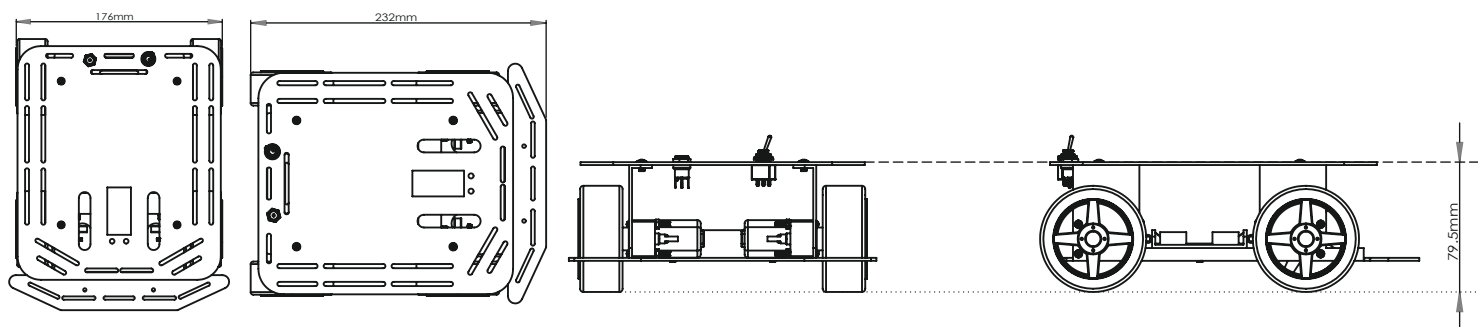

## 简介：

Baron-4WD Mobile Platform四轮驱动机器人是DFRobot研制的机器人实验平台，该平台不但可以用51控制、STC控制器、AVR控制器控制外，更适合使用世界上广泛推广的Arduino控制器，Arduino开放平台拥有全球众多使用者，有丰富的使用例子程序。机身采用高强度铝合金材料，高速电机加优质橡胶轮运动灵活快速，适合室内的平坦路面行进。使用Arduino控制器编程简单，控制起来非常有趣。适合机器人比赛，及其相关研究项目。本小车安装孔兼容多种传感器。

整机重量：614克

车轮直径：65mm

最大行驶速度:61cm/s

## 电机参数：

- 电机供电电压：3-6V
- 堵转电流(3V):260mA
- 减速比：1：120
- 堵转电流(6V):470mA
- 无负载转速(3V):100RPM
- 力矩(3V): 1.2Kgcm
- 无负载转速(6V):200RPM
- 力矩(6V): 1.92Kgcm
- 无负载运行电流(3V):60mA
- 重量:45g
- 无负载运行电流(6V):71mA

# 产品特性 Features

## Dimensions :

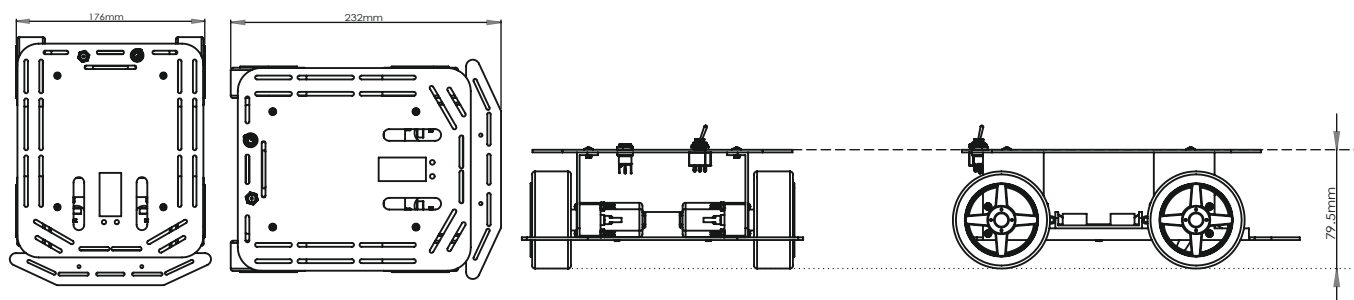

## Introduction :

The Baron four-wheel-drive robot is a DFRobot original design and widely used as self - developed control panel for the Arduino platform. The platform can be controlled by a wide variety of microcontrollers including the widely popular Arduino. The Arduino platform has a large user base which provides a vast amount of resources and sample programs on the internet. The four different drives , powered by high - quality high - speed motors and flexible rubber wheels are mounted on a high - strength aluminum alloy body. This robotic platform is suitable for indoor use or flat road surfaces.

Complete Machine Weight: 614g

Wheel Diameter : 65mm

Highest Speed: 61cm/s

## Motor Feature :

- Gear Ratio : 1:120
- No-load speed (3V): 100RPM
- No-load speed (6V): 200RPM
- No-load current (3V): 60mA
- No-load current (6V): 71mA
- Stall current (3V): 260mA
- Stall current (6V): 470mA
- Torque (3V): 1.2Kgcm
- Torque (6V): 1.92Kgcm
- Weight : 45g

# 产品安装说明 Notice for Assembly

以下设备不包括在ROB0025的部件清单内，用户需自行配备：

1. 5节AA电池。
2. 控制器以及电机驱动器。

您还需要准备以下工具，并参考零部件清单进行ROB0025的安装：

1. 十字螺丝刀（适用于M2.5，M3，M4的螺丝）。
2. 尖嘴钳。

The following parts are not included in the kit :

1. AA battery (5 pieces).
2. Micro-controller and Motor driver.



When beginning assembly, prepare tools below and pick out the parts from the Parts List:

1. Phillips screwdriver ( for screws of M2.5 , M3 , M4 ) .
2. Needle nose pliers.

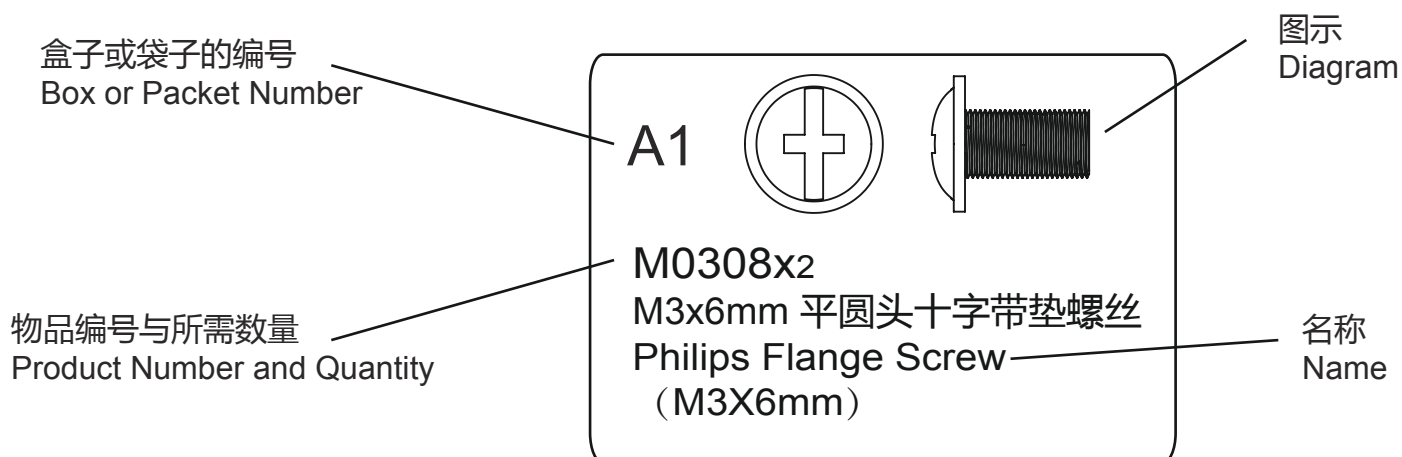
## 标志含义 Symbol Definition

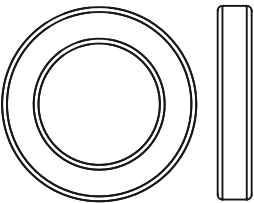
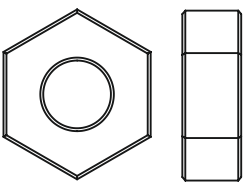

# 电机安装 Motors Assembly

 <p>A1 M2502x2 M2.5mm 垫圈 M2.5mm Washer</p>	 <p>A1 M2504x2 M2.5mm 螺母 M2.5mm Nut</p>	  <p>A1 M2501x2 M2.5x25mm 半圆头十字螺丝 Philips Truss Screw (M2.5X25mm)</p>
---	--	---

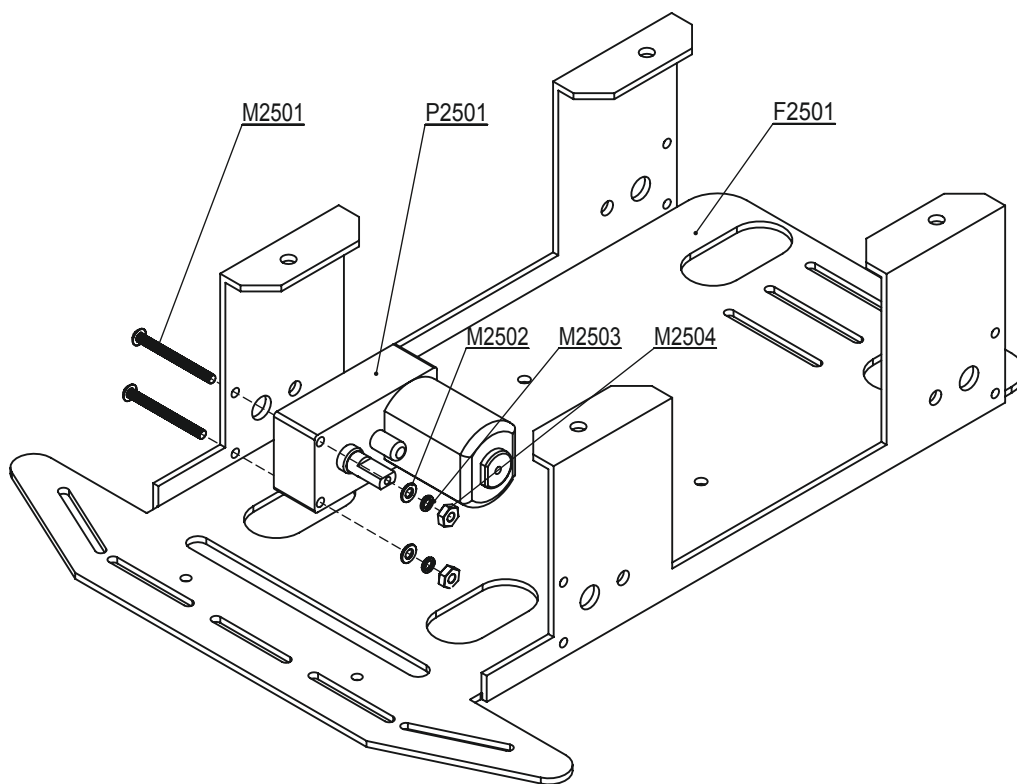

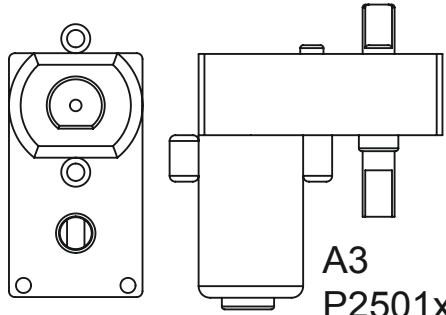
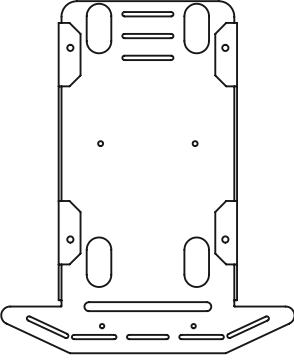
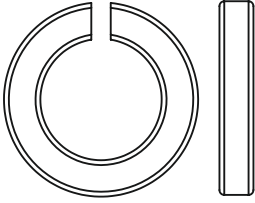
 <p>A3 P2501x1 电机 Motor</p>	 <p>A0 F2501x1 车身下板 Fuselage Base Plate</p>	 <p>A1 M2503x2 M2.5 弹簧垫圈 M2.5 Spring Washer</p>
---	---	--

# 电池盒安装 Battery Holder Assembly

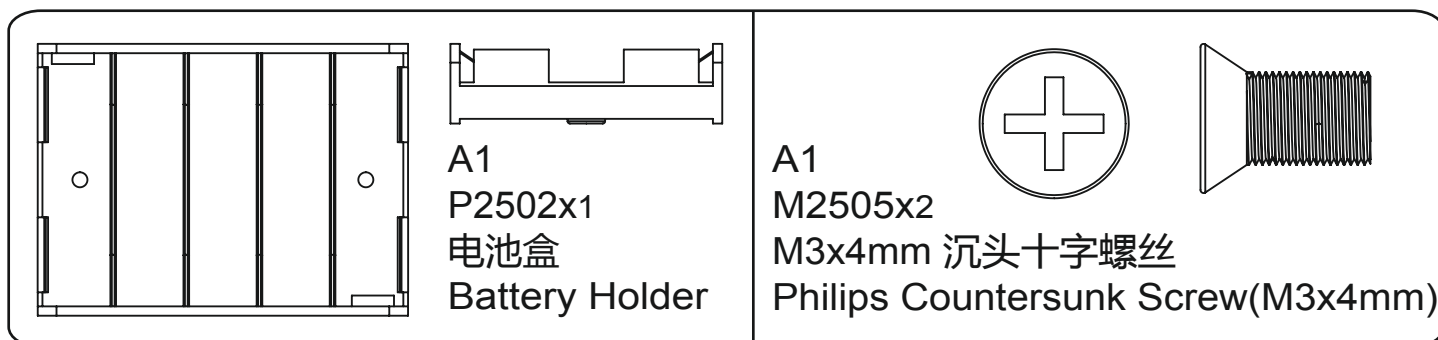
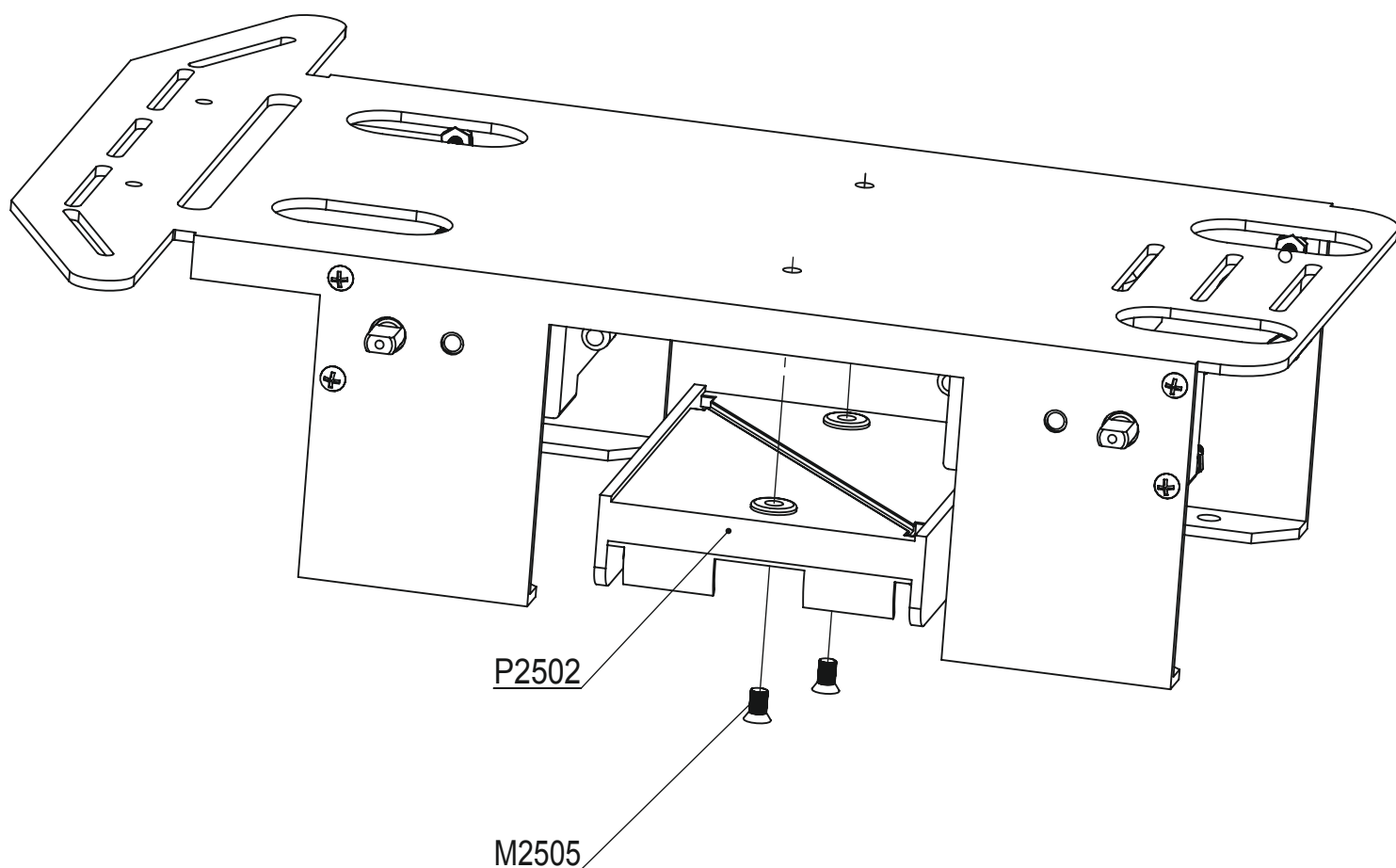

# 轮子安装 Wheels Assembly

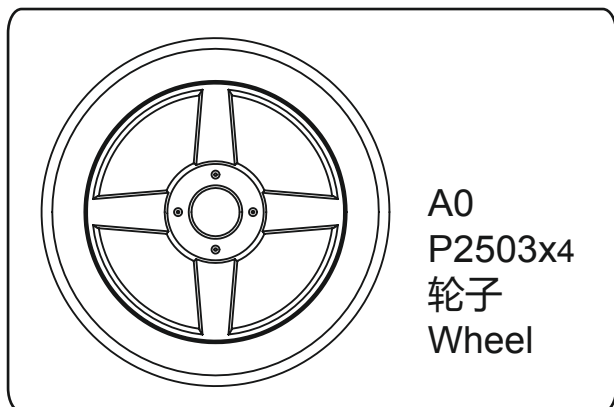
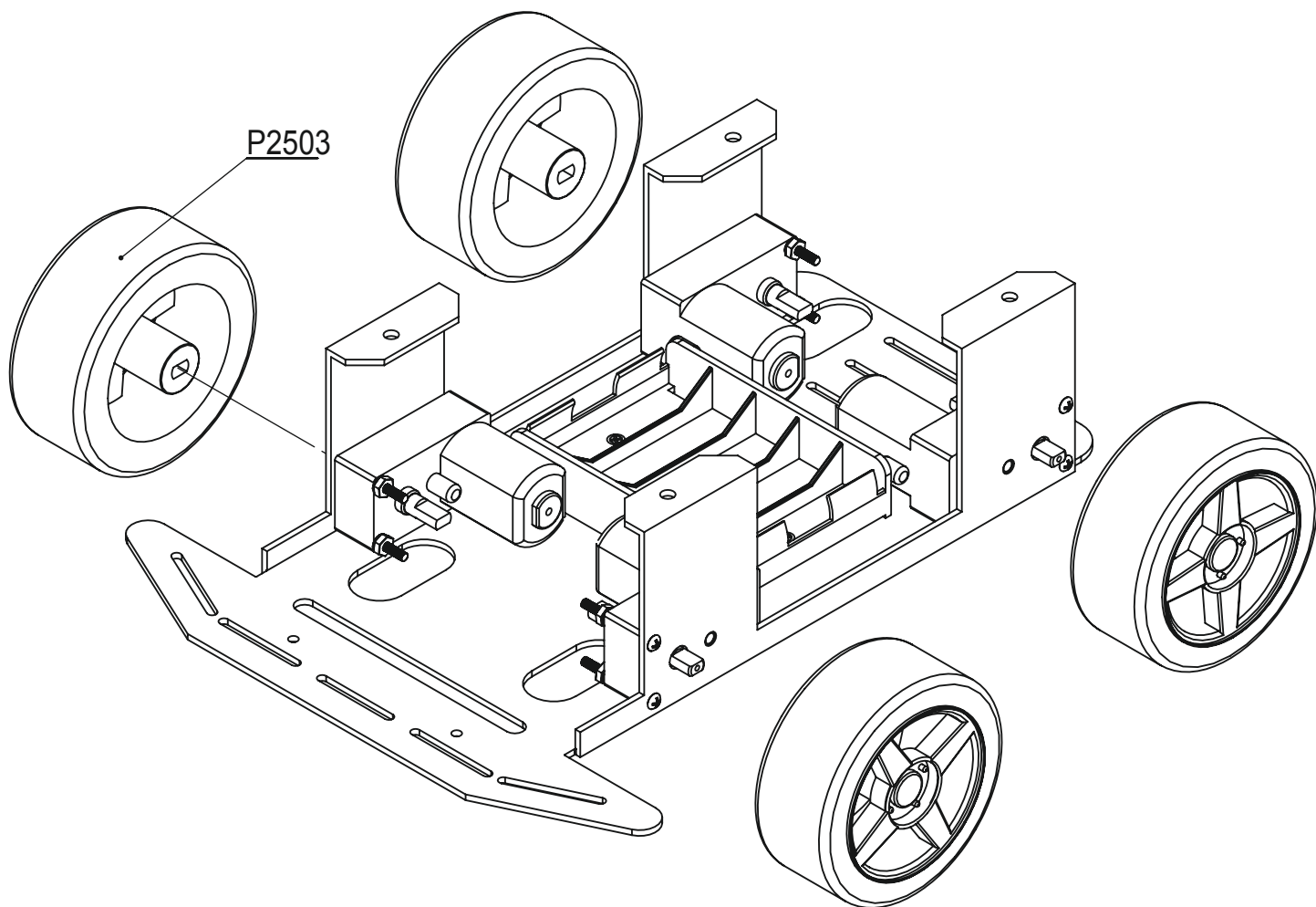

A0  
P2503x4  
轮子  
Wheel



# 开关及插座安装 Power Jack and Switch Assembly

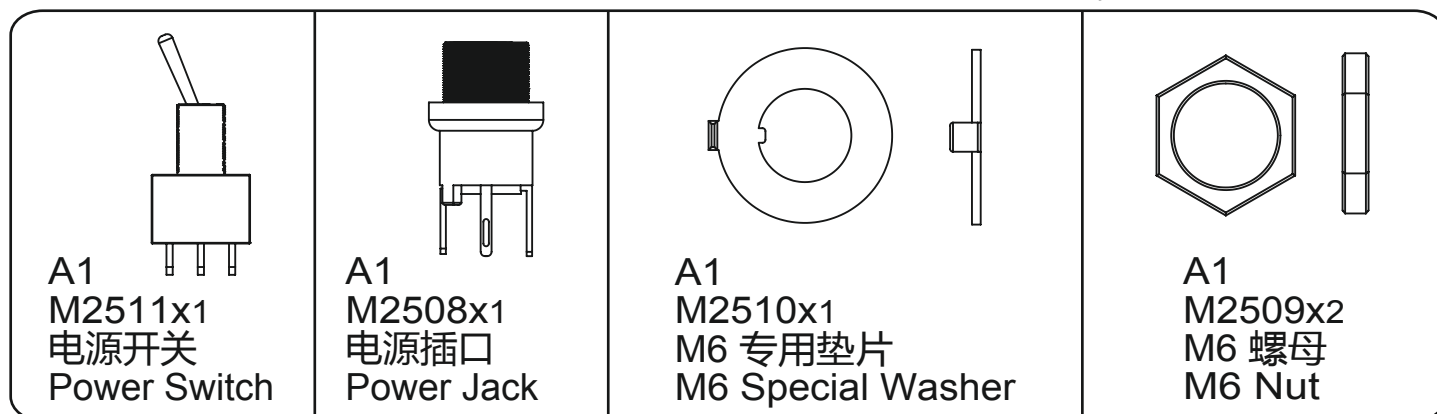
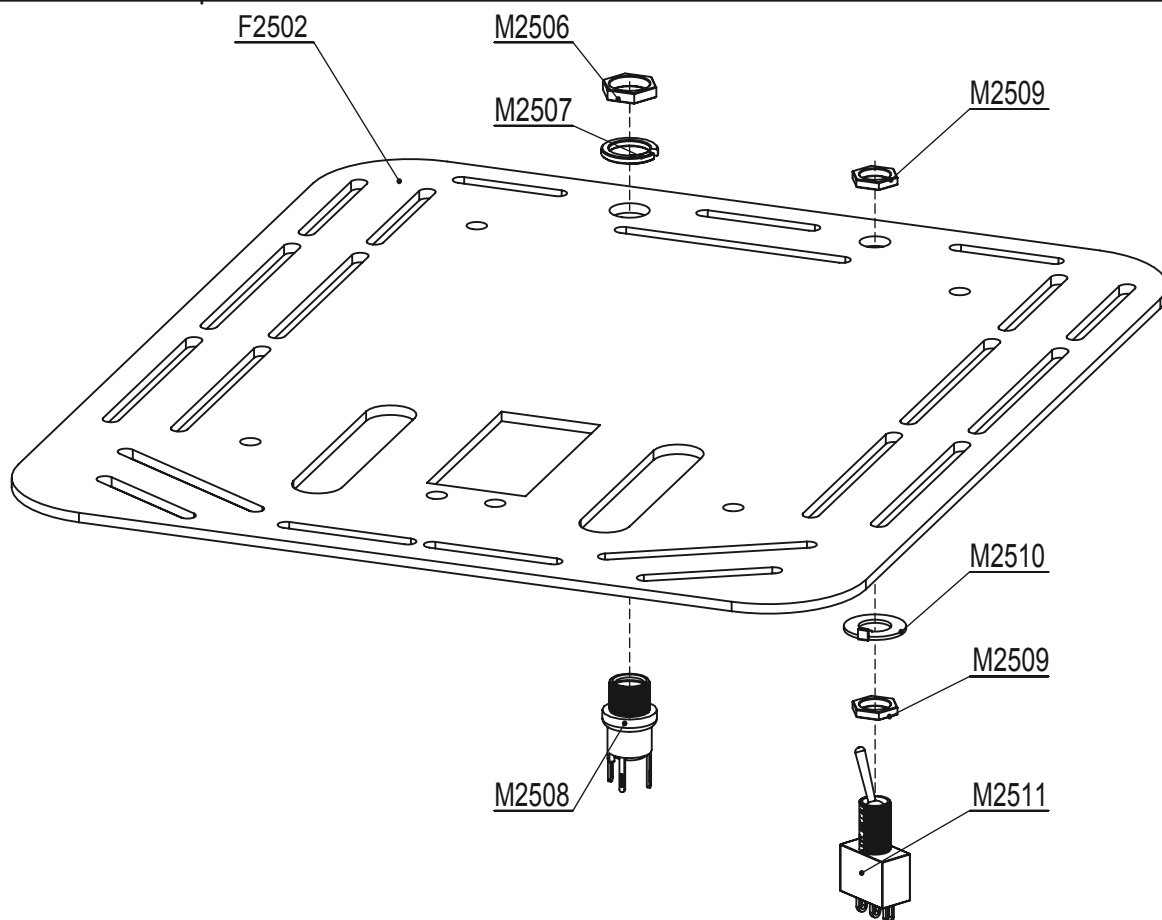
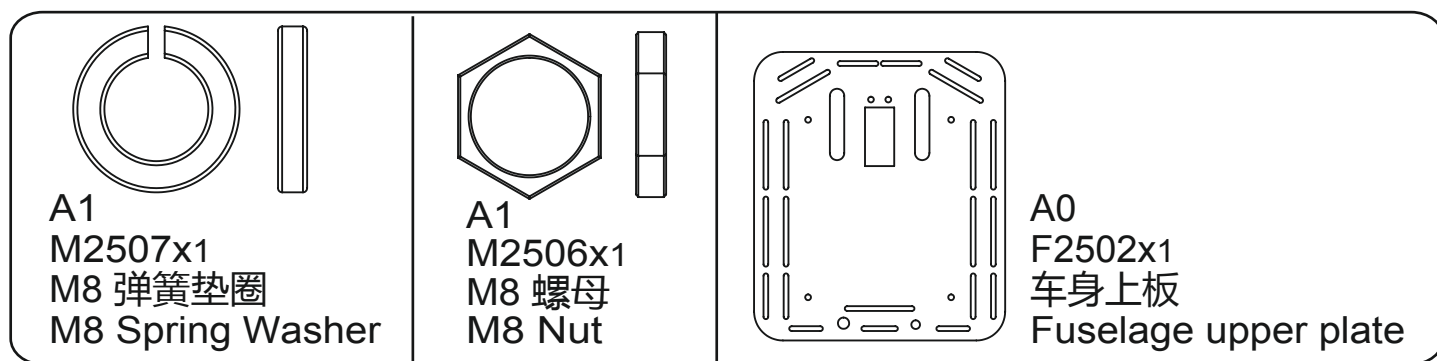

# 红外传感器支架安装 IR Sensor Brackets Assembly

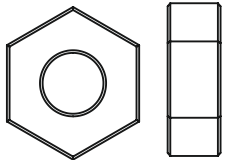
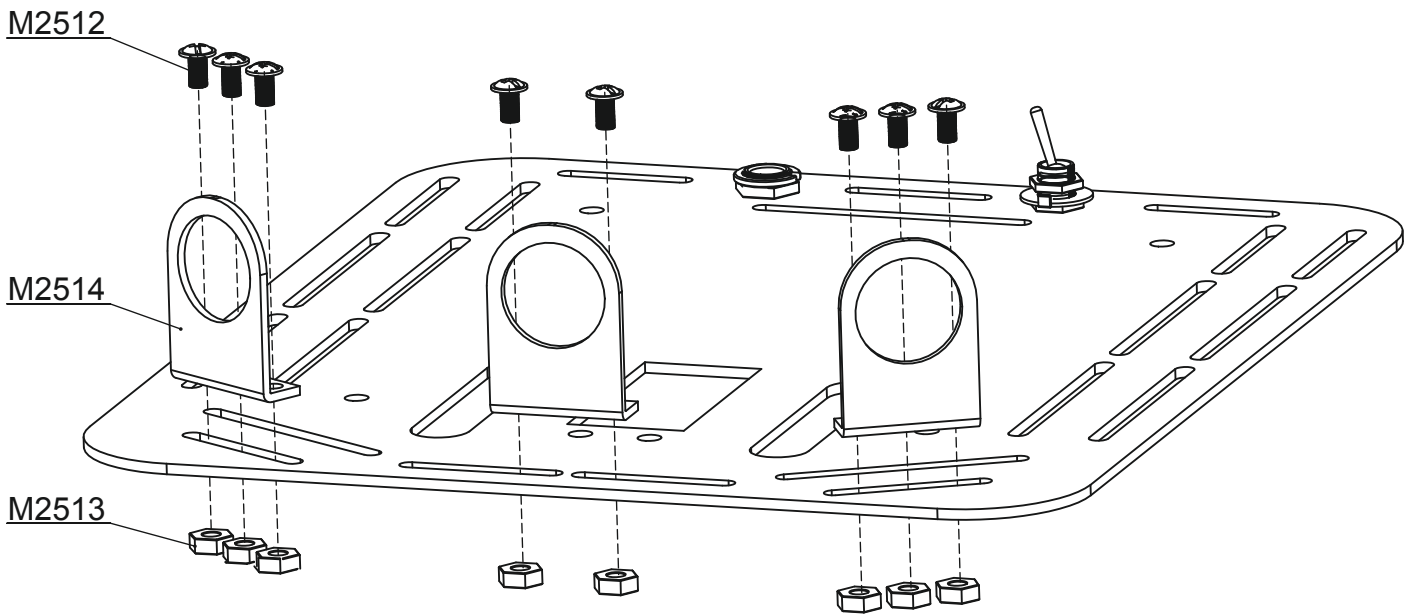

A1  
M2513x8  
M3 螺母  
M3 Nut

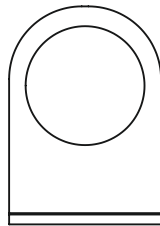

A1  
M2514x3  
红外传感器支架  
IR Sensor Mounting Bracket

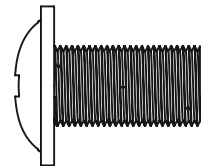

A1  
M2512x8  
M3x6mm 平圆头十字带垫螺丝  
Philips Flange Screw (M3x6mm)

# 车身上板安装 Upper Deck Assembly

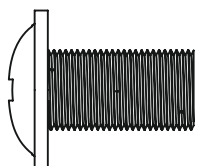
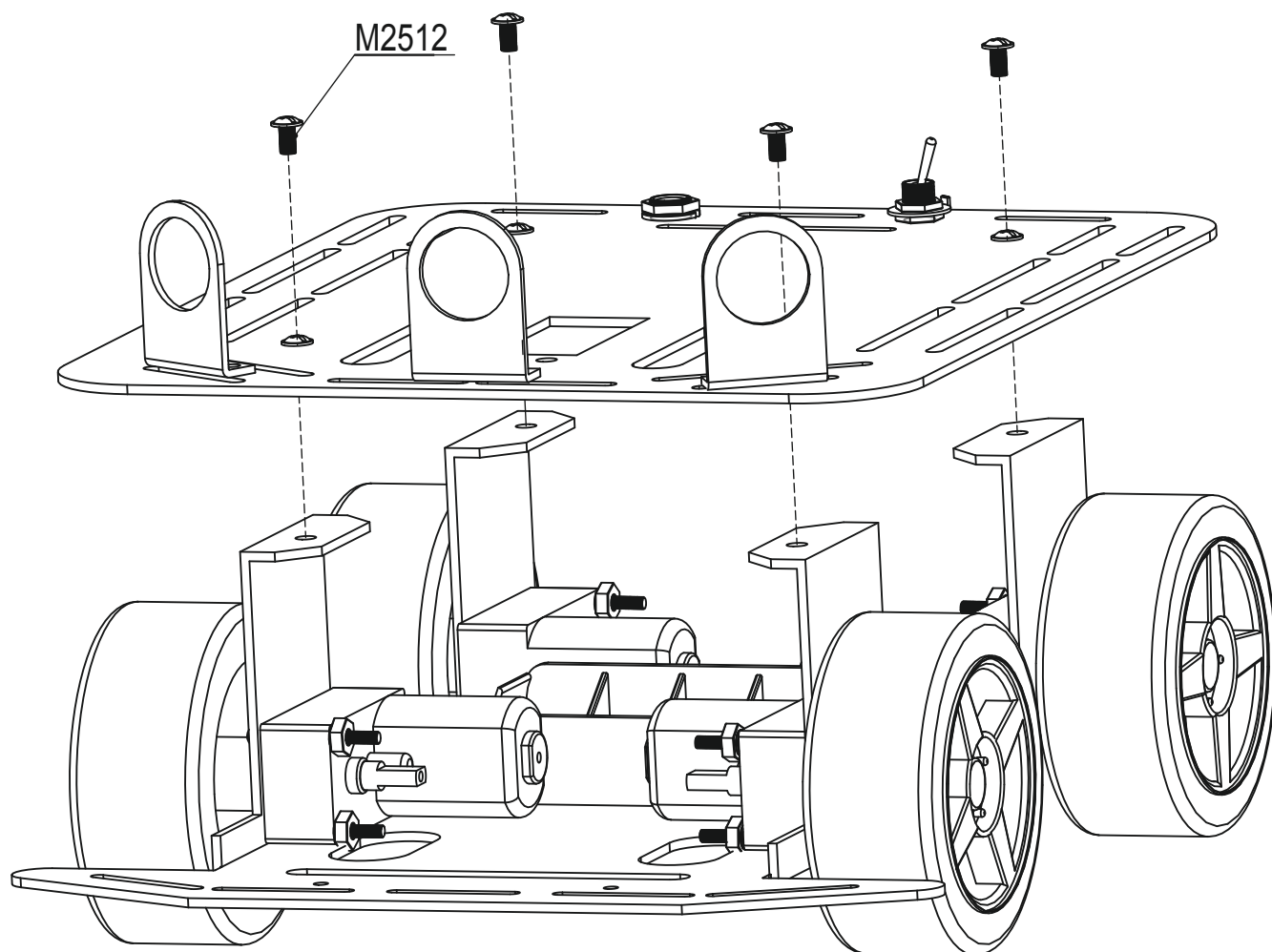

A1

M2512x4

M3x6mm 平圆头十字带垫螺丝

Philips Flange Screw (M3x6mm)

# 编码盘安装 Encoder Wheel Assembly

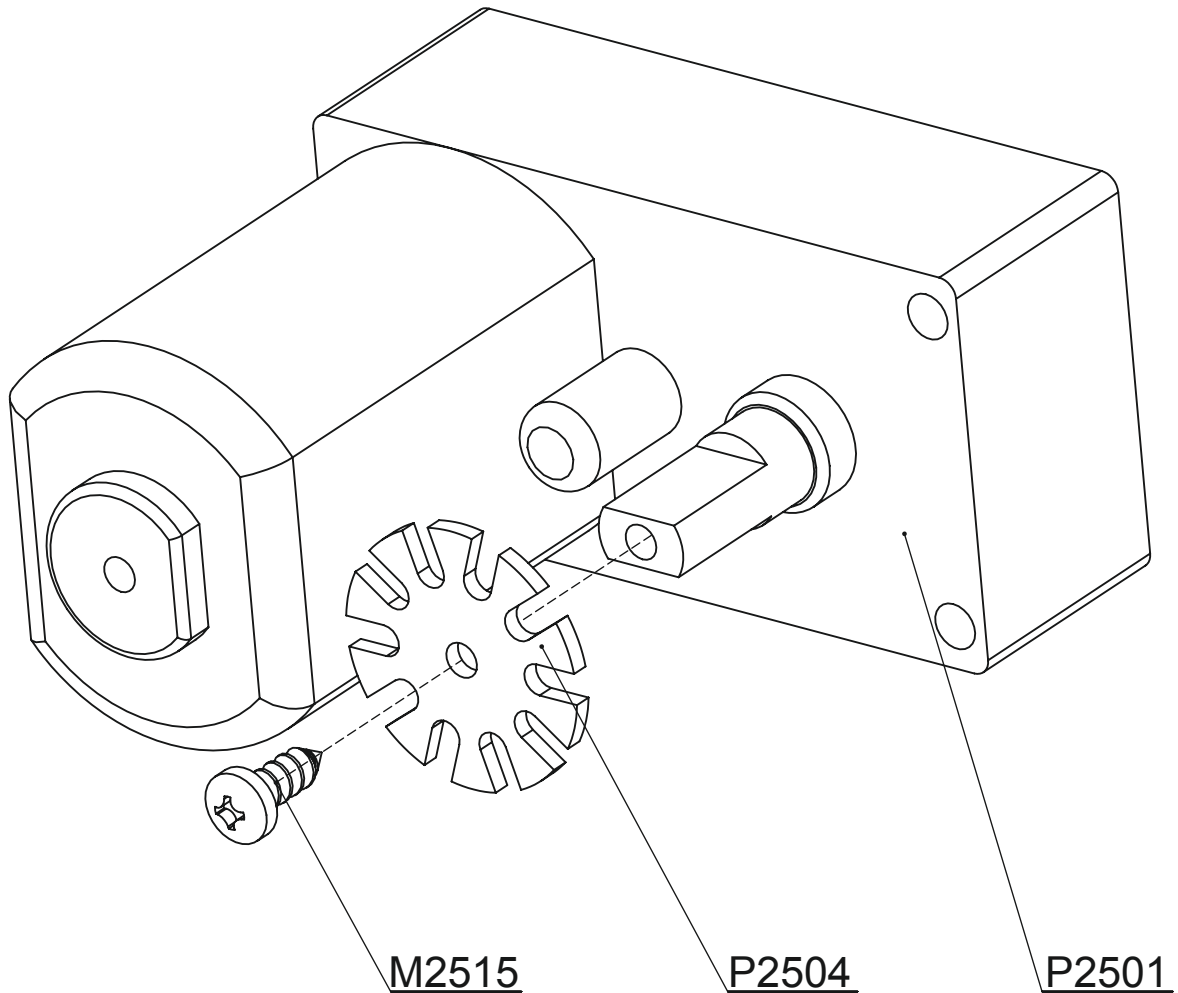

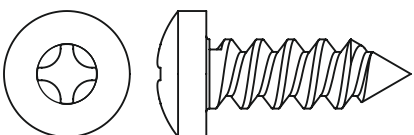
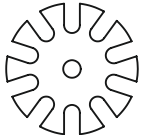
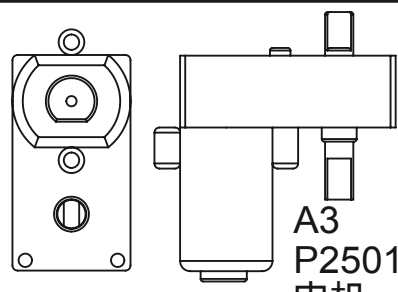
 <p>A2 M2515x1 M2.5mm 自攻螺丝 M2.5mm Self-tapping Screw</p>	 <p>A2 P2504x1 编码盘 Encoder Wheel</p>	 <p>A3 P2501x1 电机 Motor</p>
---	---	--

# 编码器安装 Encoder Sensor Assembly

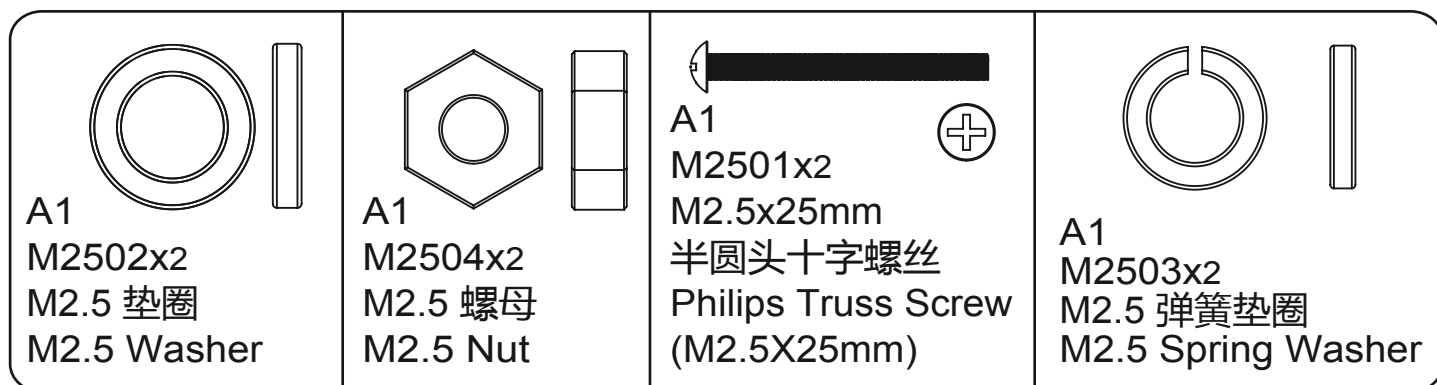
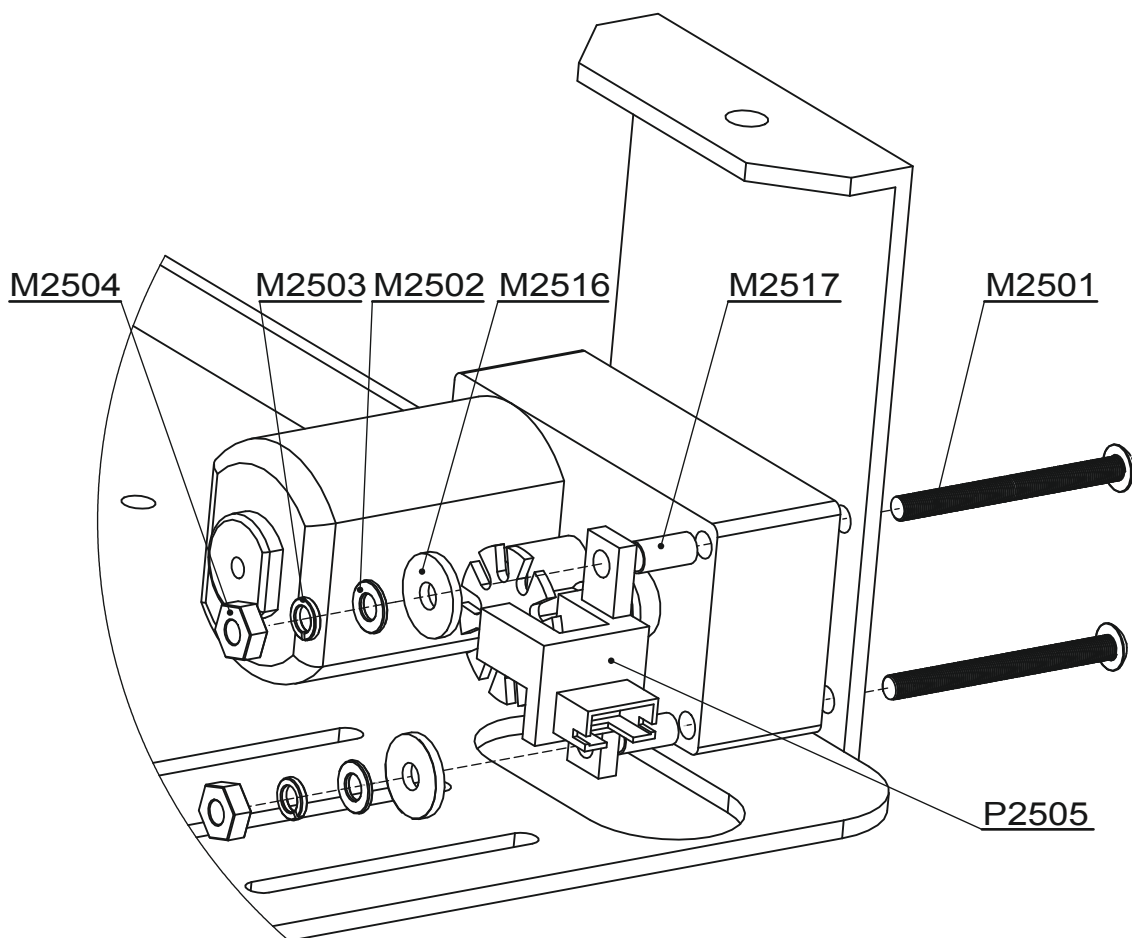
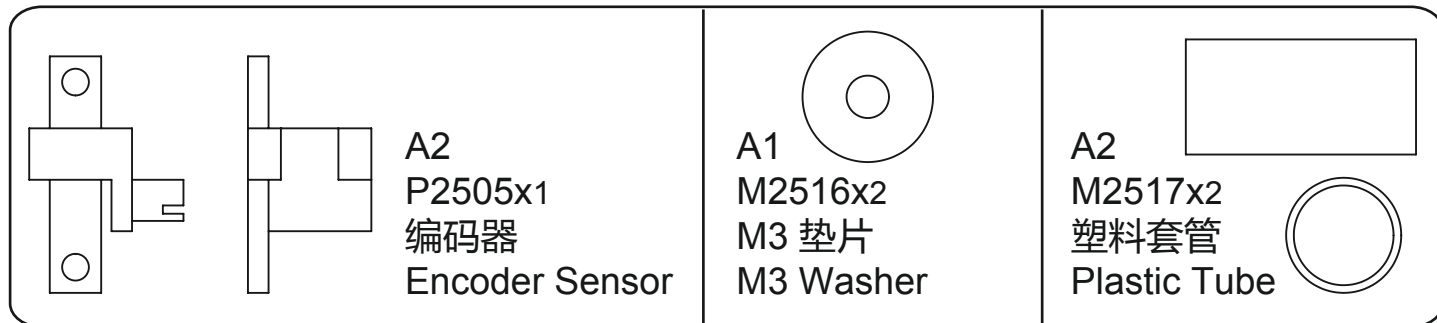

# 零部件清单(A) Parts List(A)

编号 Product NO.	盒编号 BOX	袋编号 Packet	名称 Name	数量 Amount	备注 Remark
F2501	A0		车身下板 Fuselage Base Plate	1	
F2502	A0		车身上板 Fuselage upper plate	1	
M2501	A1		M2.5X25mm 半圆头十字螺丝 Philips Truss Screw(M2.5X25mm)	8	
M2502	A1		M2.5 垫圈 M2.5 Washer	8	
M2503	A1		M2.5 弹簧垫圈 M2.5 Spring Washer	8	
M2504	A1		M2.5 螺母 M2.5 Nut	8	
M2505	A1		M3X4mm 沉头十字螺丝 Philips Contersunk Screw(M3X4mm)	2	
M2506	A1		M8 螺母 M8 Nut	1	
M2507	A1		M8 弹簧垫圈 M8 Spring Washer	1	
M2508	A1		电源插口 Power Jack	1	
M2509	A1		M6 螺母 M6 Nut	1	

# 零部件清单(B) Parts List(B)

编号 Product NO.	盒编号 BOX	袋编号 Packet	名称 Name	数量 Amount	备注 Remark
M2510	A1		M6 专用垫片 M6 Special Washer	1	
M2511	A1		电源开关 Power Switch	1	
M2512	A1		M3x6mm 平圆头十字带垫螺丝 Philips Flange Screw (M3x6mm)	12	
M2513	A1		M3 螺母 M3 Nut	8	
M2514	A1		红外传感器支架 IR Sensor Mounting Bracket	3	
P2501	A3		电机 Motor	4	
P2502	A1		电池盒 Battery Holder	1	
P2503	A0		轮子 Wheel	4	

# 零部件清单(C) Parts List(C)

编号 Product NO.	盒编号 BOX	袋编号 Packet	名称 Name	数量 Amount	备注 Remark
M2501	A1		M2.5X25mm 半圆头十字螺丝 Philips Truss Screw(M2.5X25mm)	4	
M2502	A1		M2.5垫圈 M2.5Washer	4	
M2503	A1		M2.5 弹簧垫圈 M2.5 Spring Washer	4	
M2504	A1		M2.5 螺母 M2.5 Nut	4	
M2515	A2		M2.5 自攻螺丝 M2.5 Self-tapping Scre	2	
M2516	A1		M3 垫片 M3 Washer	4	
M2517	A2		塑料套管 Plastic Tube	4	
P2504	A2		编码盘 Encoder Wheel	2	
P2505	A2		编码器 Encoder Sensor	2	



设计与监制  
Design&Executive

北京龙凡汇众机器人科技有限公司  
Beijing LongFanHuiZhong Robotics  
Technology CO.,LTD

服务支持  
Service

Service@DFRobot.com

网站  
Website

www.DFRobot.com.cn  
www.DFRobot.com

本说明书最终解释权归DFRobot所有

DFRobot has the final authority of interpretation on this manual.

**DFRobot**