

KIT33883FRDMEVMUG

KIT33883FRDMEVM evaluation board

Rev. 1.0 — 9 May 2017

User guide

1 KIT33883FRDM-EVM evaluation board



Figure 1. KIT33883FRDM-EVM with FRDM-KL25Z Freedom Development Platform



2 Important notice

NXP provides the enclosed product(s) under the following conditions:

This evaluation kit is intended for use of ENGINEERING DEVELOPMENT OR EVALUATION PURPOSES ONLY. It is provided as a sample IC pre-soldered to a printed circuit board to make it easier to access inputs, outputs, and supply terminals. This evaluation board may be used with any development system or other source of I/O signals by simply connecting it to the host MCU or computer board via off-the-shelf cables. This evaluation board is not a Reference Design and is not intended to represent a final design recommendation for any particular application. Final device in an application will be heavily dependent on proper printed circuit board layout and heat sinking design as well as attention to supply filtering, transient suppression, and I/O signal quality.

The goods provided may not be complete in terms of required design, marketing, and or manufacturing related protective considerations, including product safety measures typically found in the end product incorporating the goods. Due to the open construction of the product, it is the user's responsibility to take any and all appropriate precautions with regard to electrostatic discharge. In order to minimize risks associated with the customers applications, adequate design and operating safeguards must be provided by the customer to minimize inherent or procedural hazards. For any safety concerns, contact NXP sales and technical support services.

Should this evaluation kit not meet the specifications indicated in the kit, it may be returned within 30 days from the date of delivery and will be replaced by a new kit.

NXP reserves the right to make changes without further notice to any products herein. NXP makes no warranty, representation or guarantee regarding the suitability of its products for any particular purpose, nor does NXP assume any liability arising out of the application or use of any product or circuit, and specifically disclaims any and all liability, including without limitation consequential or incidental damages. "Typical" parameters can and do vary in different applications and actual performance may vary over time. All operating parameters, including "Typical", must be validated for each customer application by customer's technical experts.

NXP does not convey any license under its patent rights nor the rights of others. NXP products are not designed, intended, or authorized for use as components in systems intended for surgical implant into the body, or other applications intended to support or sustain life, or for any other application in which the failure of the NXP product could create a situation where personal injury or death may occur.

Should the Buyer purchase or use NXP products for any such unintended or unauthorized application, the Buyer shall indemnify and hold NXP and its officers, employees, subsidiaries, affiliates, and distributors harmless against all claims, costs, damages, and expenses, and reasonable attorney fees arising out of, directly or indirectly, any claim of personal injury or death associated with such unintended or unauthorized use, even if such claim alleges NXP was negligent regarding the design or manufacture of the part.

NXP and the NXP logo are trademarks of NXP B.V. All other product or service names are the property of their respective owners. © NXP B.V. 2017.

3 Getting started

3.1 Kit contents and packing list

The KIT33883FRDM-EVM contents include:

- Assembled and tested evaluation board/module with MC33883 in an antistatic bag
- FRDM-KL25Z board
- Warranty card

3.2 Jump start

The analog product development boards from NXP help the evaluation of NXP products. These tools support analog mixed signal and power solutions, including monolithic ICs using proven high-volume SMARTMOS mixed signal technology, and system-in-package devices utilizing power, SMARTMOS and MCU dies. NXP products enable longer battery life, smaller form factor, component count reduction, ease of design, lower system cost and improved performance in powering state-of-the-art systems.

- Go to the tool summary page: www.nxp.com/KIT33883FRDMEVM
- Locate your kit
- Review your tool summary page
- Look for

Jump Start Your Design

- Download documents, software and other information

Once the files are downloaded, review the user guide in the bundle. The user guide includes setup instructions, BOM and schematics. Jump start bundles are available on each tool summary page with the most relevant and current information. The information includes everything needed for design.

3.3 Required equipment

To use this kit, you need:

- DC Power supply (5.5 V to 55 V, up to 20 A current handling capability, depending on motor requirements)
- USB Mini-B to Standard A cable
- Typical loads (brushed DC motor, power resistors or inductive load)
- Function generator (required if FRDM-KL25Z not used)
- FRDM-KL25Z Freedom Development Platform (included in KIT)
- 3/16" blade screwdriver

3.4 System requirements

To use this kit, you need:

- USB-enabled PC with Windows® XP or higher

4 Getting to know the hardware

4.1 Board overview

The KIT33883FRDM-EVM Evaluation Board (EVB) is an easy-to-use circuit board that allows the user to exercise all the functions of the MC33883 H-Bridge device. The EVB parallel input can be easily controlled through lab equipment, any MCU with GPIOs or FRDM-KL25Z board connected to a PC's USB port.

4.2 Board features

The KIT33883FRDM-EVM evaluation board is able to easily evaluate and test the main component, the MC33883. The main features of the board are as follows:

- Compatible with Freedom Development Platform Accessory Boards
- Built-in reverse battery protection
- Screw terminals to provide easy connection of power and loads
- Test points to allow probing of signals
- LEDs to indicate status of the supply
- Low ESR capacitor to reduce ripple in the power supply

4.3 Block diagram

The hardware basic block diagram of KIT33883FRDM-EVM is shown in [Figure 2](#).

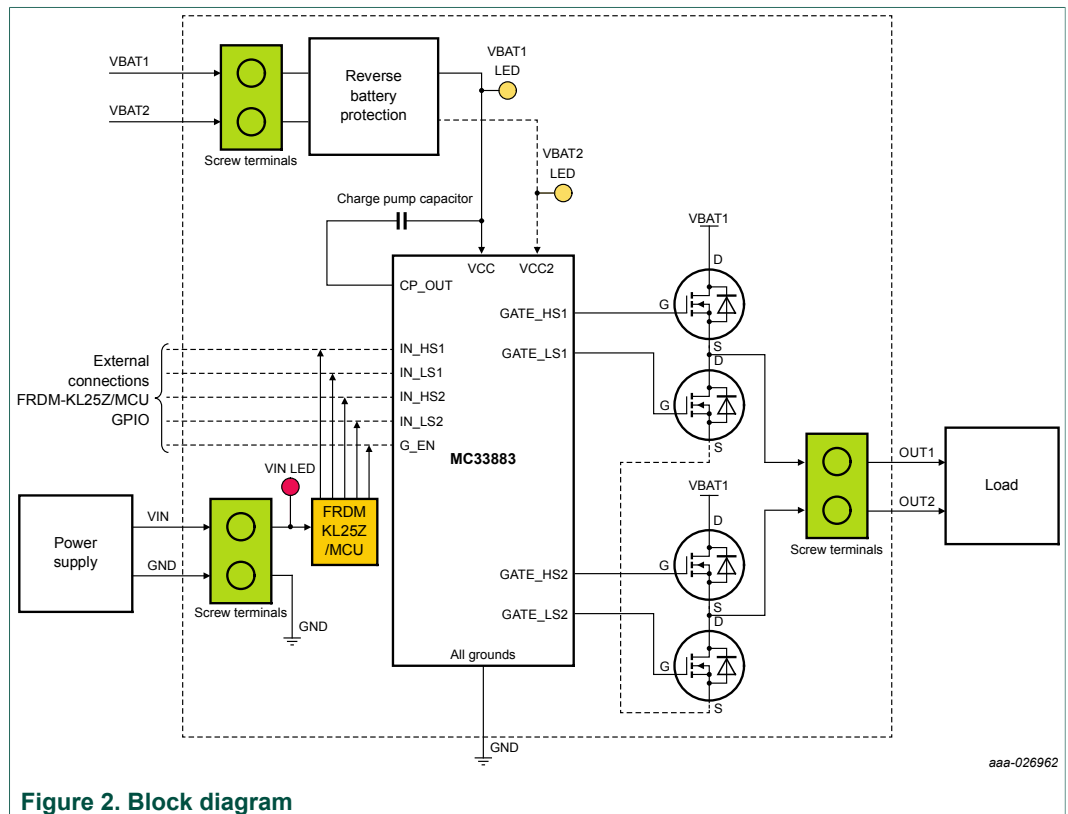

Figure 2. Block diagram

aaa-026962

4.4 Device features

This evaluation board features the following NXP product:

Table 1. Device features

| Evaluation board | Device | Device features |
|------------------|---------|---|
| KIT33883FRDM-EVM | MC33883 | <p>The 33883 is an H-Bridge gate driver with integrated charge pump and independent high and low side gate drive channels. The gate driver channels are independently controlled by four separate input pins, allowing the device to be optionally configured as two independent high side gate drivers and two independent low side gate drivers. The low side channels are referenced to ground. The high side channels are floating.</p> <ul style="list-style-type: none"> • Gate driver outputs can source and sink up to 1.0 A peak current pulses, permitting large gate-charge MOSFETs to be driven and/or high pulse-width modulation (PWM) frequencies to be utilized. • A linear regulator is incorporated, providing a 15 V typical gate supply to the low side gate drivers • This device powered by SMARTMOS technology • V_{CC} operating voltage range from 5.5 V up to 55 V • V_{CC2} operating voltage range from 5.5 V up to 28 V • CMOS / LSTTL compatible I / O • 1.0 A peak gate driver current • Built-in high-side charge pump • Undervoltage lockout (UVLO) • Overvoltage lockout (OVLO) • Global enable with <10uA Sleep mode • Supports PWM up to 100 kHz |

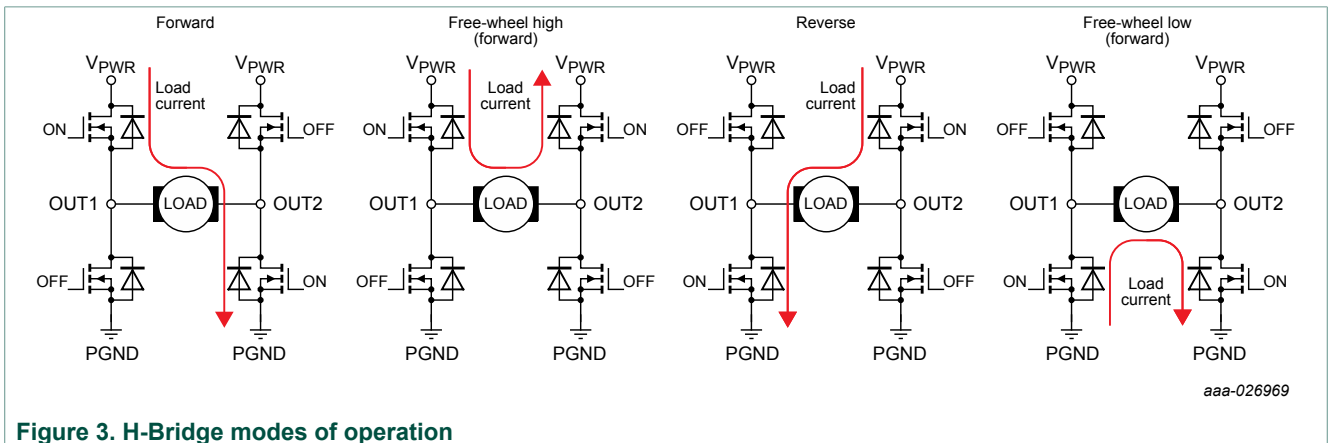
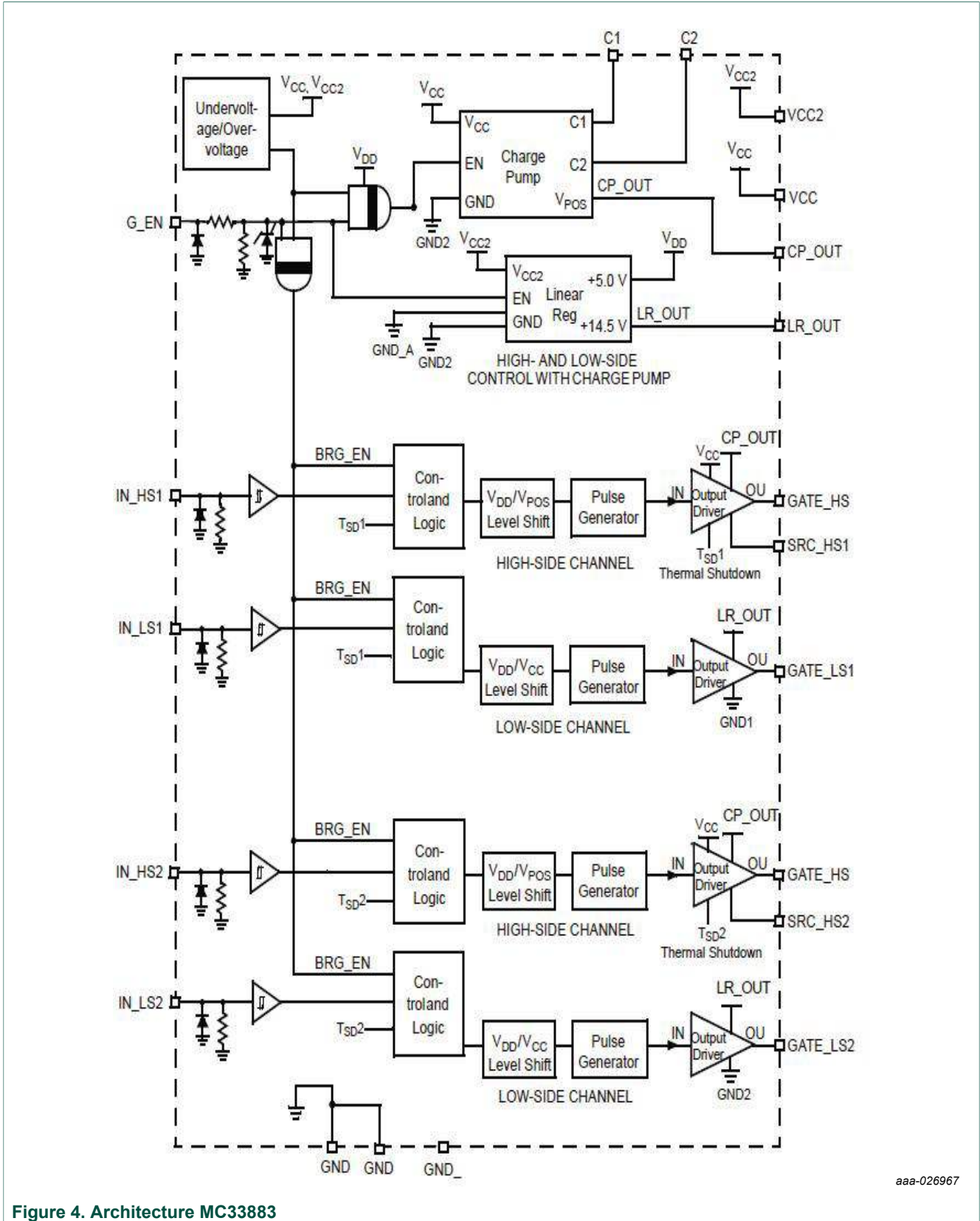

Figure 3. H-Bridge modes of operation



aaa-026967

Figure 4. Architecture MC33883

4.5 Board description

Figure 5 describes the main components of the KIT33883FRDM-EVM.

Table 2. Board description

| Name | Description |
|----------------------------|--|
| MC33883 | H-Bridge gate driver IC in a robust 20 pin SOIC package |
| Jumpers | Jumpers for configuring the board for different modes of operation |
| Reverse battery protection | MOSFET for protecting MC33883 in reverse battery condition |
| Power and ground inputs | Power supply terminal to connect the battery/power supplies with the board |
| Test points | Test points to probe different signals |
| FRDM-KL25Z module | NXP Freedom development platform |
| Output terminal | Output connector to connect a load to the MC33883 controlled output |

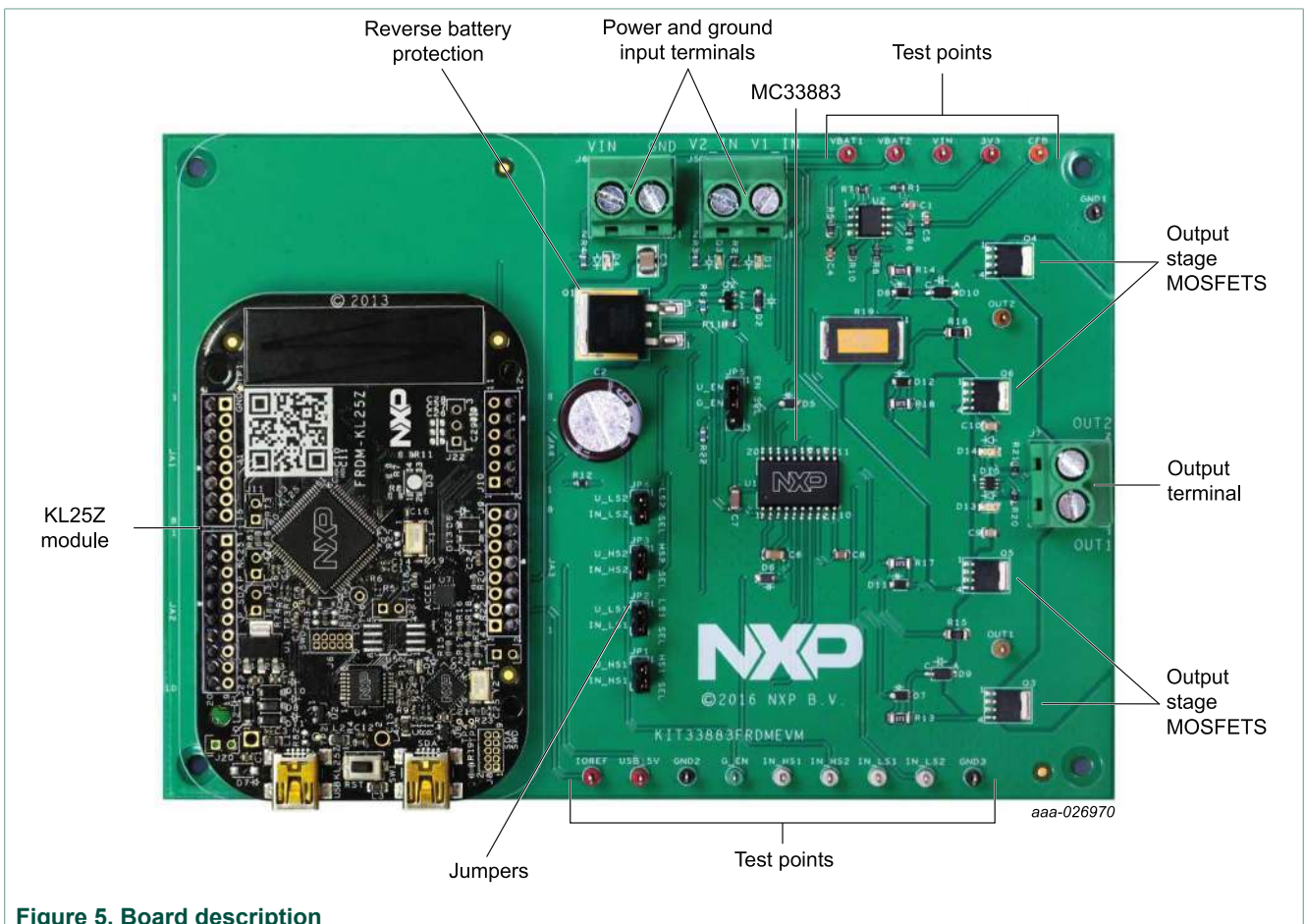

Figure 5. Board description

4.6 LED display

The following table describes LEDs provided as visual output devices for the KIT33883EVM evaluation board:

Table 3. LED Display

| LED ID | Description |
|-------------|--|
| V1_IN/VBAT1 | Yellow LED, indicates when main/battery supply is connected and powered on |
| V2_IN/VBAT2 | Yellow LED, indicates when battery supply is connected and on |
| VIN | Red LED, indicates when +5.0V supply is connected and powered on |
| FORWARD | Green LED, indicates when output is driving in the forward direction |
| REVERSE | Red LED, indicates when output is driving in the reverse direction |



Figure 6. Board description

4.7 Test point definitions

The following test-points provide access to signals on the FRDM-HB2001-EVM.

Table 4. Test point definitions

| Test Point Name | Signal name | Description |
|-----------------|-------------|---|
| VBAT1 | VBAT1 | Supply voltage for part VCC and MOSFETs |
| VBAT2 | VBAT2 | Supply voltage for VCC2 |
| VIN | VIN | Supply voltage for FRDM-KL25Z module (required only for operation without USB connection) |
| USB_5V | USB_5V | 5 V Supply voltage from USB cable |
| 3V3 | 3V3 | 3.3 V Supply voltage from FRDM-KL25Z |
| IOREF | IOREF | 3.3 V supply for G_EN pull-up |

| Test Point Name | Signal name | Description |
|-----------------|-------------|--|
| CFB | CFB | Current sense output for real time load current monitoring |
| G_EN | G_EN | Logic input Enable control of device |
| IN_HS1 | IN_HS1 | Logic input control of high-side 1 gate |
| IN_LS1 | IN_LS1 | Logic input control of low-side 1 gate |
| IN_HS2 | IN_HS2 | Logic input control of high-side 2 gate |
| IN_LS2 | IN_LS2 | Logic input control of low-side 2 gate |
| OUT1 | OUT1 | Output 1 of H-Bridge |
| OUT2 | OUT2 | Output 2 of H-Bridge |
| GND1 | GND | Ground signal |
| GND2 | GND | Ground signal |
| GND3 | GND | Ground signal |

4.8 Input signal definitions

The KIT33883FRDM-EVM board has following input signals which are used to control the outputs or functions inside the circuit.

Table 5. Input signal definitions

| Input name | Description |
|------------|--|
| IN_HS1 | Logic input control of high-side 1 gate, such as IN_HS1 logic HIGH = GATE_HS1 HIGH) |
| IN_LS1 | Logic input control of low-side 1 gate, such as IN_LS1 logic HIGH = GATE_LS1 HIGH) |
| IN_LS2 | Logic input control of low-side 2 gate, such as IN_LS2 logic HIGH = GATE_LS2 HIGH) |
| IN_HS2 | Logic input control of high-side 2 gate, such as IN_HS2 logic HIGH = GATE_HS2 HIGH) |
| G_EN | Logic input Enable control of device, such as G_EN logic HIGH = Full Operation, G_EN logic LOW = Sleep Mode) |

4.9 Output signal definitions

The KIT33883FRDM-EVM board has the following output signals that are used to drive a load, such as a brushed DC motor. The board provides an analog output for real-time load-current monitoring. This signal allows closed-loop control of the load.

Table 6. Output signal definitions

| Output name | Description |
|-------------|--|
| OUT1 | Output 1 of H-Bridge |
| OUT2 | Output 2 of H-Bridge |
| CFB | Current sense output for real-time load-current monitoring |

4.10 Screw terminal connections

The KIT33883FRDM-EVM board features screw terminal connections to allow easy access to device signals and supply rails.

Table 7. Screw terminal definitions

| Name | Description |
|------|--|
| J5 | Power supply connector for MC33883 and MOSFETs |
| J6 | Power supply connector for FRDM-KL25Z platform |
| J7 | Output connector to connect load |

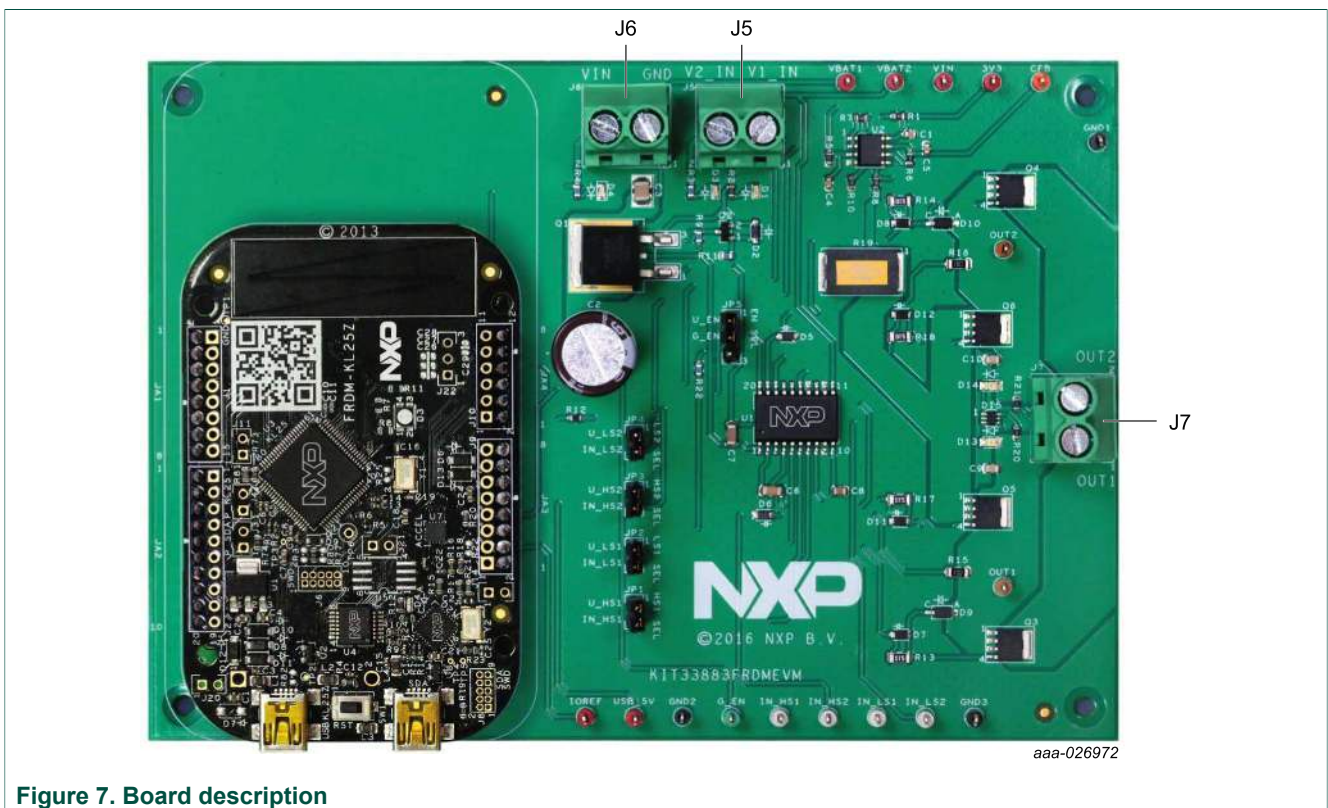

Figure 7. Board description

4.11 Jumpers

The board features jumper connections as shown in [Table 8](#).

Table 8. Jumpers

| Name | Signal | Position | Connection |
|------|--------|----------|--|
| JP1 | HS1 | 1-2 / 2 | HS1 signal from micro controller / External signal on pin 2 |
| JP2 | LS1 | 1-2 / 2 | LS1 signal from micro controller / External signal on pin 2 |
| JP3 | HS2 | 1-2 / 2 | HS2 signal from micro controller / External signal on pin 2 |
| JP4 | LS2 | 1-2 / 2 | LS2 signal from micro controller / External signal on pin 2 |
| JP5 | EN | 1-2 / 2 | Enable signal from micro controller / External signal on pin 2 |

KIT33883FRDM-EVM gives the user freedom to operate the part using the FRDM-KL25Z board with GUI, any MCU with GPIO and ADC and simple lab equipment. A GUI and an MCU program, which works with the FRDM-KL25Z (shipped with the EVM), are available online at the evaluation board tool summary page at www.nxp.com/KIT33883FRDMEVM.

Moreover, KIT33883FRDM-EVM is compatible with any Arduino platform board. Nonetheless, the user will need to write MCU code to make it work with any board other than the FRDM-KL25Z.

5 FRDM-KL25Z Freedom Development Platform

The NXP Freedom development platform is a set of software and hardware tools for evaluation and development. It is ideal for rapid prototyping of microcontroller-based applications. The NXP Freedom KL25Z hardware, FRDM-KL25Z, is a simple, yet sophisticated design featuring a Kinetis L Series microcontroller, the industry's first microcontroller built on the ARM® Cortex™-M0+ core.

5.1 Connecting a FRDM-KL25Z to the board

The KIT33883FRDM-EVM kit may be used with many of the Freedom platform evaluation boards featuring Kinetis processors. The FRDM-KL25Z evaluation board has been chosen specifically to work with the KIT33883FRDM-EVM kit because of its low cost and features. The FRDM-KL25Z board makes use of the USB, built in LEDs, and I/O ports available with NXP's Kinetis KL2x family of microcontrollers. The main functions provided by the FRDM-KL25Z are to allow control of a DC brushed motor using a PC computer over USB, and to drive the necessary inputs on the KIT33883FRDM-EVM evaluation kit to operate the motor via GPIOs.

The KIT33883FRDM-EVM is connected to the FRDM-KL25Z using four single row headers. The connections are as follows in [Table 9](#)

Table 9. KIT33883FRDM-EVM to FRDM-KL25Z connections

| KIT33883FRDM-EVM | | | | FRDM-KL25Z | | |
|------------------|-----|--------|---|------------|-----|-----------|
| Header | Pin | Name | Description | Header | Pin | Name |
| JA1 | 1 | N/C | No connection | J1 | — | — |
| JA1 | 2 | N/C | No connection | J1 | — | — |
| JA1 | 3 | N/C | No connection | J1 | — | — |
| JA1 | 4 | U_HS1 | IN_HS1 signal from MCU | J1 | 8 | PTA12 |
| JA1 | 5 | N/C | No connection | J1 | — | — |
| JA1 | 6 | U_LS1 | IN_LS1 signal from MCU | J1 | 12 | PTA5 |
| JA1 | 7 | U_HS2 | IN_HS2 signal from MCU | J1 | 14 | PTC8 |
| JA1 | 8 | N/C | No connection | J1 | — | — |
| JA2 | 1 | N/C | No connection | J2 | — | — |
| JA2 | 2 | U_LS2 | IN_LS2 signal from MCU | J2 | 4 | PTD5 |
| JA2 | 3 | N/C | No connection | J2 | — | — |
| JA2 | 4 | N/C | No connection | J2 | — | — |
| JA2 | 5 | N/C | No connection | J2 | — | — |
| JA2 | 6 | N/C | No connection | J2 | — | — |
| JA2 | 7 | GND | Ground connection | J2 | 14 | GND |
| JA2 | 8 | N/C | No connection | J2 | — | — |
| JA2 | 9 | N/C | No connection | J2 | — | — |
| JA2 | 10 | N/C | No connection | J2 | — | — |
| JA3 | 1 | N/C | No connection | J9 | — | — |
| JA3 | 2 | IOREF | 3.3V supply for G_EN pull-up | J9 | 4 | P3V3 |
| JA3 | 3 | N/C | No connection | J9 | — | — |
| JA3 | 4 | 3V3 | 3.3V output from FRDM-KL25Z | J9 | 8 | P3V3 |
| JA3 | 5 | USB_5V | 5V supply from USB connection | J9 | 10 | P5V_USB |
| JA3 | 6 | GND | Ground connection | J9 | 12 | GND |
| JA3 | 7 | GND | Ground connection | J9 | — | — |
| JA3 | 8 | VIN | VIN supply signal | J9 | 16 | P5-9V_VIN |
| JA4 | 1 | U_CFB | Current feedback from current sense circuit | J10 | 2 | PTB0 |
| JA4 | 2 | N/C | No connection | J10 | — | — |
| JA4 | 3 | N/C | No connection | J10 | — | — |
| JA4 | 4 | U_EN | Enable signal from MCU | J10 | 8 | PTB3 |
| JA4 | 5 | N/C | No connection | J10 | — | — |
| JA4 | 6 | N/C | No connection | J10 | — | — |

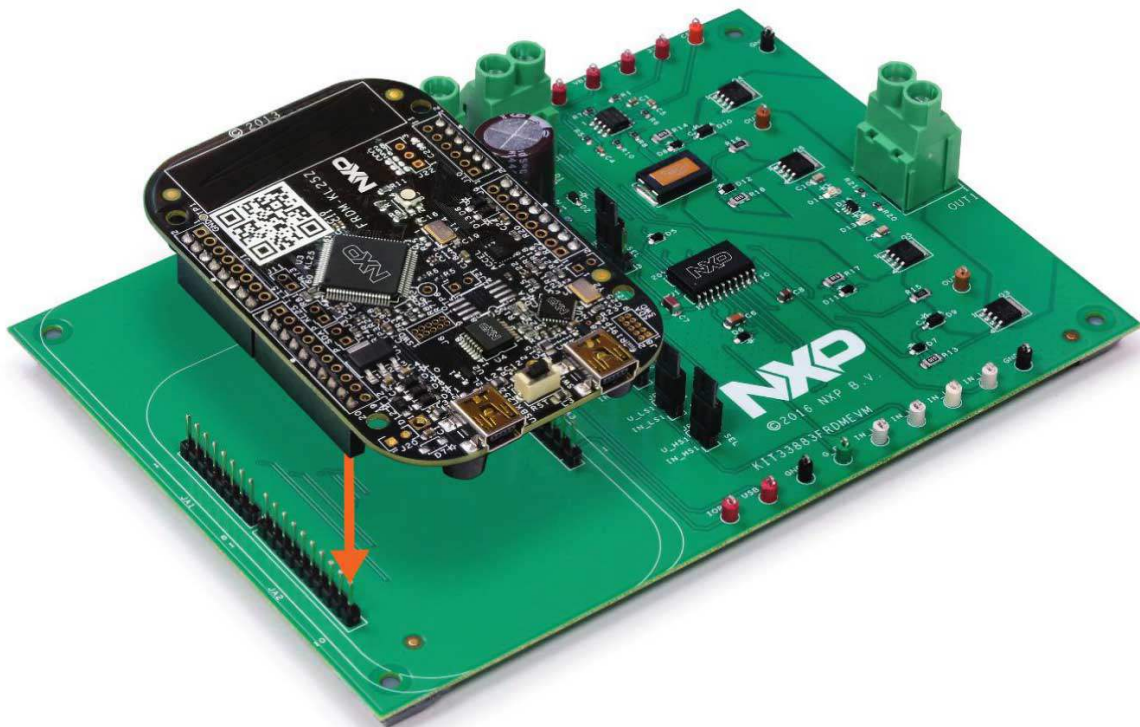

aaa-026973

Figure 8. Board description

6 Setting up the hardware and software

To configure the evaluation board for use with the FRDM KL25Z and the Graphical User Interface (GUI) you must:

- Connect the hardware
- Download the mbed firmware to the FRDM-KL25Z board
- Download the MC33883 microcode to the FRDM-KL25Z board
- Install the Graphical User Interface MC33883 Evaluation Board GUI for KIT33883FRDM-EVM.

6.1 Installing the Motor Control GUI on your computer

The Graphical User Interface (GUI) provides a PC-based interface allowing you to easily exercise KIT33883FRDM-EVM functions to control a DC Brushed Motor. The GUI runs on any Windows 7 or greater operating system.

To install the software:

1. Go to the evaluation board tool summary page at www.nxp.com/KIT33883FRDMEVM.
2. Under Jump Start Your Design, click on the Get Started with the KIT33883FRDM-EVM link.
3. From the list of files that appear, click on the link for the MC33883 GUI software.

The software automatically downloads to your PC and initiates the installation process. An Installation Wizard guides you through the rest of the process.

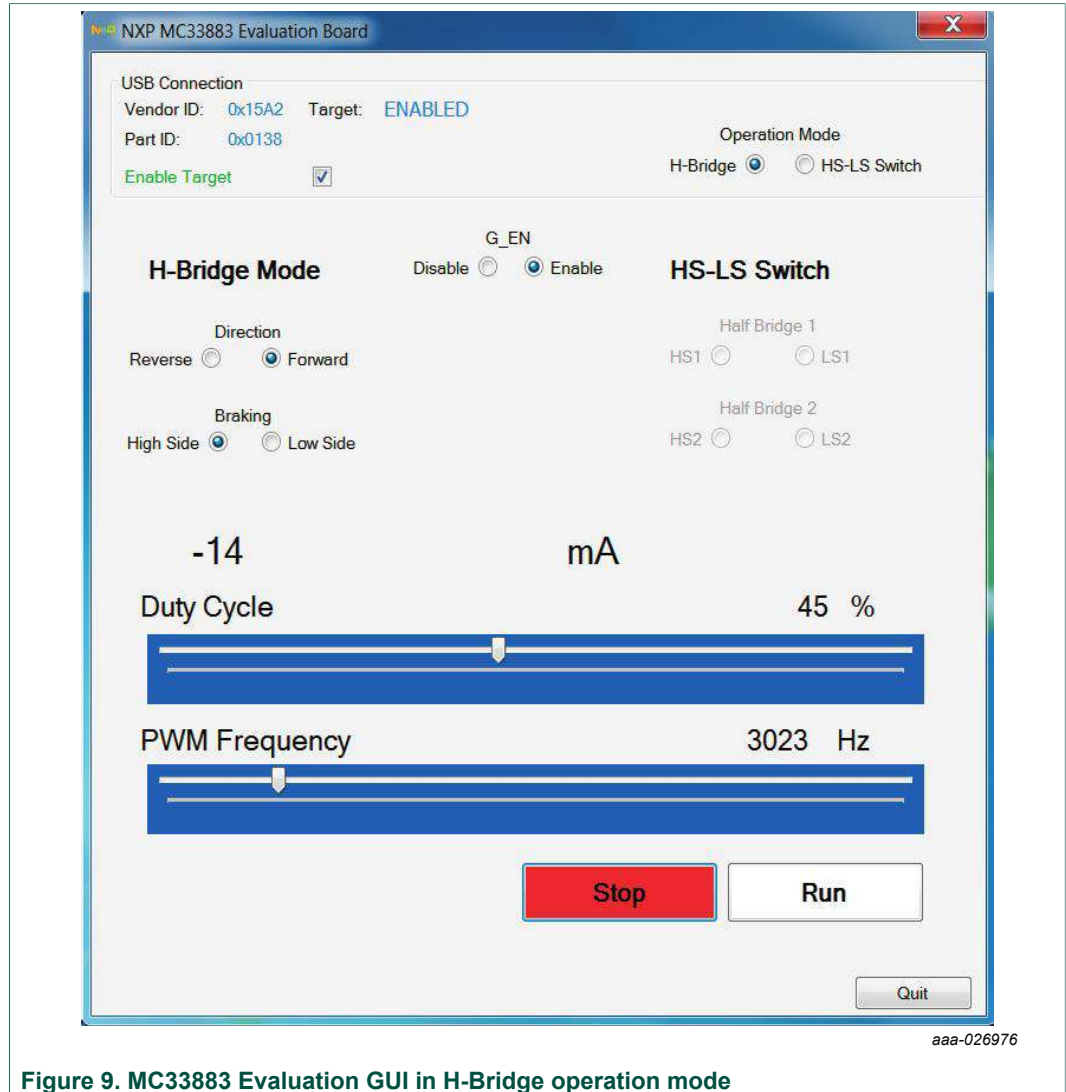

Figure 9. MC33883 Evaluation GUI in H-Bridge operation mode

6.2 Setting up the hardware

The KIT33883FRDM-EVM consists of an H-Bridge, a parallel interface, power conditioning circuitry, and a set of two input select jumpers. All +5.0 V V_{DD} power required by the board is obtained via the parallel interface.

The following operating parameters must be followed when using the KIT33883FRDMEVM, or damage could occur.

- The motor supply voltage ($V1_IN$) must be at least 5.5 V, but must not exceed 55 V.
 - The motor supply voltage ($V2_IN$) must be at least 5.5 V, but not exceed 28 V.
 - The peak operating current of the load must not exceed 20 A.
1. Connect the KIT33883FRDM-EVM to the FRDM-KL25Z.
 2. With the power switched off, attach the DC power supply to the $V1_IN$, $V2_IN$ and GND screw connector terminals on the evaluation board. See note below.

- Attach the motor or load across the OUT1 and OUT2 screw connector terminals on the evaluation board.

Note: For power requirements, less than 28 V V1_IN and V2_IN can be tied together. For power requirements, greater the 28 V supply V1_IN and V2_IN must be connected separately with appropriate voltage and current supply.

The figure below shows the configuration diagram for KIT33883FRDM-EVM.

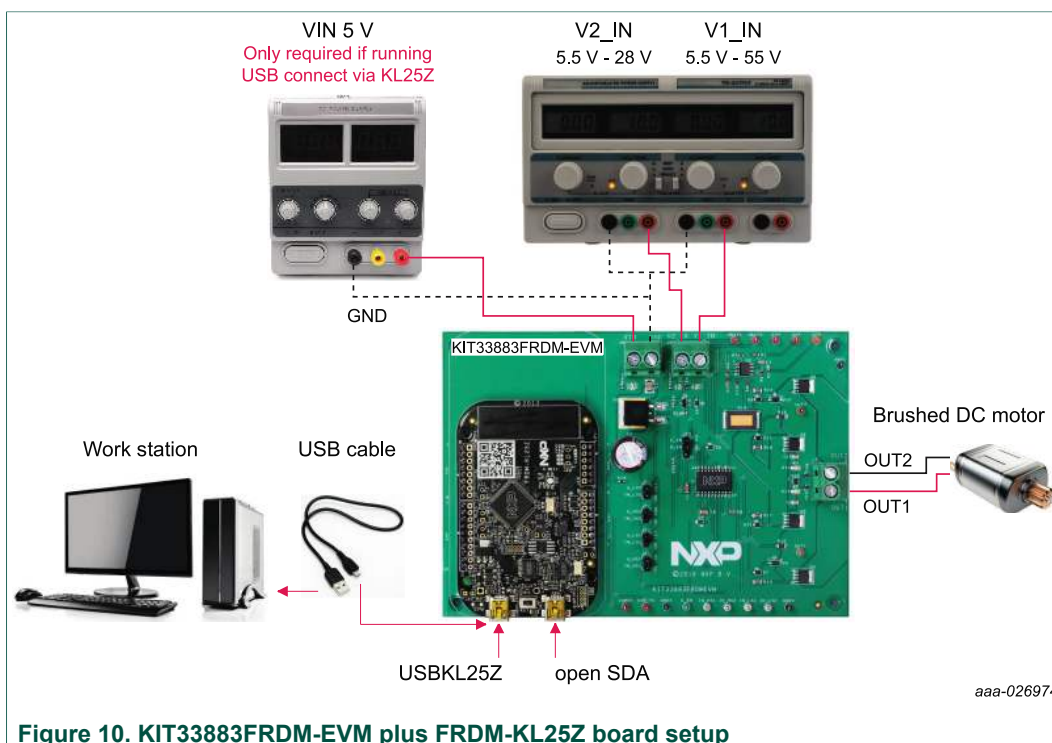

Figure 10. KIT33883FRDM-EVM plus FRDM-KL25Z board setup

6.2.1 Setting up the hardware using the GUI

To start the GUI, do the following:

- Configure the hardware as described in [Section 6.2](#).
- Click on the MC33883 GUI icon to launch the GUI.
- Make sure the GUI recognizes the FRDM-KL25Z. Check the USB connection in the upper left corner of the GUI. The hex Vendor ID value should display as 0x15A2 and the Part ID value should display as 0x138. If these values do not appear, the GUI has failed to establish a connection with the FRDM-KL25Z. You may need to disconnect and reconnect the USB cable to the board's KL25Z USB port. If the connection still fails, press the reset button on the FRDM-KL25Z board.
- Click the Enable Target checkbox on the GUI screen. The Target parameter on the GUI screen should change from DISABLED to ENABLED.
- Set the Operation Mode, G_EN, Direction and Braking as desired (See Section 5.2.6 - Section 5.2.9.) Adjust the PWM Frequency and Duty Cycle to meet your requirements.
- Click Run to run the motor. Notice that some options of the GUI are disabled while the motor is running. To make changes, click Stop, make the desired changes, and then click Run to continue.

7. When finished, Stop, deselect the Enable Target button on the GUI, and click Quit. Turn off DC power supply and remove the USB cable.

The GUI is shown in [Figure 12](#). The hex address numbers at the top are loaded with the vendor ID for Freescale (0x15A2), and the part ID (0x138). The left side panel displays these numbers only if the PC is communicating with the FRDM-KL25Z via the USB interface.

6.3 Downloading software to the FRDM-KL25Z board

6.3.1 Downloading mbed[®] firmware to the FRDM-KL25Z board

You must install mbed[®] firmware on the FRDM-KL25Z board to enable downloading of the MC33883 microcode. The procedure is as follows:

1. Connect the USB cable between your PC and the OpenSDA USB port on the FRDM-KL25Z board.
2. Download the mbed firmware onto the FRDM-KL25Z board. The instructions are on the ARM[®]mbed[™] website at the following url: <https://developer.mbed.org/handbook/Firmware-FRDM-KL25Z>
3. After downloading the mbed firmware, power cycle the board (by disconnecting then reconnecting the USB cable to the OpenSDA port) to initiate the firmware update. When this process completes, a USB drive named “mbed” should appear on your PC.

6.3.2 Downloading the MC33883 microcode to the FRDM-KL25Z board

The MC33883 microcode provides the firmware interface between the MC33883 device, the Freedom platform and the GUI. The procedure is as follows:

1. Connect the USB cable between your PC and the OpenSDA USB port on the FRDM-KL25Z board.
2. Go to www.nxp.com/KIT33883FRDMEVM-Design_Tools_Tab and download the MC33883_KL25Z.bin file to your PC. Copy the file to the MBED drive that appears on your PC after a USB cable is connected to the OpenSDA port. See [Figure 11](#). The source code for MC33883_KL25Z.bin is also available (main.cpp). If modifications are made must be recompiled and can be done by importing into developer.mbed.org, creating an account, and recompiling the project to another .bin file.
3. Remove the USB connector from the FRDM-KL25Z OpenSDA USB port and insert it in the USBKL25Z port. The KL25Z board is now ready for use with the KIT33883FRDM-EVM and the MC33883 Motor Control GUI.

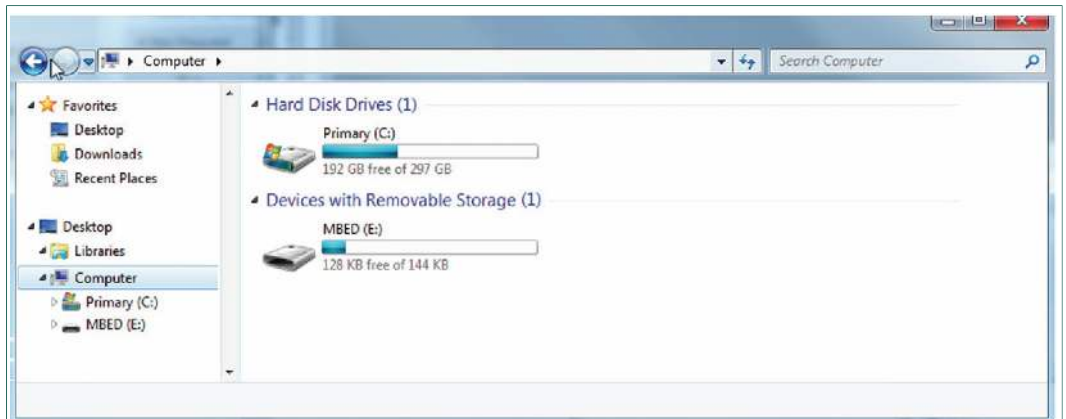

aaa-026975

Figure 11. MBED drive

7 Using the GUI

7.1 H-Bridge mode description

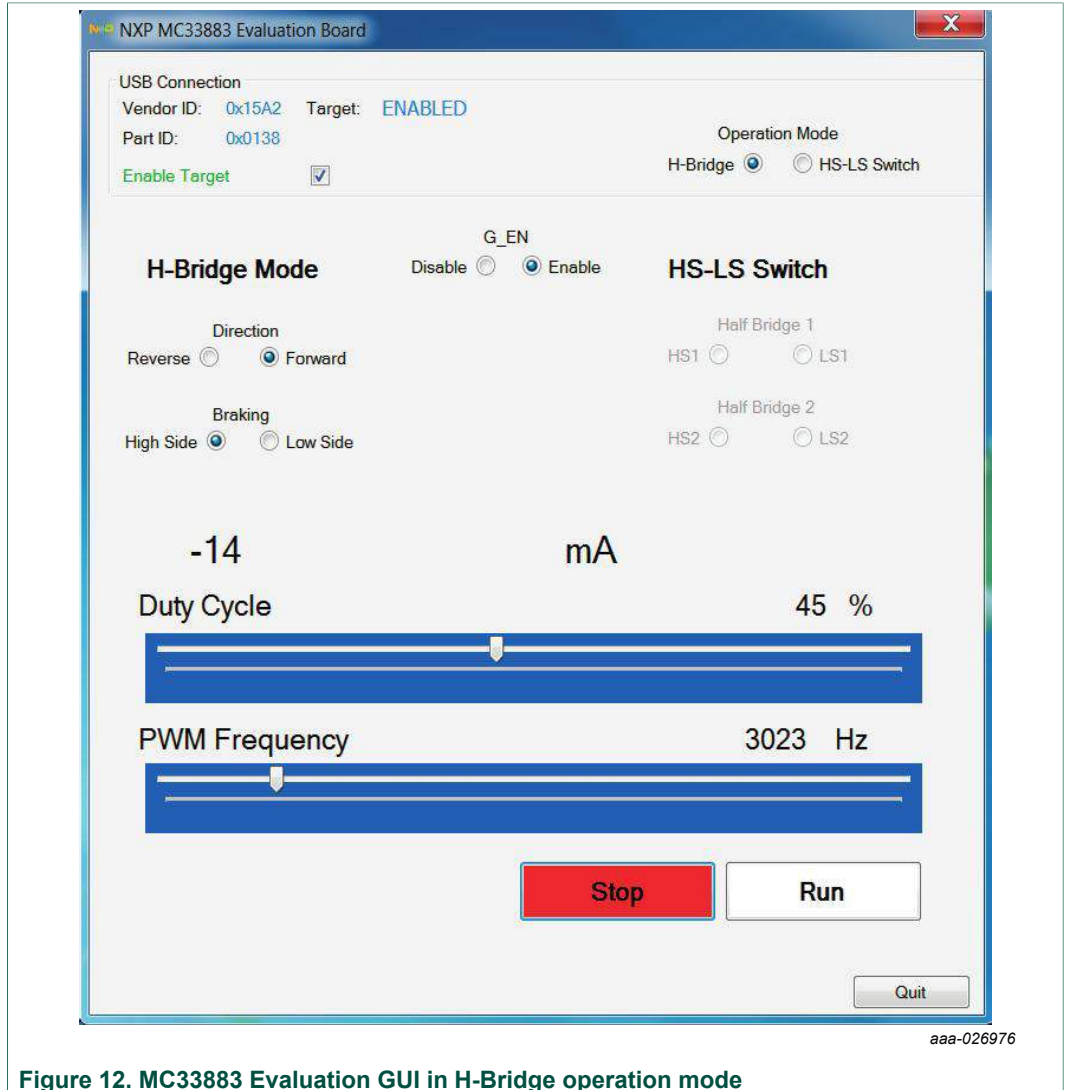

Figure 12. MC33883 Evaluation GUI in H-Bridge operation mode

Direction:

- **Forward:** Current flowing through OUT1 to OUT2
- **Reverse:** Current flowing through OUT2 to OUT1

Recirculation:

- **High-Side:** Freewheel-High (both high side FETs turned on) during PWMing
- **Low-Side:** Freewheel-Low (both low side FETs turned on) during PWMing (Only valid for Half-Bridge mode)

G_EN:

- **Enable:** EN is logic HIGH, the device is operational
- **Disable:** EN is logic LOW, the device is in sleep mode.

PWM Frequency:

- Enter PWM frequency up to 20kHz

Duty cycle (%):

- Select PWM duty cycle from 0-100%

Run:

- After selection of parallel control configuration, press Start to activate the outputs.

Stop:

- Press Stop to deactivate the outputs.

Current feedback:

Shows current through High-Side FET using the current recopy feature.

7.2 HS-LS Switch mode description

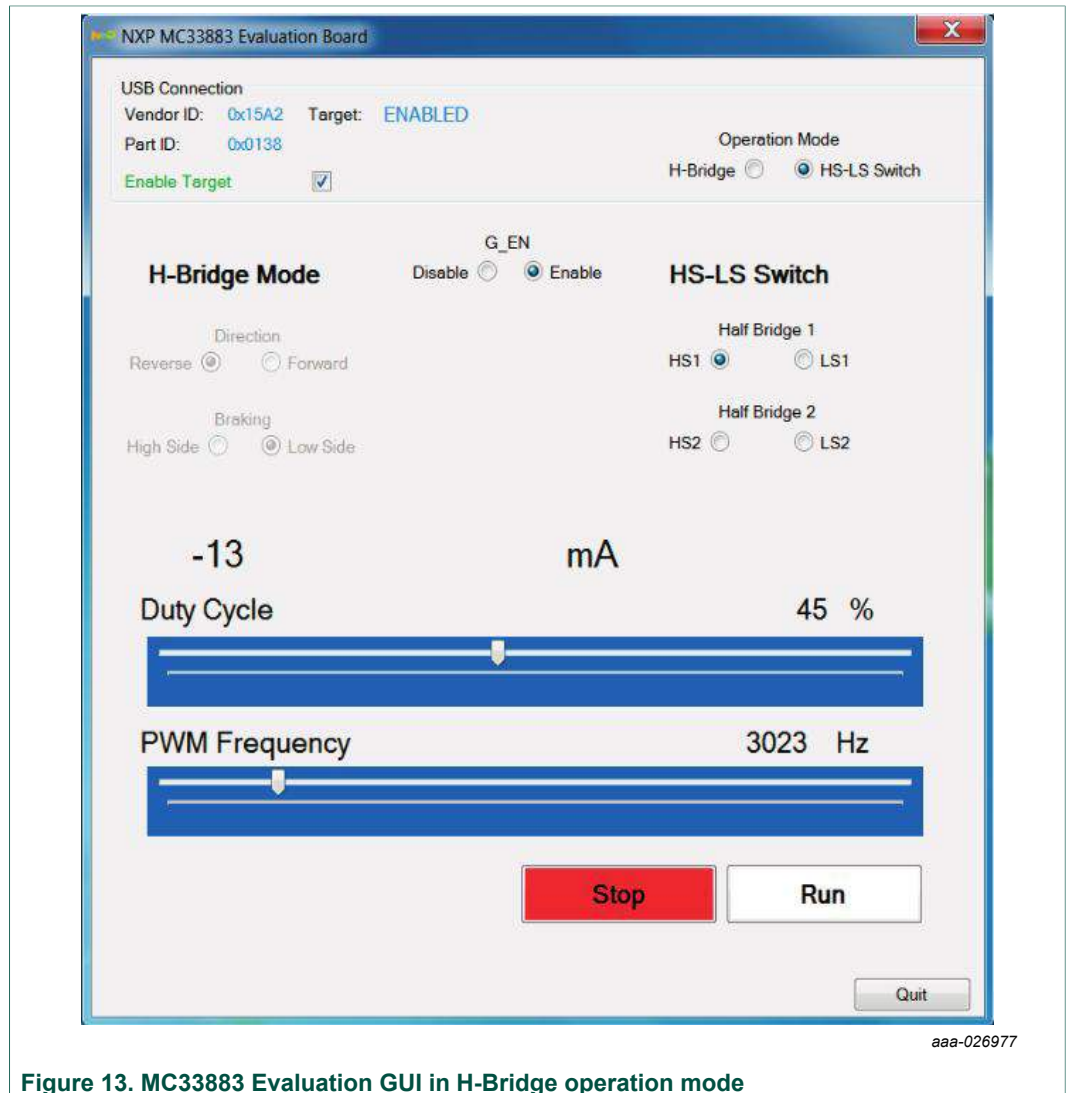
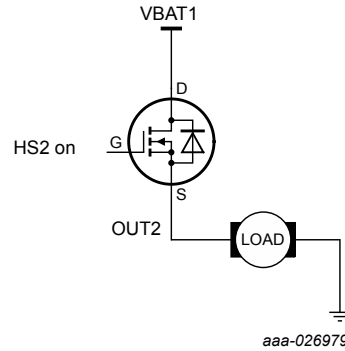
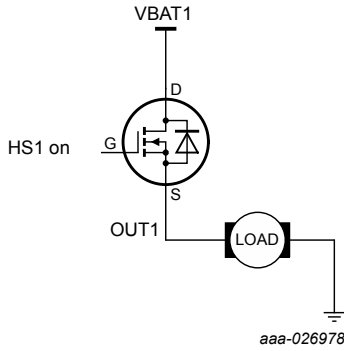

Figure 13. MC33883 Evaluation GUI in H-Bridge operation mode

Control:

HS1: Current flowing through HS1 to OUT1

HS2: Current flowing through HS2 to OUT2



LS1: Current flowing through LS1 to OUT1

LS2: Current flowing through LS2 to OUT2

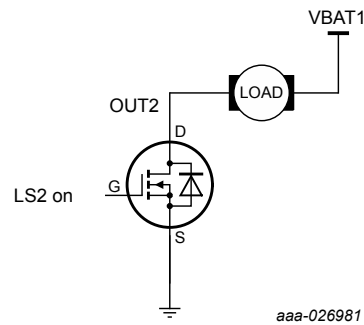
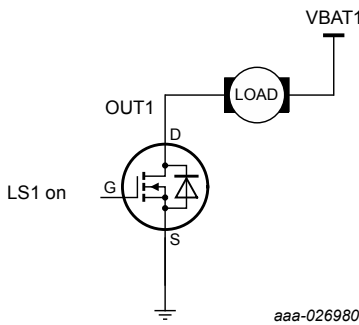

G_EN:

- **Enable:** EN is logic HIGH, the device is operational.
- **Disable:** EN is logic LOW, the device is in sleep mode.

PWM Frequency:

- Enter PWM frequency up to 20kHz. **Note:** FCC was tested at 10 kHz.

Duty cycle (%):

- Select PWM duty cycle from 0-100%

Run:

- After selection of parallel control configuration, press Start to activate the outputs.

Stop:

- Press Stop to deactivate the outputs.

Current Feedback:

Shows current valid only on Low-Side FETs using the current recopy feature. If both Low-Side FETs are used simultaneously Current Feedback will display summation of Low Side FETs.

8 Schematics, board layout and bill of materials

Board schematics, board layout and bill of materials are available in the download tab of the tool summary page for the associated board. See [Section 9 "References"](#) for a link to the relevant tool summary page.

9 References

Following are URLs where you can obtain information on related NXP products and application solutions:

Table 10. References

| NXP.com support pages | Description | URL |
|-----------------------|----------------------|--|
| KIT33883FRDMEVM | Tool summary page | www.nxp.com/KIT33883FRDMEVM |
| FRDM-KL25Z | Tool summary page | www.nxp.com/products/:FRDM-KL25Z |
| LVHBRIDGE-PEXPRT | Tool summary page | www.nxp.com/lvhbridge-pexpert |
| MC33883 | Product summary page | www.nxp.com/MC33883 |
| mbed | Home page | mbed.org |

10 Contact information

Visit www.nxp.com/support for a list of phone numbers within your region.

Visit www.nxp.com/warranty to submit a request for tool warranty.

11 Revision history

| Document ID | Release date | User guide status | Change notice | Supersedes |
|------------------------|--------------|-------------------|---------------|------------|
| KIT33883FRDMEVMUG v1.0 | 20170509 | Initial release | — | — |

12 Legal information

12.1 Definitions

Draft — The document is a draft version only. The content is still under internal review and subject to formal approval, which may result in modifications or additions. NXP Semiconductors does not give any representations or warranties as to the accuracy or completeness of information included herein and shall have no liability for the consequences of use of such information.

12.2 Disclaimers

Information in this document is provided solely to enable system and software implementers to use NXP products. There are no express or implied copyright licenses granted hereunder to design or fabricate any integrated circuits based on the information in this document. NXP reserves the right to make changes without further notice to any products herein.

NXP makes no warranty, representation, or guarantee regarding the suitability of its products for any particular purpose, nor does NXP assume any liability arising out of the application or use of any product or circuit,

and specifically disclaims any and all liability, including without limitation consequential or incidental damages. "Typical" parameters that may be provided in NXP data sheets and/or specifications can and do vary in different applications, and actual performance may vary over time. All operating parameters, including "typicals," must be validated for each customer application by customer's technical experts. NXP does not convey any license under its patent rights nor the rights of others. NXP sells products pursuant to standard terms and conditions of sale, which can be found at the following address: nxp.com/salestermsandconditions.

12.3 Trademarks

Notice: All referenced brands, product names, service names and trademarks are the property of their respective owners.

NXP — is a trademark of NXP B.V.

the NXP logo — is a trademark of NXP B.V.

Freescale — is a trademark of NXP B.V.

the Freescale logo — is a trademark of NXP B.V.

SMARTMOS — is a trademark of NXP B.V.

Tables

| | | | | | |
|---------|---------------------------------|---|----------|--|----|
| Tab. 1. | Device features | 5 | Tab. 7. | Screw terminal definitions | 10 |
| Tab. 2. | Board description | 7 | Tab. 8. | Jumpers | 10 |
| Tab. 3. | LED Display | 8 | Tab. 9. | KIT33883FRDM-EVM to FRDM-KL25Z connections | 12 |
| Tab. 4. | Test point definitions | 8 | Tab. 10. | References | 21 |
| Tab. 5. | Input signal definitions | 9 | | | |
| Tab. 6. | Output signal definitions | 9 | | | |

Figures

| | | | | | |
|---------|---|----|----------|---|----|
| Fig. 1. | KIT33883FRDM-EVM with FRDM-KL25Z Freedom Development Platform | 1 | Fig. 9. | MC33883 Evaluation GUI in H-Bridge operation mode | 14 |
| Fig. 2. | Block diagram | 4 | Fig. 10. | KIT33883FRDM-EVM plus FRDM-KL25Z board setup | 15 |
| Fig. 3. | H-Bridge modes of operation | 5 | Fig. 11. | MBED drive | 17 |
| Fig. 4. | Architecture MC33883 | 6 | Fig. 12. | MC33883 Evaluation GUI in H-Bridge operation mode | 18 |
| Fig. 5. | Board description | 7 | Fig. 13. | MC33883 Evaluation GUI in H-Bridge operation mode | 19 |
| Fig. 6. | Board description | 8 | | | |
| Fig. 7. | Board description | 10 | | | |
| Fig. 8. | Board description | 13 | | | |

Contents

| | | |
|-----------|---|-----------|
| 1 | KIT33883FRDM-EVM evaluation board | 1 |
| 2 | Important notice | 2 |
| 3 | Getting started | 3 |
| 3.1 | Kit contents and packing list | 3 |
| 3.2 | Jump start | 3 |
| 3.3 | Required equipment | 3 |
| 3.4 | System requirements | 3 |
| 4 | Getting to know the hardware | 4 |
| 4.1 | Board overview | 4 |
| 4.2 | Board features | 4 |
| 4.3 | Block diagram | 4 |
| 4.4 | Device features | 5 |
| 4.5 | Board description | 7 |
| 4.6 | LED display | 7 |
| 4.7 | Test point definitions | 8 |
| 4.8 | Input signal definitions | 9 |
| 4.9 | Output signal definitions | 9 |
| 4.10 | Screw terminal connections | 10 |
| 4.11 | Jumpers | 10 |
| 5 | FRDM-KL25Z Freedom Development Platform | 11 |
| 5.1 | Connecting a FRDM-KL25Z to the board | 11 |
| 6 | Setting up the hardware and software | 13 |
| 6.1 | Installing the Motor Control GUI on your computer | 13 |
| 6.2 | Setting up the hardware | 14 |
| 6.2.1 | Setting up the hardware using the GUI | 15 |
| 6.3 | Downloading software to the FRDM-KL25Z board | 16 |
| 6.3.1 | Downloading mbed® firmware to the FRDM-KL25Z board | 16 |
| 6.3.2 | Downloading the MC33883 microcode to the FRDM-KL25Z board | 16 |
| 7 | Using the GUI | 18 |
| 7.1 | H-Bridge mode description | 18 |
| 7.2 | HS-LS Switch mode description | 19 |
| 8 | Schematics, board layout and bill of materials | 21 |
| 9 | References | 21 |
| 10 | Contact information | 21 |
| 11 | Revision history | 21 |
| 12 | Legal information | 22 |

Please be aware that important notices concerning this document and the product(s) described herein, have been included in section 'Legal information'.

© NXP B.V. 2017.

All rights reserved.

For more information, please visit: <http://www.nxp.com>
 For sales office addresses, please send an email to: salesaddresses@nxp.com

Date of release: 9 May 2017