

# Customer Information Sheet

DRAWING No.: M80-5T202M3-22-000

SHEET 2 OF 2

IF IN DOUBT - ASK

©

NOT TO SCALE

THIRD ANGLE PROJECTION

ALL DIMENSIONS IN mm

## SPECIFICATIONS:

**MATERIAL:**  
 MOULDING: GLASS FILLED PPS, UL94V-0, BLACK  
 SIGNAL CONTACT: PHOSPHOR BRONZE  
 BOARD-MOUNT JACKSCREW, NUT: STAINLESS STEEL

**FINISH:**  
 SIGNAL CONTACT:  
 75µ GOLD ON CONTACT AREA,  
 3µ 100% TIN OVER NICKEL ON TAILS

**ELECTRICAL:**  
 WORKING VOLTAGE = 800V AC/DC  
 VOLTAGE PROOF = 1200V AC/DC  
 INSULATION RESISTANCE = 100MΩ MIN  
 SIGNAL CONTACT:

CURRENT RATING AT 25°C = 3.0A MAX  
 CURRENT RATING AT 85°C = 2.2A MAX  
 CONTACT RESISTANCE = 25mΩ MAX

**MECHANICAL:**  
 DURABILITY = 500 OPERATIONS  
 SIGNAL CONTACT:  
 INSERTION FORCE = 2.0N MAX  
 WITHDRAWAL FORCE = 0.2N MIN

**ENVIRONMENTAL:**  
 TEMPERATURE RANGE = -55°C TO +125°C

**PACKING:**  
 TUBE  
 FOR COMPLETE SPECIFICATION SEE COMPONENT  
 SPECIFICATION C005XX (LATEST ISSUE)

**NOTES:**  
 1. CONNECTORS ARE SUPPLIED WITH  
 NUTS LOOSE.

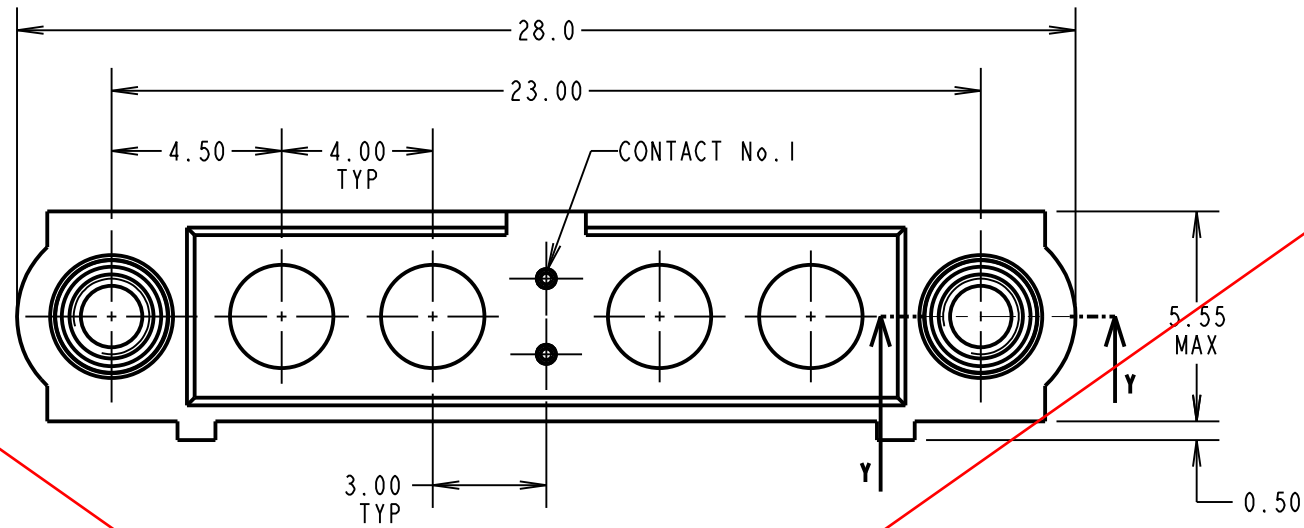

**OBSOLETE**

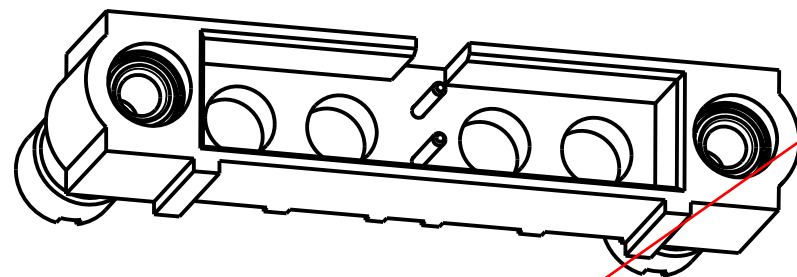
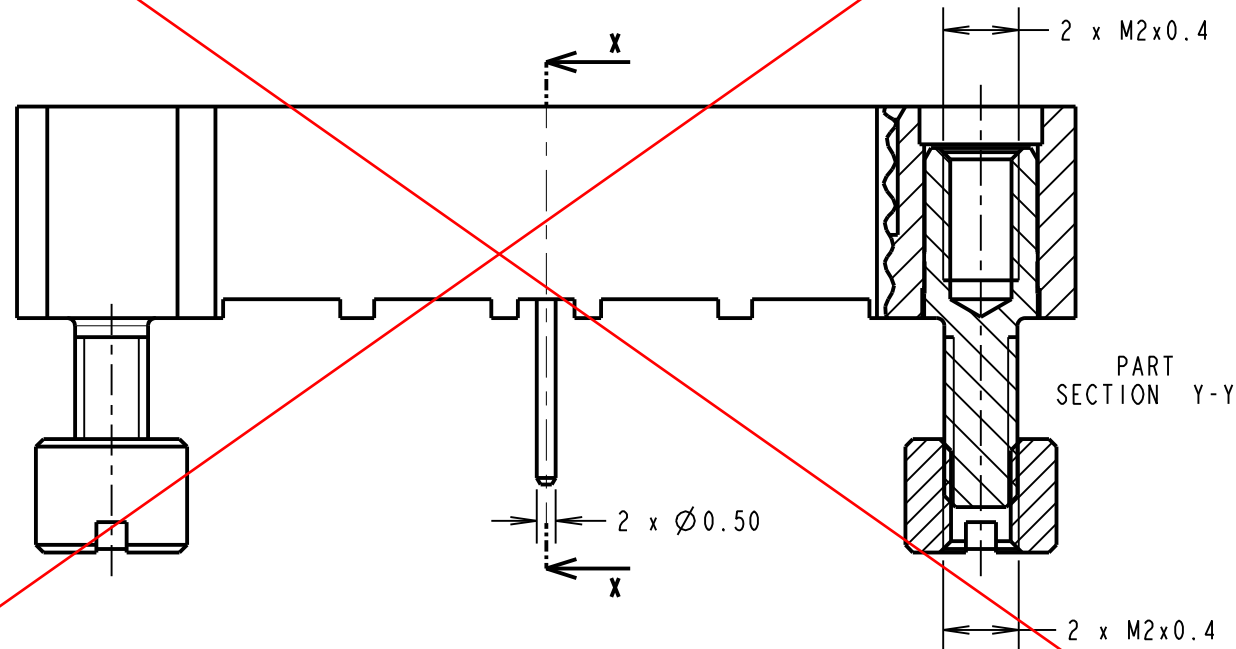

COMPLETE ASSEMBLY SHOWN  
 FOR ILLUSTRATION ONLY

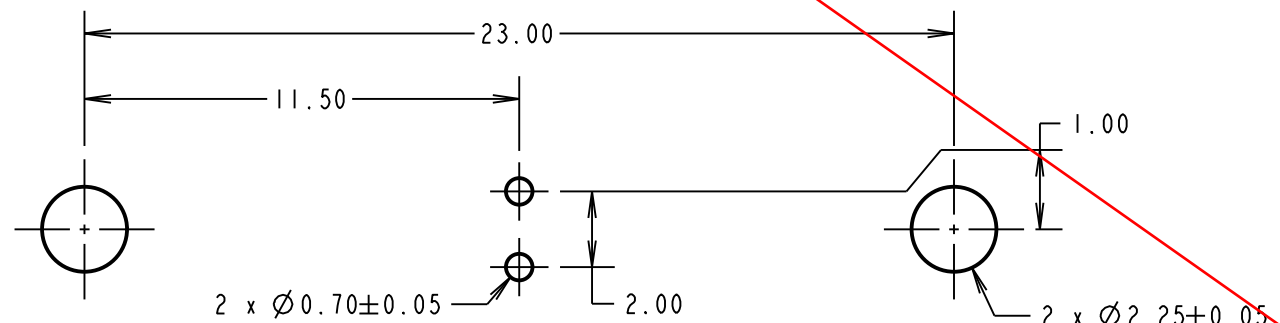

RECOMMENDED PCB LAYOUT

FM	2	11.09.17	13269
NAME	ISS.	DATE	C/NOTE
APPROVED:			
CHECKED:			
DRAWN: B. M. KENT			
CUSTOMER REF.:			
ASSEMBLY DRG:			

**HARWIN**

www.harwin.com  
 technical@harwin.com

THIS DRAWING AND ANY  
 INFORMATION OR DESCRIPTIVE  
 MATTER SET OUT HEREON ARE  
 CONFIDENTIAL AND COPYRIGHT  
 PROPERTY OF THE HARWIN  
 GROUP AND MUST NOT BE  
 DISCLOSED, LOANED, COPIED  
 OR USED FOR MANUFACTURING,  
 TENDERING OR FOR ANY  
 OTHER PURPOSE WITHOUT  
 THEIR WRITTEN PERMISSION.

**TOLERANCES**  
 X. = ±1mm  
 X.X = ±0.50mm  
 X.XX = ±0.10mm  
 X.XXX = ±0.01mm  
 ANGLES = ±5°  
 UNLESS STATED

**MATERIAL:**  
 SEE ABOVE  
**FINISH:** SEE ABOVE  
**S/AREA:** mm<sup>2</sup>

**TITLE:** JACKSCREW DATAMATE  
 MIXED TECHNOLOGY HORIZONTAL  
 PC TAIL MALE ASSEMBLY  
**DRAWING NUMBER:**  
 M80-5T202M3-22-000  
 SHT 2 OF 2