



TELEDYNE TEST TOOLS
Everywhereyoulook™

Rogowski Current Probes User Manual

T3RC0300-UM

T3RC0600-HF

T3RC3000-HF

T3RC3000-LF

T3RC6000-LF

INTRODUCTION3

TECHNICAL SPECIFICATION3

STANDARDS AND APPROVALS5

ROGOWSKI PROBES OVERVIEW6

T3RC0300-UM HANDLING INSTRUCTIONS7

T3RC0300-UM SAFETY AND PRE-USE CHECKS8

T3RC0600-HF AND T3RC3000-HF HANDLING INSTRUCTIONS9

T3RC0600-HF AND T3RC3000-HF SAFETY AND PRE-USE CHECKS10

T3RC3000-LF AND T3RC6000-LF HANDLING INSTRUCTIONS11

T3RC3000-LF AND T3RC3000-LF SAFETY AND PRE-USE CHECKS11

ADDITIONAL SAFETY AND PRE-USE CHECKS FOR ALL PROBES.....12

POWER OPTIONS13

REPLACING THE BATTERIES13

SWITCHING ON 13

OBTAINING THE BEST MEASUREMENT 14

CLEANING AND DECONTAMINATION 15

WARRANTY 15

RETURNING YOUR ROGOWSKI PROBE FOR RECALIBRATION OR REPAIR . 15

INTRODUCTION

The Teledyne Test Tools Rogowski Current Waveform Transducers combines high bandwidth performance with minimal disruption to the circuit under test. These instructions must be followed whenever the unit is used. They are intended to help you obtain the best and safest performance from the transducer.

Throughout these instructions there are a number of warnings which must be observed to ensure safe operation of the Teledyne Test Tools Rogowski probe. These warnings are identified by the following symbol:



The intended use is for the measurement of AC current. Teledyne Test Tools accepts no responsibility for any damage resulting from careless use, or failure to observe these instructions.

TECHNICAL SPECIFICATION

Peak Current	Refer to ID Label
Peak Output Voltage	±6V (corresponding to ±Peak Current Rating)
Output Cable	0.5m BNC to BNC 50Ω cable In order to maintain safety, the BNC terminal must be connected to equipment that is separated from hazardous voltages by at least double insulation.
Output Load	≥ 100kΩ (for rated accuracy – recommend DC1MΩ on scope) = 50Ω (The Integrator can drive a 50Ω load if necessary) NB. A load of 50Ω will reduce the Rogowski Probe sensitivity by half its normal value and limit the peak output voltage to ±2V.
Bandwidth (-3dB)	T3RC0300-UM: 9.2 Hz - 30 MHz T3RC0600-HF: 12 Hz - 30 MHz T3RC3000-HF: 3 Hz - 23 MHz T3RC3000-LF: 0.11 Hz - 6.5 MHz T3RC6000-LF: 0.055 Hz - 6.5 MHz
Operating Temp. Range T3RC0300-UM T3RC0600-HF T3RC3000-HF	0°C to +40°C (<i>Integrator electronics</i>) - 40°C to +125°C (<i>Coil and cable</i>)
Operating Temp. Range T3RC3000-LF T3RC6000-LF	0°C to +40°C (<i>Integrator electronics</i>) - 20°C to +100°C (<i>Coil and cable</i>)

Accuracy (typ.)	(5% to 100% Peak Current)	
Calibration	Nominally $\pm 0.2\%$ with the conductor central in the Rogowski loop. See the calibration certificate for further details.	
Positional Accuracy		
T3RC0300-UM	$\pm 2\%$ variation of accuracy with conductor position in the loop (see 'Obtaining The Best Measurement')	
T3RC0600-HF		
T3RC3000-HF		
T3RC3000-LF	$\pm 1\%$ variation of accuracy with conductor position in the loop (see 'Obtaining The Best Measurement')	
T3RC6000-LF		
Linearity	$\pm 0.05\%$ of reading	
Noise (Max)	T3RC0300-UM:	2.5 mV rms
	T3RC0600-HF:	1.7 mV rms
	T3RC3000-HF:	1.4 mV rms
	T3RC3000-LF:	2.5 mV rms
	T3RC6000-LF:	2.5 mV rms
Oscilloscope Attenuation Ratio (for correct Oscilloscope vertical scaling)	T3RC0300-UM:	50
	T3RC0600-HF:	100
	T3RC3000-HF:	500
	T3RC3000-LF:	500
	T3RC6000-LF:	1000
Coil Insulation	T3RC0300-UM:	1.2 kV peak
	T3RC0600-HF:	5 kV peak
	T3RC3000-HF:	5 kV peak
	T3RC3000-LF:	10 kV peak
	T3RC6000-LF:	10 kV peak
Absolute di/dt Ratings	T3RC0300-UM:	20 kA/us
	T3RC0600-HF:	40 kA/us
	T3RC3000-HF:	80 kA/us
	T3RC3000-LF:	11 kA/us
	T3RC6000-LF:	11 kA/us
Environmental	Indoor use / Altitude up to 2000m Installation Category II, Pollution Degree 2. Max. Rel. Humidity: 80% up to 31°C Decreasing Linearly to 50% at 40°C	
Overvoltage Transient	T3RC0300-UM:	Cat II 600V
	T3RC0600-HF:	Cat III 600V
	T3RC3000-HF:	Cat III 600V
	T3RC3000-LF:	Cat III 1000V
	T3RC6000-LF:	Cat III 1000V

Operation with External Adaptor

DC Supply Voltage	12Vdc (+/-10%)
DC Quiescent Current	60mA @12VDC – using standard alkaline battery 130mA @ 12VDC – using NiMH Rechargeable battery
DC Socket Type	1.3mm jack socket – Centre Positive Tip

The unit should only be powered by the supplied mains adaptor.

Adaptor Supply Voltage	100 – 240VAC
Adaptor Supply Frequency	50 - 60Hz
Adaptor Supply Current	450mA Max @ 100VAC Input
Supply Voltage Fluctuation	up to 10%

Operation with Battery

Battery Supply	Using 4 x 1.5V AA alkaline Battery Life: 25hrs typ. Using 4 x 1.2V NiMH rechargeable batteries Battery Life: 10hrs typ. (based on a 2000mAh cell) Typical Recharge Time: 40 hrs
----------------	--

STANDARDS AND APPROVALS

EMC Approvals	EN61326-1:2013 FCC Title 47 (CFR:2010, Part 15b)
Safety Approvals	EN61010-1:2010 EN61010-2-032:2012
Quality System	ISO9001:2015



Teledyne Test Tools Rogowski Probes Overview

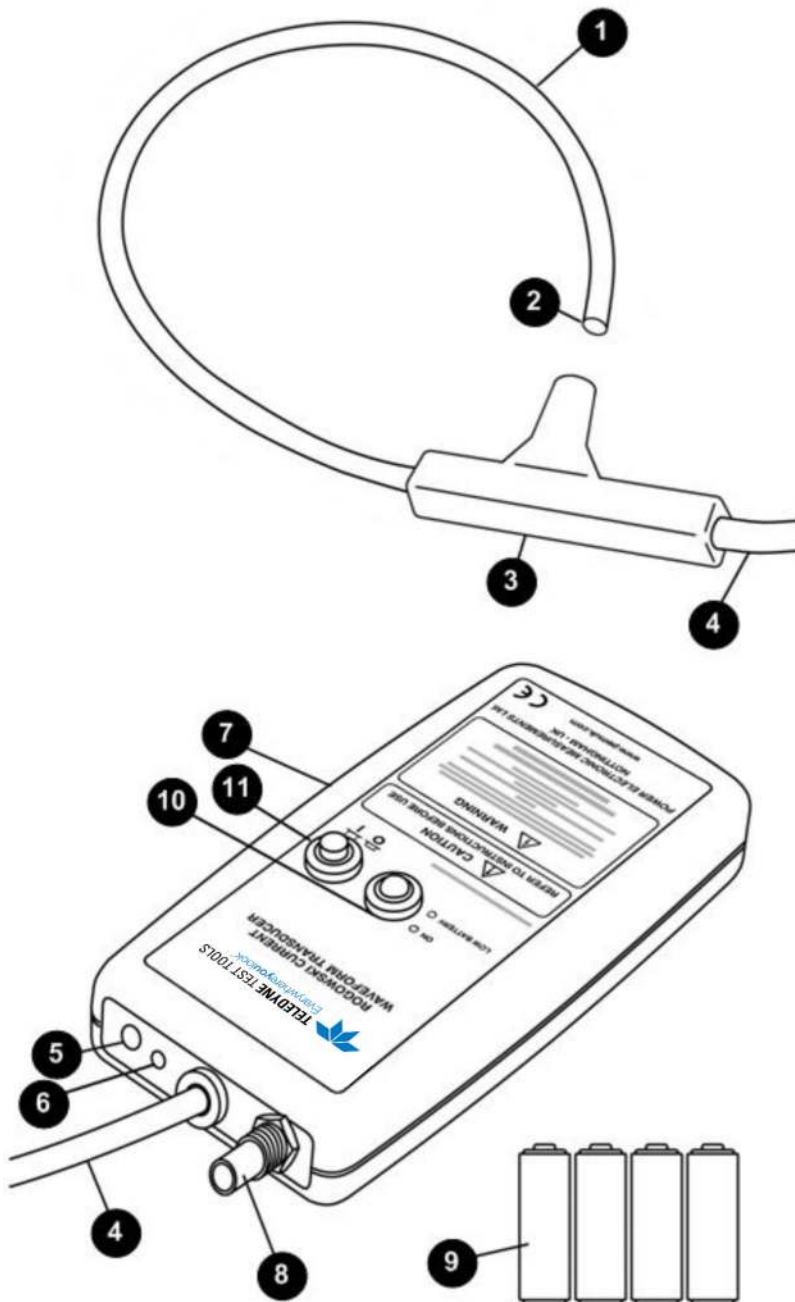

1. Rogowski Coil (Probe)
2. Probe 'Free End'
3. Ferrule
4. Connecting Cable
5. DC Power Socket
6. DC Power Status LED
7. Enclosure
8. BNC Output Socket
9. 4 x AA batteries
10. Status Indicator LED
GREEN = ON
RED = Battery LOW
11. Power Button

T3RC0300-UM HANDLING INSTRUCTIONS

Every effort has been made to ensure that the T3RC0300-UM is as robust as possible. To achieve such an extremely thin Rogowski coil the T3RC0300-UM is necessarily delicate.

To prolong the life of the coil please observe the following handling instructions.

When fully inserted the ferrule will grip the coil.



When clipping or unclipping the coil, hold the ferrule as shown

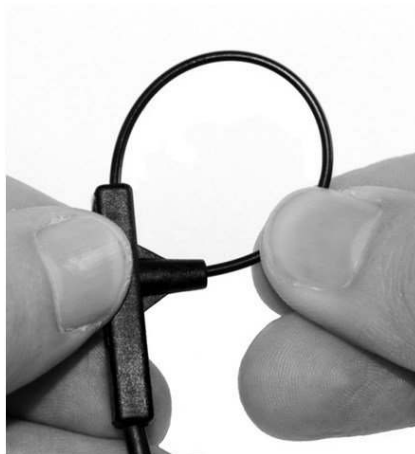

Never force the free end of the coil into the ferrule. This may damage the coil insulation.



Take care not to put any force onto the cable attached to the coil. This may damage the coil.



When not in use return the coil to its protective case.



The minimum bend radius of this coil is 10mm. This is the minimum radius that the coil can be bent without causing damage or shortening its life.

T3RC0300-UM SAFETY AND PRE-USE CHECKS



The integrity of the insulation around the Rogowski coil itself must be VISUALLY INSPECTED before use, and the T3RC0300-UM must NOT BE USED if there are signs of damage.



When bending the flexible coil around a conductor, avoid tight bends and sharp edges that could damage the coil.



The voltage rating (safe PEAK working voltage) is clearly labelled on the cable adjacent to the coil. For the T3RC0300-UM Ultra Mini this is 1.2kV peak. Never use at voltages greater than this value.



Voltage ratings are only valid if the 'free end' of the coil is fully inserted into the socket, and remains fully inserted during use. The coil has a friction fit, the coil is fully inserted when the user feels they can ease the coil free end into the ferrule no further.



The voltage ratings are appropriate for intermittent use of the T3RC0300-UM as a test instrument and not for continuous use in a permanent installation.

The ratings are derived from the following standard test: Coils rated for 1.2kV peak are flash tested for one minute at 3.0kVrms using a 50Hz sine-wave voltage.

For permanent installation the coil should be situated such that corona, which will eventually damage the coil insulation, cannot occur. For information regarding permanent installation of Teledyne Test Tools Rogowski coils on high voltage equipment please consult Teledyne Test Tools.



The user must ensure that the absolute maximum rated di/dt is not exceeded.

THE INTEGRATOR



The T3RC0300-UM must only be used with oscilloscopes or monitoring equipment which have their BNC INPUTS PROPERLY GROUNDED.

T3RC0600-HF AND T3RC3000-HF HANDLING INSTRUCTIONS

To achieve such an extremely thin Rogowski coil, the T3RC0600-HF and T3RC3000-HF are necessarily delicate.

Every effort has been made to ensure that the T3RC0600-HF and T3RC3000-HF are as robust as possible. To prolong the life of the coil please observe the following handling instructions.

Releasing The Coil

The free end of the coil is unclipped by applying gentle pressure in the direction shown.

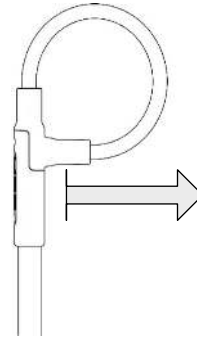

Correct Coil Insertion

The coil is correctly positioned when the free end of the coil is fully inserted into the ferrule.

When correctly inserted, the ferrule will grip the coil and hold it securely.

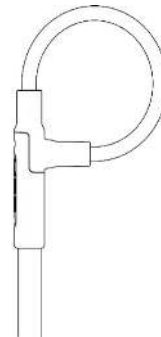

Never force the free end of the coil into the ferrule. This may damage the coil insulation.



Take care not to put any force onto the cable attached to the coil. This may damage the coil.



When not in use return the Rogowski coil to its protective case.



The minimum bend radius of this coil is 14mm. This is the minimum radius that the coil can be bent without risk of damaging the coil or shortening its life.

T3RC0600-HF and T3RC3000-HF SAFETY AND PRE-USE CHECKS



The integrity of the insulation around the Rogowski coil itself must be VISUALLY INSPECTED before use, and the T3RC0600-HF and T3RC3000-HF must NOT BE USED if there are signs of damage.



When bending the flexible coil around a conductor, avoid tight bends and sharp edges that could damage the coil.



The voltage rating (safe PEAK working voltage) is clearly labelled on the cable adjacent to the coil. For the T3RC0600-HF and T3RC3000-HF this is 5kV peak. Never use at voltages greater than this value.



Voltage ratings are only valid if the 'free end' of the coil is fully inserted into the socket, and remains fully inserted during use. The coil has a friction fit, the coil is fully inserted when the user feels they can ease the coil free end into the ferrule no further.



The voltage ratings are appropriate for intermittent use of the T3RC0600-HF and T3RC3000-HF as a test instrument and not for continuous use in a permanent installation.

The ratings are derived from the following standard test: Coils rated for 5kV peak are flash tested for one minute at 8kVrms using a 50Hz sine-wave voltage.

For permanent installation the coil should be situated such that corona, which will eventually damage the coil insulation, cannot occur. For information regarding permanent installation of Teledyne Test Tools Rogowski coils on high voltage equipment please consult Teledyne Test Tools.



The user must ensure that the absolute maximum rated di/dt is not exceeded

THE INTEGRATOR



The T3RC0600-HF and T3RC3000-HF must only be used with oscilloscopes or monitoring equipment which have their BNC INPUTS PROPERLY GROUNDED.

T3RC3000-LF AND T3RC6000-LF HANDLING INSTRUCTIONS

The coil free end is fully inserted in the ferrule when the user feels the free end of the coil engage with the internal click-in mechanism inside the ferrule.

Visual indication that the coil mechanism is fully inserted is provided by the black coil marker situated near the end of the coil, as shown below:

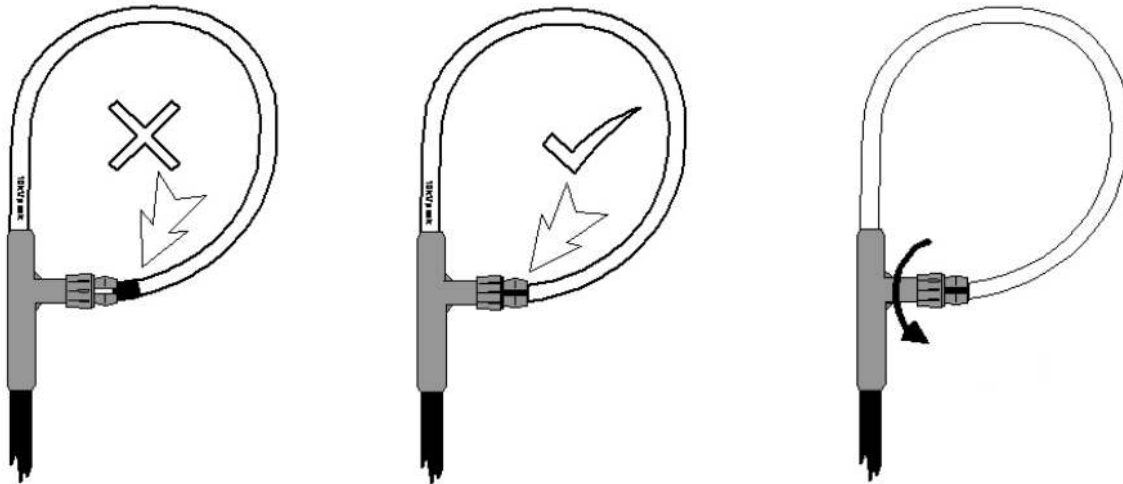

Once the free end of the coil is fully engaged in the ferrule, turn the ferrule lock nut to lock the coil end in position.

To remove the probe from the device under test first loosen the ferrule lock nut then remove the coil end from the ferrule.



The locking mechanism must not be actuated at temperatures below 0 C.



Care must be taken not to over-tighten the locking nut.



When not in use return the Rogowski probe to its protective case.

T3RC3000-LF and T3RC6000-LF SAFETY AND PRE-USE CHECKS



The integrity of the insulation around the Rogowski coil itself must be VISUALLY INSPECTED before use, and the T3RC3000-LF and T36000-LF must NOT BE USED if there are signs of damage.



When bending the flexible coil around a conductor, avoid tight bends and sharp edges that could damage the coil.



The voltage rating (safe PEAK working voltage) is clearly labelled on the cable adjacent to the coil. For the T3RC3000-LF and T36000-LF this is 10kV peak. Never use at voltages greater than this value.



Voltage ratings are only valid if the 'free end' of the coil is fully inserted into the socket, and remains fully inserted during use i.e. right up to the black indicator line on the free end of the coil.



The voltage ratings are appropriate for intermittent use of the T3RC3000-LF and T36000-LF as a test instrument and not for continuous use in a permanent installation.

The ratings are derived from the following standard test: Coils rated for 10kV peak are flash tested for one minute at 15kVrms using a 50Hz sine-wave voltage.

For permanent installation the coil should be situated such that corona, which will eventually damage the coil insulation, cannot occur. For information regarding permanent installation of Teledyne Test Tools Rogowski coils on high voltage equipment please consult Teledyne Test Tools.



The user must ensure that the absolute maximum rated di/dt is not exceeded

THE INTEGRATOR



The Rogowski probe must only be used with oscilloscopes or monitoring equipment which have their BNC INPUTS PROPERLY GROUNDED.

SAFETY AND PRE-USE CHECKS FOR ALL TELEDYNE TEST TOOLS ROGOWSKI PROBES



The Teledyne Test Tools Rogowski probes do not provide protection of the user from electric shock whilst applying or removing the probe from HAZARDOUS LIVE conductors. Additional protective means are necessary to avoid electric shock from HAZARDOUS LIVE conductors which cannot be de-energised.

If HAZARDOUS LIVE voltages are present and accessible in the installation, appropriate protective equipment must be used.

The Rogowski coil must not be used if the coil outer layer is damaged or in any way compromised.

The Teledyne Test Tools Rogowski probes must only be used in conjunction with properly earthed test equipment.

If the Teledyne Test Tools Rogowski probes are used in a manner not specified by the manufacturer the protection provided by the equipment may be impaired.

POWER OPTIONS

The Teledyne Test Tools Rogowski probes can be powered by an external DC source or by battery.

External Supply

The Teledyne Test Tools Rogowski probes can be powered by an external DC supply. The DC voltage must be 12V($\pm 10\%$) using a centre positive connector. When the DC supply is present a RED indicating LED adjacent to the socket is illuminated.

Standard Alkaline Batteries

Four fully charged AA alkaline batteries provide approx. 25 hours operation. Healthy batteries are indicated by the GREEN LED. If the LED is RED the batteries are depleted and must be replaced.

When the DC voltage is present the batteries are inoperative.

REPLACING THE BATTERIES

Low battery is indicated by a red LED located near the power switch. To replace the batteries, switch-off the Rogowski probe integrator, remove the battery cover and replace with appropriate batteries for your Teledyne Test Tools Rogowski probe type.

It is recommended that the circuit under test is de-energised or the probe is removed from the test circuit before replacing the batteries.

SWITCHING ON



Before installing the Rogowski probe and taking a measurement refer to SAFETY AND PRE-USE CHECKS and HANDLING INSTRUCTIONS to ensure safe operation of your Rogowski probe.



Your Rogowski probe must only be used with oscilloscopes or monitoring equipment which have their BNC inputs properly grounded.



The user is advised to de-energise the circuit under test first. If the probe is being fitted to a live circuit the user must ensure the use of appropriate personal protective equipment.

1. Connect the BNC output of the transducer to your grounded oscilloscope or current monitoring equipment.
2. Having carried out the VISUAL INSPECTION of the Rogowski coil, unclip the coil and wrap it around the de-energised conductor under test.

3. Insert the 'free end' of the coil fully inside the ferrule.
4. Re-energise the conductor.
5. Use the push button to switch ON by pressing and releasing the button, and to turn OFF by depressing the button fully; the LED indicates that the transducer is ON when the LED is GREEN.
6. After switch-on the Teledyne Test Tools Rogowski probes, they may require a settling period of up to 2 minutes before providing a correct current measurement. The settling period is dependent on warm-up time and the low frequency bandwidth.

OBTAINING THE BEST MEASUREMENT

The Rogowski coil should be positioned so that the conductor under test is encircled by the coil but is not adjacent to the cable attachment (see picture below). The diagram shows the direction a positive current should pass through the coil loop in order to obtain a positive output voltage. The Teledyne Test Tools Rogowski probe has been calibrated with the conductor near the centre (position **A**), and this is the ideal position for accuracy.

For the best high frequency performance, the centre of the current should lie on the line shown **A** to **B**, where **B** is half way around the circumference of the coil.

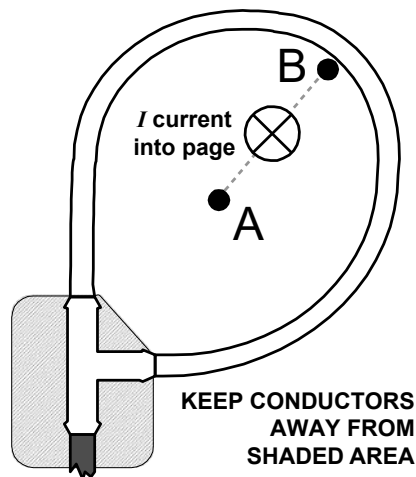

SENSITIVITY TO EXTERNAL CURRENTS AND VOLTAGES

The sensitivity of the Teledyne Test Tools Rogowski probes to currents that are outside the closed loop of the Rogowski coil is very small, provided that the external currents are less than the current rating of the Teledyne Test Tools Rogowski probes or that such currents are relatively distant from the coil. In the vicinity of a multi-turn conductor the effects are far stronger than from a single conductor carrying the same current, and such positions should be avoided.

If there is a surface with a high voltage very close to the coil and the voltage is subject to high rates of change or high frequency oscillations in the MHz range, then measurement error can arise due to capacitive coupling to the coil.

To check for any unwanted response to adjacent fields, it is recommended to quantify the output of the Teledyne Test Tools Rogowski probes when close to (but not encircling) the conductor under test. This will reveal the magnitude of any unwanted responses to currents close to, but outside, the coil.

OUTPUT CABLES

Your Teledyne Test Tools Rogowski probe has been supplied with a 50ohm BNC to BNC output cable. It is possible to use longer cables and these should be of a 50ohm single screened co-axial cable type.

Teledyne Test Tools does not consider the use of extension cables to be problematic from the noise viewpoint but consideration should be given to the routing of very long cables.

CLEANING AND DECONTAMINATION

To prevent surface contamination the Rogowski coil and cable should be inspected regularly.

The Rogowski coil must be disconnected from any external circuit and turned OFF prior to cleaning. To clean the coil and cable use a mild detergent and a damp cloth to remove any contamination, wipe dry with clean cloth to remove the detergent and dry thoroughly before placing back into service.

Teledyne Test Tools accepts no responsibility for the use of any other cleaning solvents or cleaning methods.

WARRANTY

The Rogowski probe is guaranteed to be free from defects due to materials and workmanship for 1 year.

In the event of a defect where the transducer has not been misused the Rogowski probe should be returned to Teledyne Test Tools with freight charges to be paid by the customer. Correction shall be in the form of repair or replacement.

RETURNING YOUR ROGOWSKI PROBE FOR RECALIBRATION OR REPAIR

To return the Rogowski probe to Teledyne Test Tools for repair or recalibration please contact Teledyne LeCroy in advance for shipping instructions (refer to information on the back page for contact details and our service procedure).

ABOUT TELEDYNE TEST TOOLS



Company Profile

Teledyne LeCroy is a leading provider of oscilloscopes, protocol analyzers and related test and measurement solutions that enable companies across a wide range of industries to design and test electronic devices of all types. Since our founding in 1964, we have focused on creating products that improve productivity by helping engineers resolve design issues faster and more effectively. Oscilloscopes are tools used by designers and engineers to measure and analyze complex electronic signals in order to develop high-performance systems and to validate electronic designs in order to improve time to market.

The Teledyne Test Tools brand extends the Teledyne LeCroy product portfolio with a comprehensive range of test equipment solutions. This new range of products delivers a broad range of quality test solutions that enable engineers to rapidly validate product and design and reduce time-to-market. Designers, engineers and educators rely on Teledyne Test Tools solutions to meet their most challenging needs for testing, education and electronics validation.

Location and Facilities

Headquartered in Chestnut Ridge, New York, Teledyne Test Tools and Teledyne LeCroy has sales, service and development subsidiaries in the US and throughout Europe and Asia. Teledyne Test Tools and Teledyne LeCroy products are employed across a wide variety of industries, including semiconductor, computer, consumer electronics, education, military/aerospace, automotive/industrial, and telecommunications.

Distributed by:

Teledyne LeCroy (US Headquarters)

700 Chestnut Ridge Road
Chestnut Ridge, NY. USA 10977-6499

Phone: 800-553-2769 or 845-425-2000
Fax Sales: 845-578-5985
Phone Support: 1-800-553-2769
Email Sales: contact.corp@teledynelecroy.com
Email Support: support@teledynelecroy.com
Web Site: <http://teledynelecroy.com>

World wide support contacts can be found at:
<https://teledynelecroy.com/support/contact>

World wide instrument service can be found at:
<https://teledynelecroy.com/support/service.aspx>

RoHS and WEEE information can be found at:
<https://teledynelecroy.com/support/rohs.aspx>

teledynelecroy.com



© 2018 Teledyne Test Tools is a brand and trademark of Teledyne LeCroy Inc. All rights reserved. Specifications, prices, availability and delivery subject to change without notice. Product brand or brand names are trademarks or requested trademarks of their respective holders.

T3 stands for Teledyne Test Tools.

30Apr2019