

PRODUCT DATA DRAWING

REVISION HISTORY			
REV	DESCRIPTION	DATE	APPROVED
-	DCN 49527	12/19	STW

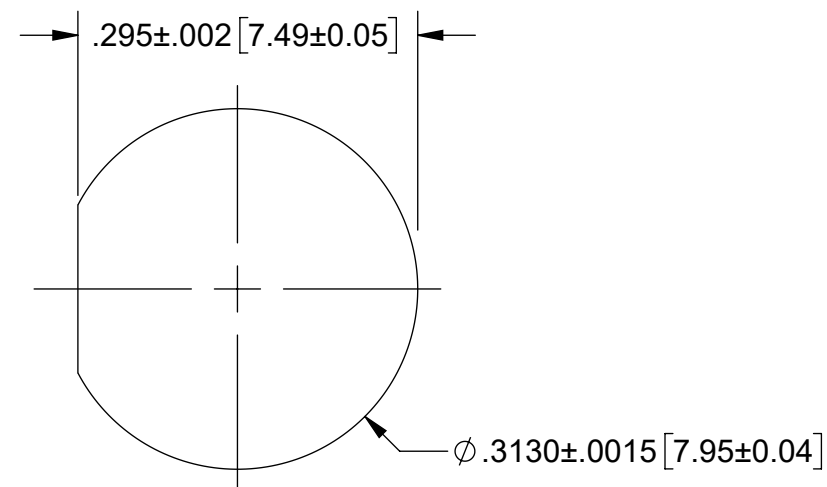
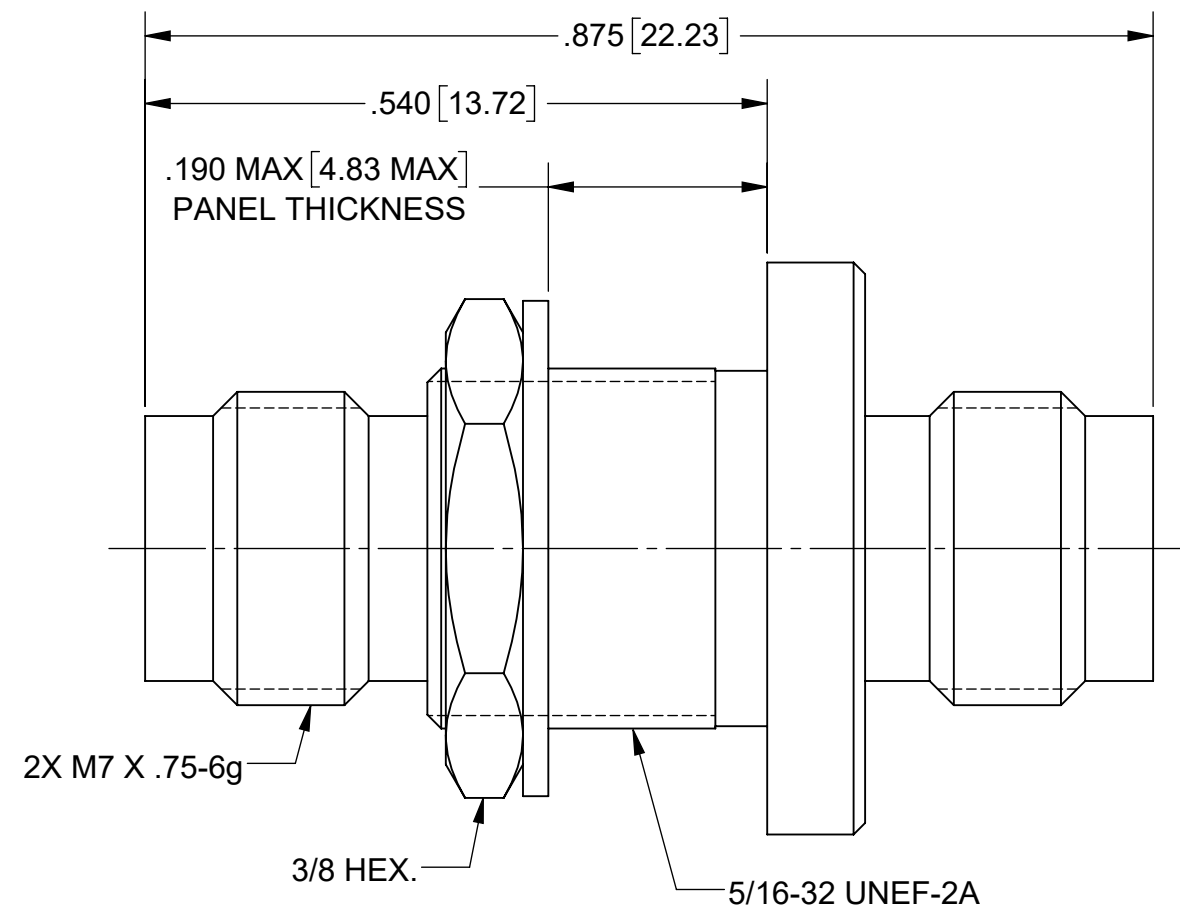
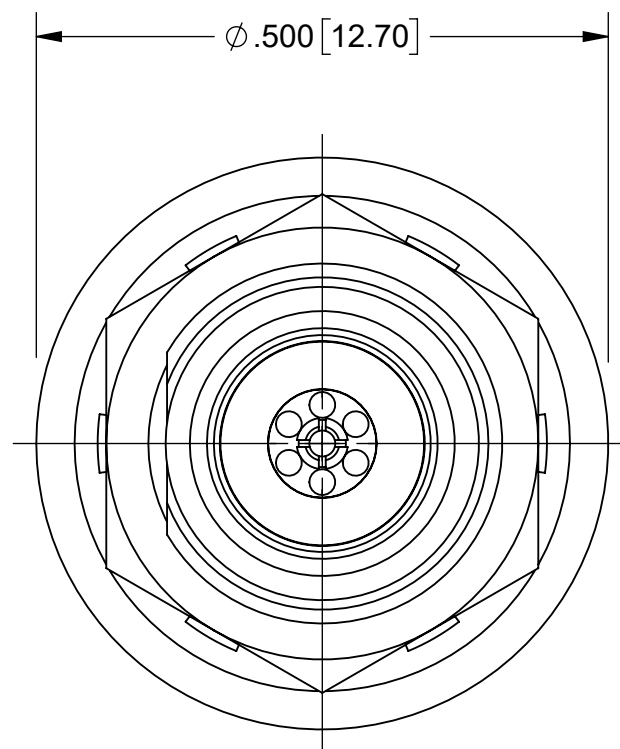
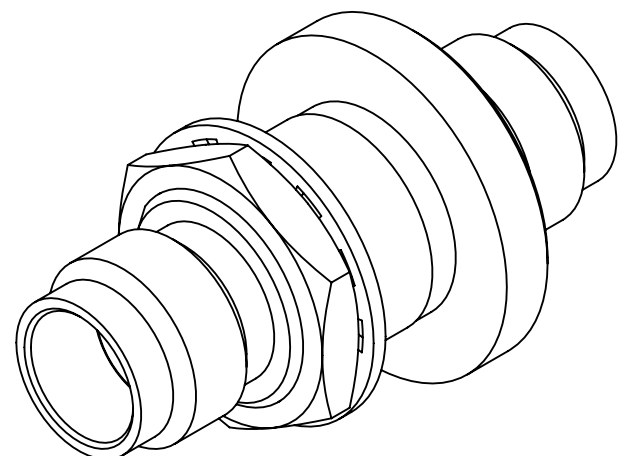

RECOMMENDED MOUNTING HOLE

MATERIAL:

BODY & HEX NUT: STAINLESS STEEL PER AMS-5640, ALLOY UNS S30300, TYPE 1; OR ASTM A582 TYPE 303, COND. A

CONTACT: BERYLLIUM COPPER PER ASTM B196, ALLOY No. UNS C17300, TD04

INSULATOR BEAD: POLYETHERIMIDE RESIN (ULTEM 1000) PER ASTM D5205

LOCKWASHER: 400 SERIES STAINLESS STEEL

FINISH:

BODY, HEX NUT & LOCKWASHER: PASSIVATED PER AMS-2700

CONTACT: GOLD PER ASTM B488, TYPE II, CODE C, CLASS 1.27, OVER NICKEL PER AMS-QQ-N-290, CLASS 1, .00005" MIN.

PERFORMANCE:

IMPEDANCE: 50 OHMS
FREQ. RANGE: DC TO 50.0 GHz.
VSWR: 1.11 MAX. DC TO 18.0 GHz.
 1.13 MAX. 18.0 TO 25.5 GHz.
 1.29 MAX. 25.5 TO 50.0 GHz.
INSERTION LOSS: .07 x (f)^{1/2}, f in GHz.

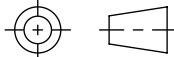
MATERIAL: SEE NOTES	DIMENSIONS ARE IN INCHES TOLERANCES: FRACTIONAL: $\pm 1/64$ ANGULAR: X° $\pm 1'0''$ X°X' $\pm 15''$	UNLESS OTHERWISE SPECIFIED 1) ALL DIMENSIONS ARE IN INCHES (MILLIMETERS) 2) ALL DIMENSIONS ARE AFTER PLATING. 3) BREAK CORNERS & EDGES .005 R. MAX. 4) CHAM. 1ST & LAST THREADS. 5) SURFACE ROUGHNESS 63-MIL-STD-10. 6) DIA: 'S ON COMMON CENTERS TO BE CONCENTRIC WITHIN .003 T.I.R. 7) REMOVE ALL BURRS	 TITLE: 2.4mm FEMALE TO FEMALE BULKHEAD ADAPTER
FINISH: SEE NOTES	DECIMAL: X $\pm .030$.XX $\pm .010$.XXX $\pm .005$	INTERPRET DIMENSIONS AND TOLERANCES PER ASME Y14.5M - 1994	
SURFACE AREA: N/A	THIRD ANGLE PROJECTION	DRAWN: MKK 12/30/19	SIZE DWG. NO. SF1116-6083
PROPRIETARY THE INFORMATION CONTAINED IN THIS DRAWING IS THE SOLE PROPERTY OF SV MICROWAVE, INC. ANY REPRODUCTION IN PART OR AS A WHOLE WITHOUT THE WRITTEN PERMISSION OF SV MICROWAVE, INC IS PROHIBITED.		CHECKED: STW 12/30/19	SCALE: 6:1
		APPROVED: STW 12/30/19	SHEET 1 OF 1