

PRODUCT DATA DRAWING

REVISION HISTORY			
REV	DESCRIPTION	DATE	APPROVED
C	DCN 48136	11/18	STW

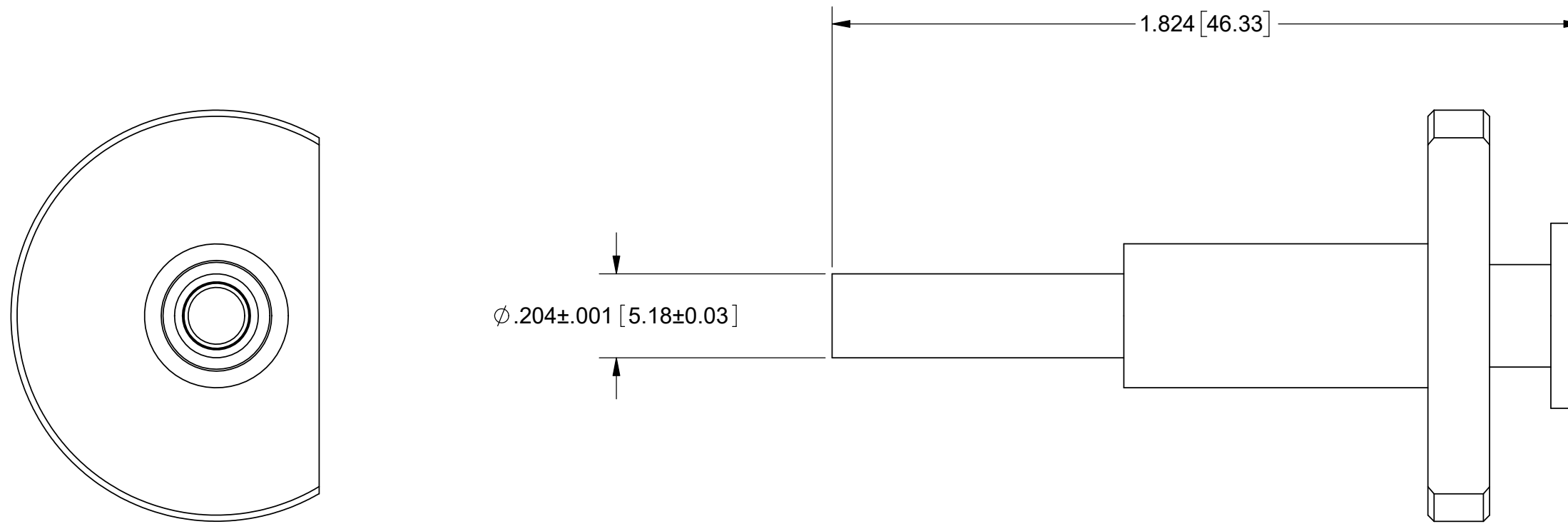

MATERIAL

- BODY: STAINLESS STEEL PER ASTM A630, ALLOY UNS S17400, CONDITION A.
- PUSH ROD & PLUNGER: STAINLESS STEEL PER AMS-5640, ALLOY UNS S30300, TYPE 1
- SPRING: MUSIC WIRE
- FINISH**
- PUSH ROD & PLUNGER: PASSIVATED PER AMS-2700.
- BODY: ELECTROLESS NICKEL PER SAE 2404, CLASS 1.

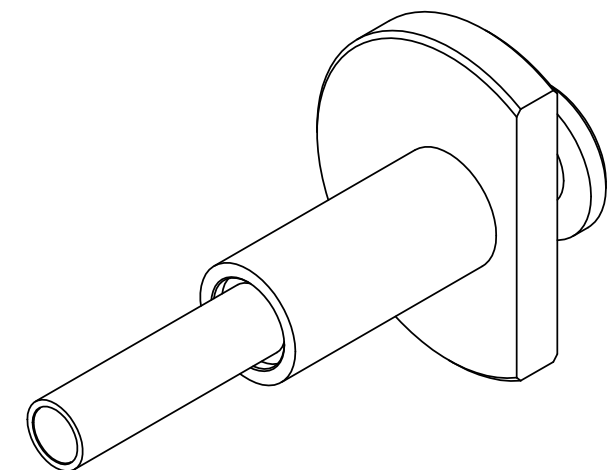

- NOTES:
1. REMOVAL TOOL FOR 3221-40019 & 3221-40022.
 2. USED ON 67.X CONTACTS, RESPECTIVELY

MATERIAL: SEE NOTES	DIMENSIONS ARE IN INCHES TOLERANCES: FRACTIONAL: $\pm 1/64$ ANGULAR: X° $\pm 1'0''$ X°X' $\pm 15''$	UNLESS OTHERWISE SPECIFIED 1) ALL DIMENSIONS ARE IN INCHES (MILLIMETERS) 2) ALL DIMENSIONS ARE AFTER PLATING. 3) BREAK CORNERS & EDGES .005 R. MAX. 4) CHAM. 1ST & LAST THREADS. 5) SURFACE ROUGHNESS 63-MIL-STD-10. 6) DIA. 'S ON COMMON CENTERS TO BE CONCENTRIC WITHIN .005 T.I.R. 7) REMOVE ALL BURRS	SV Microwave, Inc. 2400 Centrepark West Drive, Suite 100 West Palm Beach, FL 33409 TITLE: VITA 67.1/2 PLUG-IN CONTACT REMOVAL TOOL
FINISH: SEE NOTES	DECIMAL: X $\pm .030$.XX $\pm .010$.XXX $\pm .005$	INTERPRET DIMENSIONS AND TOLERANCES PER ASME Y14.5M - 1994	
SURFACE AREA: N/A	THIRD ANGLE PROJECTION	DRAWN: JMC 03/09/12	SIZE: B CAGE CODE: 95077 DWG. NO.: 500-32-022
PROPRIETARY THE INFORMATION CONTAINED IN THIS DRAWING IS THE SOLE PROPERTY OF SV MICROWAVE, INC. ANY REPRODUCTION IN PART OR AS A WHOLE WITHOUT THE WRITTEN PERMISSION OF SV MICROWAVE, INC IS PROHIBITED.		CHECKED: STW 03/09/12	SCALE: 3:1
		APPROVED: STW 03/09/12	SHEET 1 OF 1