

SW2014

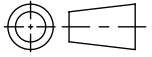

Revision level			Revision Record	Changed	Date	Approved	Date
Drawing	State	Part					
00.0	Design Release		SEE ECN# 013630	GRW	11/28/2016	KAC	11/28/2016

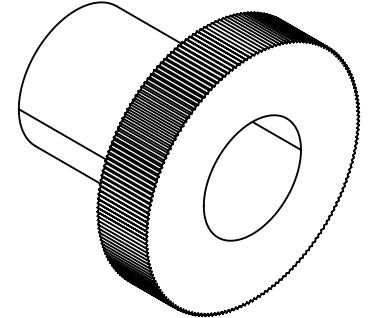
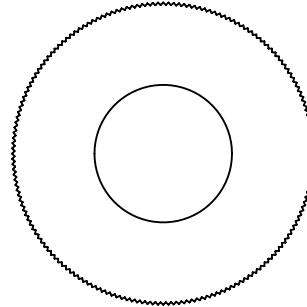
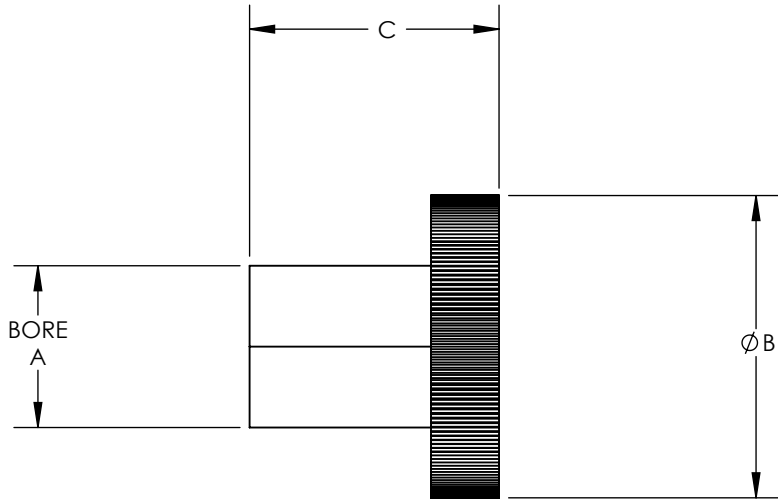

To Fit Conduit Size Ø	HellermannTyton Part Number	Manufacturer Reference Number	Through Bore Ø		Dimension					
			A		B		C		D	
			in.	mm	in.	mm	in.	mm	in.	mm
Ø10	LTP10-E	LTP10-E	0.22	5.6	0.14	3.6	0.50	12.7	0.54	13.8
Ø12	LTP12-E	LTP12-E	0.34	8.6	0.14	3.6	0.50	12.7	0.63	16.1
Ø16	LTP16-E	LTP16-E	0.42	10.7	0.18	4.5	0.47	12.0	0.79	20.0
Ø20	LTP20-E	LTP20-E	0.57	14.5	0.18	4.5	0.49	12.5	0.90	22.9
Ø25	LTP25-E	LTP25-E	0.71	18.0	0.24	6.1	0.61	15.4	1.13	28.7
Ø32	LTP32-E	LTP32-E	0.97	24.6	0.27	6.6	0.69	17.4	1.38	35.0
Ø40	LTP40-E	LTP40-E	1.29	32.7	0.32	8.1	0.78	19.9	1.77	45.0
Ø50	LTP50-E	LTP50-E	1.48	37.7	0.32	8.1	0.86	21.9	2.01	51.0
Ø63	LTP63-E	LTP63-E	1.93	49.0	0.40	10.1	0.98	24.9	2.48	63.0

- NOTES:
 1. OPERATING TEMPERATURE -58° F TO +275° F (-50° C TO +135° C)
 2. RoHS
 3. HF

Material
 NICKEL PLATED BRASS

Units: inches
 Dimension without tolerances details to:
 .xxxx = ±.0005
 .xxx = ±.005
 .xx = ±.01
 .x = ±.03
 None = ±.06
 < = ±0.5°
 Dimension Formatted in[mm]

The copyright of this drawing is reserved by HellermannTyton. It is issued on condition that it is not reproduced, copied, or disclosed to a third party, either wholly or in part, without the consent of HellermannTyton.

Drawn GRW 11/28/2016
 Approved KAC 11/28/2016
HellermannTyton
 North America
 Email: corp@htamericas.com
 Web: www.hellermann.tyton.com

Article/Type-No LTP-E SERIES
 Title **HELAGUARD METALLIC CONDUIT END CAP INSERT**
 Drawing-No PRODUCTION : Phase
16-1966-001-CSU

Scale
 Project Number PRP 16-1966
 Format AH
 Sheet 1/1