

REVISIONS					
P	LTR	DESCRIPTION	DATE	DWN	APVD
F1		NEW DRAWING PER ECO-11-019045	03APR12	KH	DR
F2		REVISED PER ECO-17-007400	30NOV2017	RS	DR

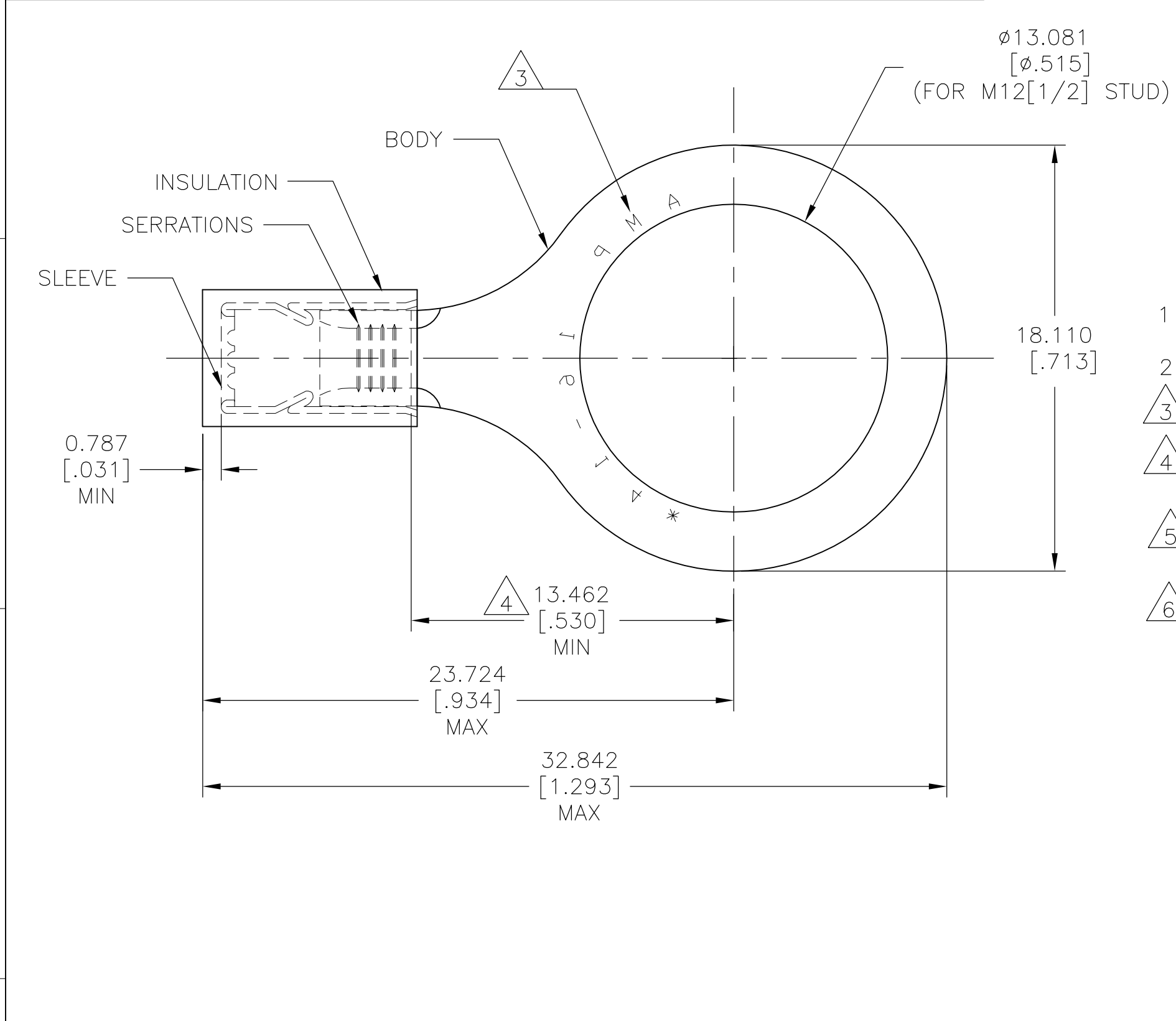

AMP WIRE RANGE	Listed FILE E13288	LR7189 Certified
16-14 AWG SOLID OR STRANDED	16-14 AWG SOLID OR STRANDED	16-14 AWG SOLID OR STRANDED

- 1 BODY MATERIAL THK: 0.787±0.051[.031±.002]
- 2 FOR WIRE INSULATION: $\phi 2.921[\phi.115]$ TO $\phi 4.318[\phi.170]$
- 3 STAMP AMP 16-14* APPROX AS SHOWN.
- 4 APPLIES FROM EDGE OF METAL WIRE BARREL TO CENTER OF STUD HOLE.
- 5 MATERIAL: BODY & SLEEVE: COPPER PER ASTM B152. INSULATION : NYLON
- 6 FINISH: BODY & SLEEVE: TIN PLATE PER ASTM B545. INSULATION: COLOR-BLUE.

1000	LOOSE PC	328849
QTY	PACKAGE TYPE	PART NO

AMP INCORPORATED
CUSTOMER SERVICE SYSTEMS

FOR ADDITIONAL PRODUCT INFORMATION OR COPIES OF DRAWINGS AND TECHNICAL DOCUMENTS
 PRODUCT INFORMATION CENTER
 1-800-522-6752

FOR APPLICATION TOOLING INFORMATION
 TOOLING ASSISTANCE CENTER
 1-800-722-1111

FOR ORDER ENTRY
 1-800-526-5142

RECOMMENDED OPERATING TEMPERATURE:
 105°C [221°F]

VOLTAGE RATING:
 300V MAX

WIRE CROSS SECTIONAL AREA RANGE:
 1.04-2.62mm² [2,050-5,180] CIR.MIL
 SOLID OR STRANDED

THIS DRAWING IS A CONTROLLED DOCUMENT.

DIMENSIONS: mm [INCHES]	TOLERANCES UNLESS OTHERWISE SPECIFIED:
	0 PLC ± -
	1 PLC ± -
	2 PLC ± -
	3 PLC ± 0.127[.005]
	4 PLC ± -
	ANGLES ± 5°
MATERIAL	FINISH
5	6

DWN KIRAN HOLAL 03APR12	TE Connectivity
CHK ROHDE DANIEL 03APR12	
APVD ROHDE DANIEL 03APR12	
NAME	
PRODUCT SPEC UL 486 A-B	WIRE TERMINAL P.I.D.G-RING TONGUE WIRE SIZE 16-14
APPLICATION SPEC 114-2157	SIZE A3
WEIGHT -	CAGE CODE 00779
CUSTOMER DRAWING	DRAWING NO C-328849
	RESTRICTED TO -
	SCALE 5:1
	SHEET 1 OF 1
	REV F2