

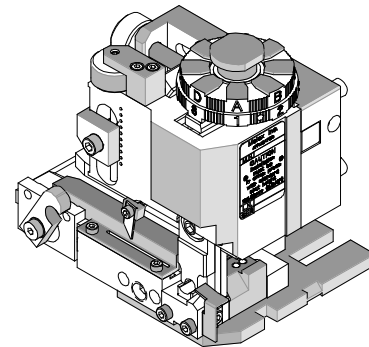

**Mini-Mac Applicator
Application Tooling
Specification Sheet
Order No. 63830-6100**



FEATURES

- % Directly adapts to most crimp presses and automatic wire processors
- % Applicator designed to industry-standard mounting and shut height of 135.80mm (5.346")
- % Conductor and insulation rings allow quick adjustment for conductor and insulation crimp height change
- % Quick set-up time; plus the crimp height, track and feed adjustments can be set without removing the applicator from the crimp press

SCOPE

Products: Panel Grounding Clip Crimp Terminal 14-16 AWG.

Terminal Series No.	Terminal Order No.	Wire Size		Insulation Diameter Max.		Strip Length	
		AWG	mm ²	mm	In.	mm	In.
42172-AA1	40-06-2014	14	2.00	3.00-3.45	.118-.136	4.75-5.54	.187-.218
42172-BB1	40-06-2015						
42172-CC1	40-06-2016						
42172-AA1	40-06-2014	16 (2)	1.30 (2)	3.00-3.45	.118-.136	4.75-5.54	.187-.218
42172-BB1	40-06-2015						
42172-CC1	40-06-2016						

DEFINITION OF TERMS

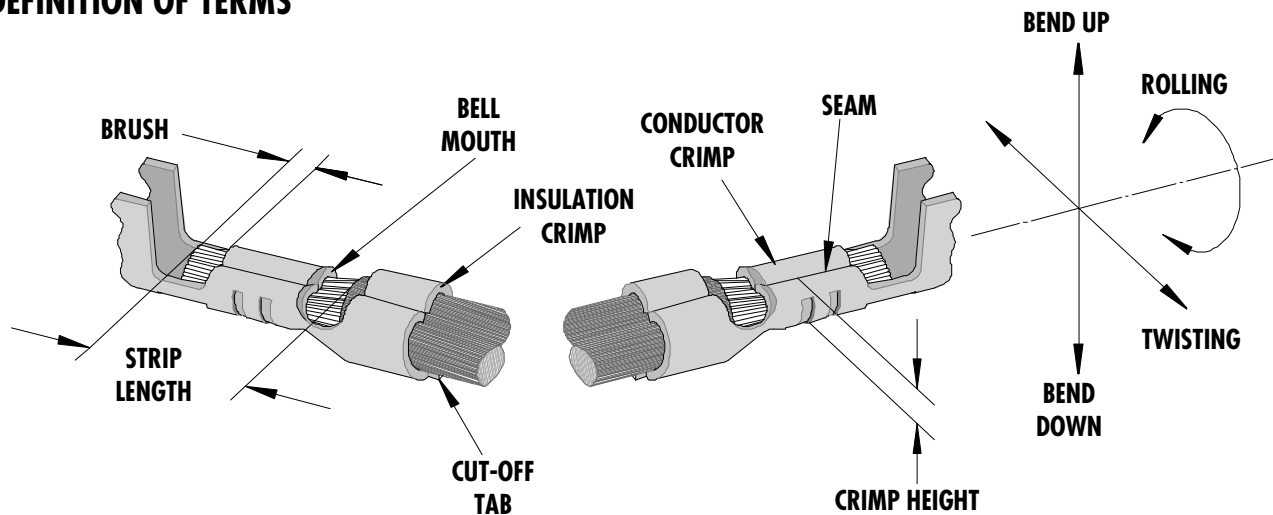

The above terminal drawing is a generic terminal representation. It is not an image of any terminal listed in the scope.

CRIMP SPECIFICATION

Terminal Series No.	Bell mouth		Cut-off Tab Max.				Conductor Brush	
			Front		Rear			
	mm	In.	mm	In.	mm	In.	mm	In.
42172-AA1	0.51-1.02	.020-.024	0.38	.015	0.25	.010	0.75-2.25	.030-.089
42172-BB1	0.51-1.02	.020-.024	0.38	.015	0.25	.010	0.75-2.25	.030-.089
42172-CC1	0.51-1.02	.020-.024	0.38	.015	0.25	.010	0.75-2.25	.030-.089

Terminal Series No.	Bend up	Bend down	Twist	Roll	Punch Width (Ref)				Seam Seam shall not be open and no wire allowed out of the crimping area
	Degree		Degree		Conductor		Insulation		
	mm	In	mm	In	mm	In	mm	In	
42172-AA1	3	3	4	8	3.20	.126	4.30	.169	
42172-BB1	3	3	4	8	3.20	.126	4.30	.169	
42172-CC1	3	3	4	8	3.20	.126	4.30	.169	

After crimping, the crimp profiles should measure the following:

Terminal Series No.	Wire Size		Conductor Crimp Height		Pull Force Min.	
	AWG	mm ²	mm	In.	N	Lb.
42172-AA1	14	2.00	2.16-2.21	.085-.087	4.00.0	90.0
42172-AA1	16 (2)	1.30 (2)	2.21-2.26	.087-.089	266.7	60.0
42172-BB1	14	2.00	2.16-2.21	.085-.087	4.00.0	90.0
42172 BB1	16 (2)	1.30 (2)	2.21-2.26	.087-.089	266.7	60.0
42172 CC1	14	2.00	2.16-2.21	.085-.087	4.00.0	90.0
42172-CC1	16 (2)	1.30 (2)	2.21-2.26	.087-.089	266.7	60.0

Pull Force should be measured with no influence from the insulation crimp.
The above specifications are guidelines to an optimum crimp.

PARTS LIST

Mini-Mac Applicator 63830-6100				
Item	Order No	Engineering No.	Description	Quantity
Perishable Tooling				
	63830-6170	63830-6170	Tool Kit (All "Y" Items)	REF
1	63830-6001	63830-6001	Conductor Punch	1 Y
2	63445-3180	63445-3180	Conductor Anvil	1 Y
3	63830-6002	63830-6002	Insulation Punch	1 Y
4	63445-4322	63445-4322	Insulation Anvil	1 Y
5	63443-0048	63443-0048	Cut-Off Plunger	1 Y
6	63443-0049	63443-0049	Front Cut-off Plunger Retainer	1 Y
Other Components				
7	11-18-4612	60743A110	Rear Cover Riser	1
8	11-18-4940	60743C122	Front Cover	1
9	63443-0009	63443-0009	Scrap Chute	1
10	63443-0021	63443-0021	Lower Tooling Key	1
11	63443-0050	63443-0050	Tooling Washer	1
12	63443-2501	63443-2501	Anvil Mount	1
13	63700-0539	63700-0539	Cut-Off Plunger Spring	1
14	63830-3006	63830-3006	Front Plunger Striker	1
15	63830-6003	63830-6003	Wire Stop	1
Frame				
16	63800-4300	63800-4300	Mini-Mac Applicator Frame	1
17	11-18-4822	60800A118	Conductor Adjusting Cam	1
Hardware				
18	N/A	N/A	M3 by 6 Long SHCS	2**
19	N/A	N/A	M4 by 6 Long SHCS	1**
20	N/A	N/A	M4 by 12 Long BHCS	2**
21	N/A	N/A	M4 by 50 Long SHCS	2**
22	N/A	N/A	M5 by 12 Long SHCS	1**
23	N/A	N/A	M8 by 25 Long BHCS	1**
24	N/A	N/A	3mm by 6 Long Roll Pin	1**
** Available from an industrial supply company such as MSC (1-800-645-7270).				

Assembly Drawing

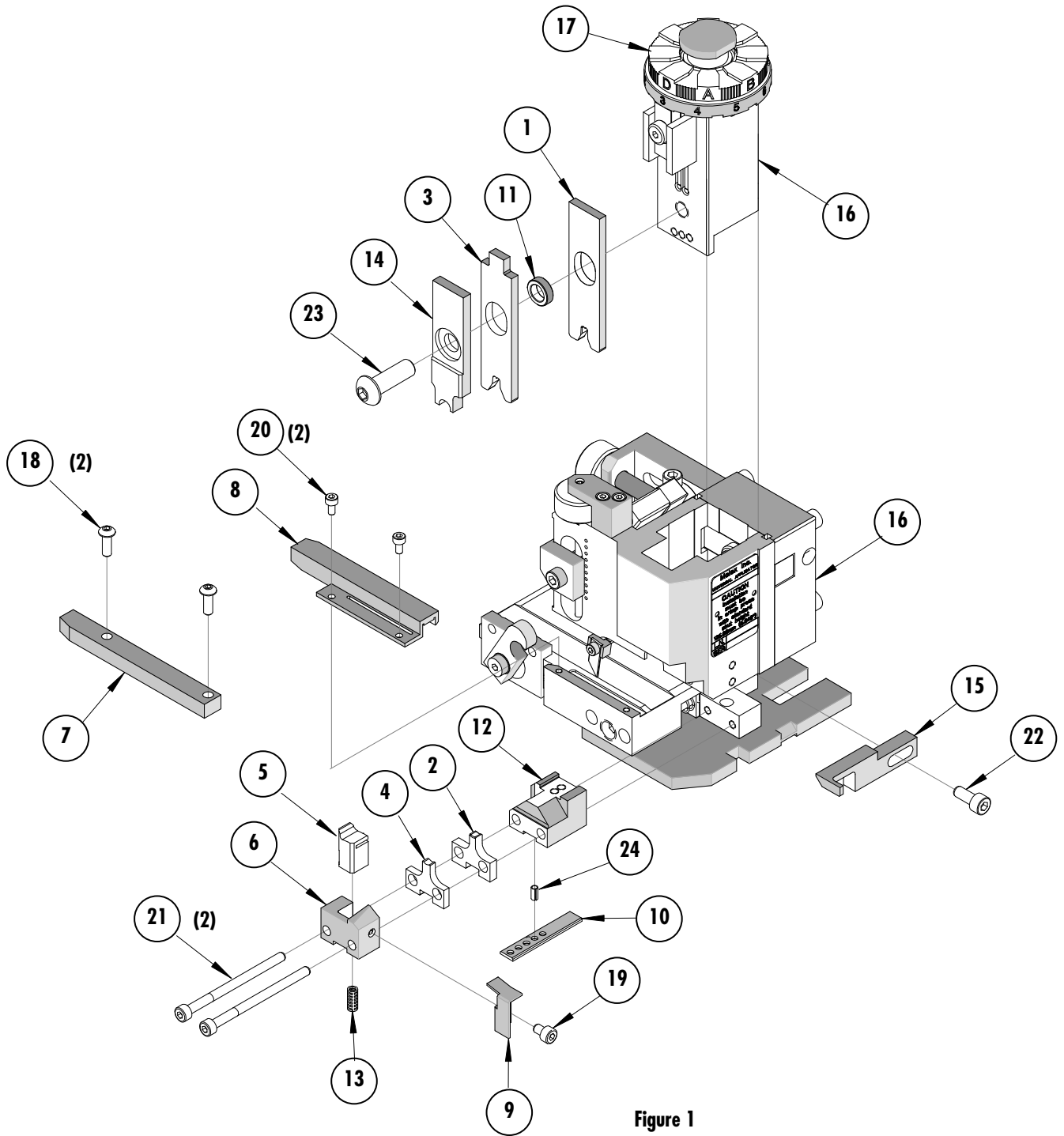

Figure 1

NOTES

1. Molex recommends an extra perishable tooling kit be maintained at your facility.
2. Verify tooling alignment by manually cycling the press with applicator before crimping under power. Check that all screws are tight.
3. Slugs, terminals, dirt, and oil should be kept clear of work area.
4. Wear safety glasses at all times.
5. For recommended maintenance refer to the Mini-Mac Applicator Manual (Document no. 63880-0000).

CAUTION: This applicator should only be used in a press with a shut height of 135.80 mm (5.346"). Tooling damage could result at a lower setting.

CAUTION: To prevent injury, never operate this applicator without the guards supplied with the press or wire-processing machine in place. Reference the press or wire processing manufacturer's instruction manual.

CAUTION: Molex crimp specifications are valid only when used with Molex terminals, applicators and tooling.

Contact Information

For more information on Molex application tooling please contact Molex at 1-800-786-6539.

Americas Headquarters

Lisle, Illinois 60532 U.S.A.
1-800-78MOLEX
amerinfo@molex.com

Far East North Headquarters

Yamato, Kanagawa, Japan
81-462-65-2324
feninfo@molex.com

Far East South Headquarters

Jurong, Singapore
65-6-268-6868
fesinfo@molex.com

European Headquarters

Munich, Germany
49-89-413092-0
eurinfo@molex.com

Corporate Headquarters

2222 Wellington Ct.
Lisle, IL 60532 U.S.A.
630-969-4550
Fax: 630-969-1352

Visit our Web site at <http://www.molex.com>