

THIS DRAWING IS UNPUBLISHED. RELEASED FOR PUBLICATION
 © COPYRIGHT - By - ALL RIGHTS RESERVED.

| LOC | DIST | REVISIONS | | | |
|-----|------|---------------------------|-----------|-----|------|
| P | LTR | DESCRIPTION | DATE | DWN | APVD |
| AF | 50 | | | | |
| | D2 | REVISED PER ECR-19-013909 | 30SEP2019 | PC | MB |

IDENTIFICATION NUMBER 10 FOR
MAGNET WIRE RANGE

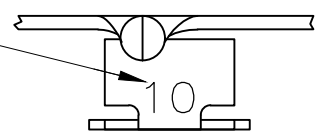

- 1 CONTINUOUS STRIP ON REELS WITH TERMINALS LOCATED ON 5.59 [.220] CENTERS.
- 2 SLOT TERMINATES EITHER SINGLE OR DOUBLE MAGNET WIRES OF THE SAME TYPE AND SIZE, COPPER RANGE IS 0.36-0.57mm [#27-#23 AWG]. ALUMINIUM RANGE IS 0.51-0.64mm [#24-#22] AWG. ALUMINIUM WIRE RANGE APPLIES FOR POST TIN PLATED PART NUMBERS ONLY.
- 3 TIN PLATE PER MIL-T-10727

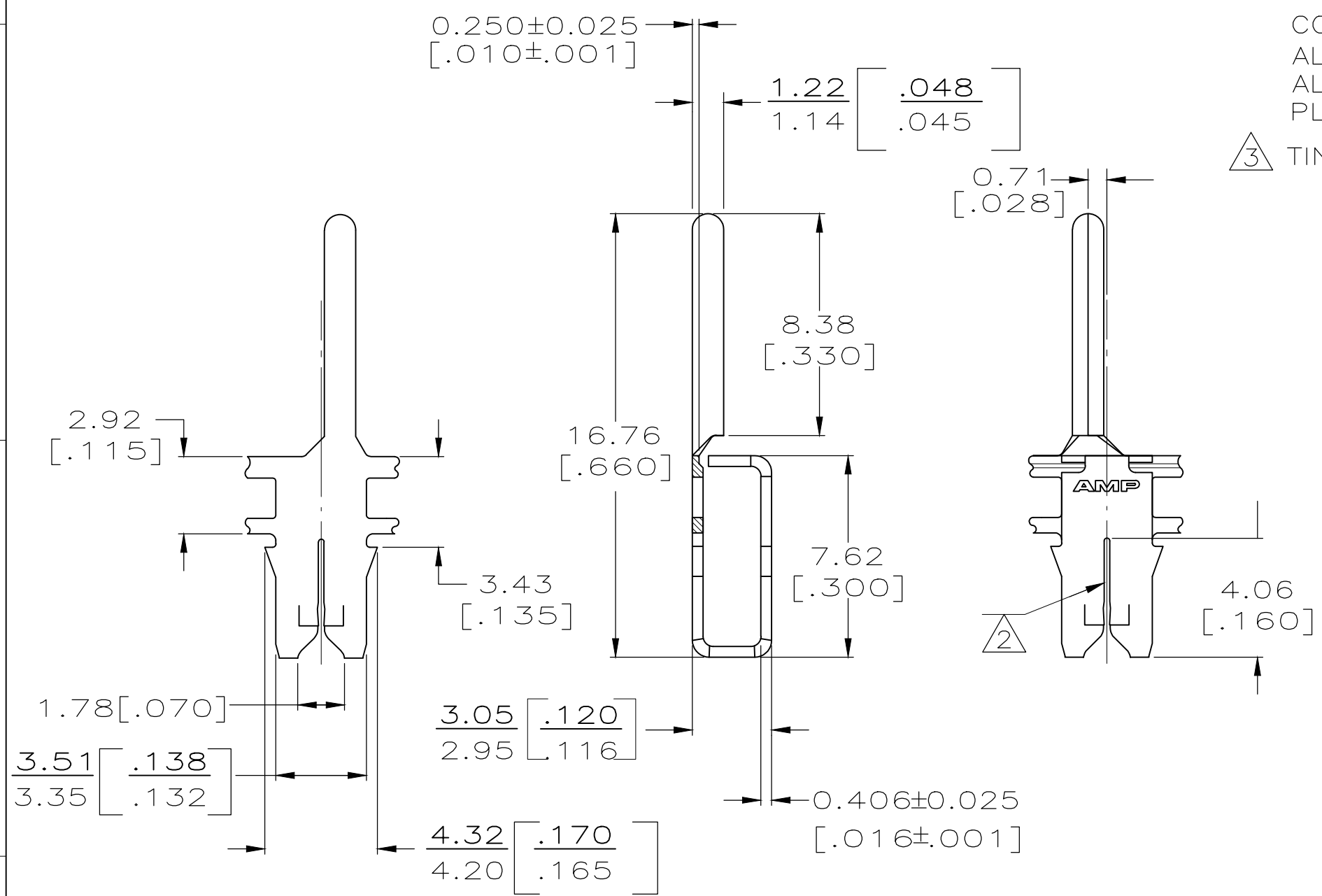

63570-1

| | | | | | |
|--|--|-------------------------------|--------------------------|--------------------|-----------------------|
| THIS DRAWING IS A CONTROLLED DOCUMENT. | | DWN D.K. SCHRUM 2/1/90 | TE Connectivity | | |
| DIMENSIONS: INCHES | | CHK M.S. FEHER 2/2/90 | | | |
| TOLERANCES UNLESS OTHERWISE SPECIFIED: | | APVD D.F. DECKER 2/2/90 | PRODUCT SPEC 108-2012 | | |
| 0 PLC ± - 1 PLC ± - 2 PLC ± 0.15[.006] 3 PLC ± - 4 PLC ± - ANGLES ± - | | APPLICATION SPEC 114-2046 | SIZE A3 | CAGE CODE 00779 | DRAWING NO C-63570 |
| MATERIAL BRASS | | FINISH 3 | WEIGHT - | RESTRICTED TO - | |
| CUSTOMER DRAWING | | | SCALE 5:1 | SHEET 1 OF 1 | REV D2 |