

used for: D-SUB COMBINATION

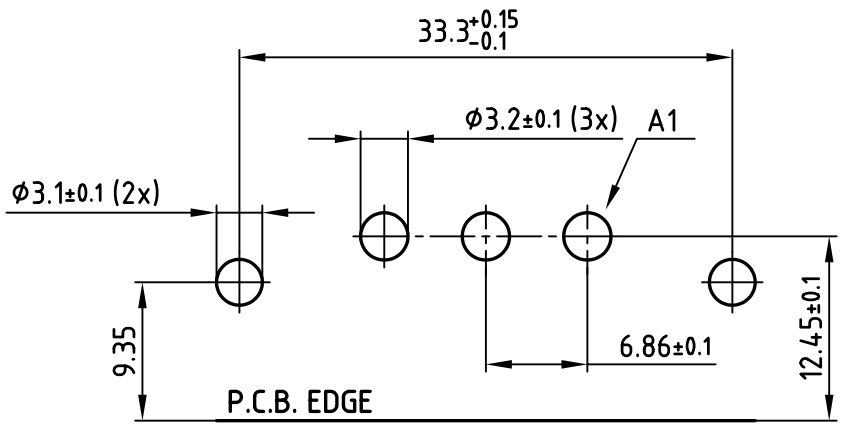

P.C.B. HOLE DRILLINGS

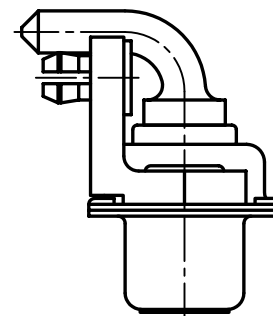
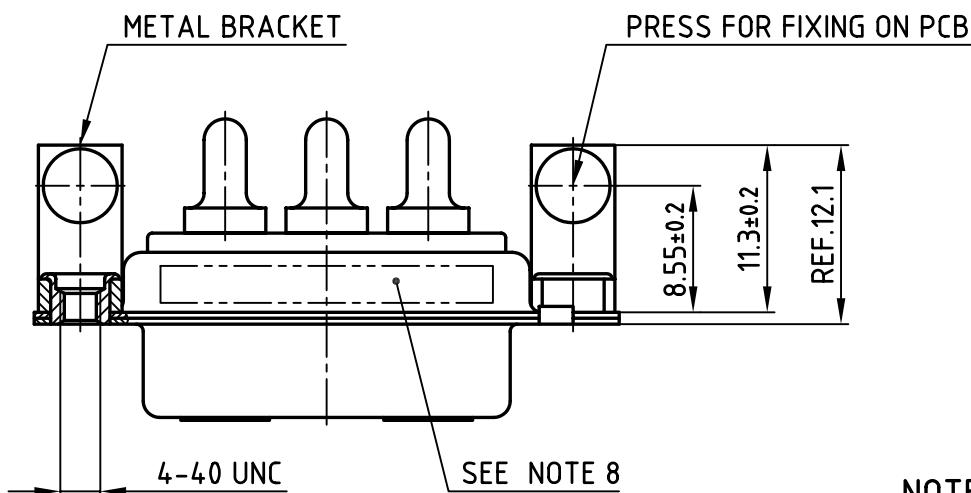
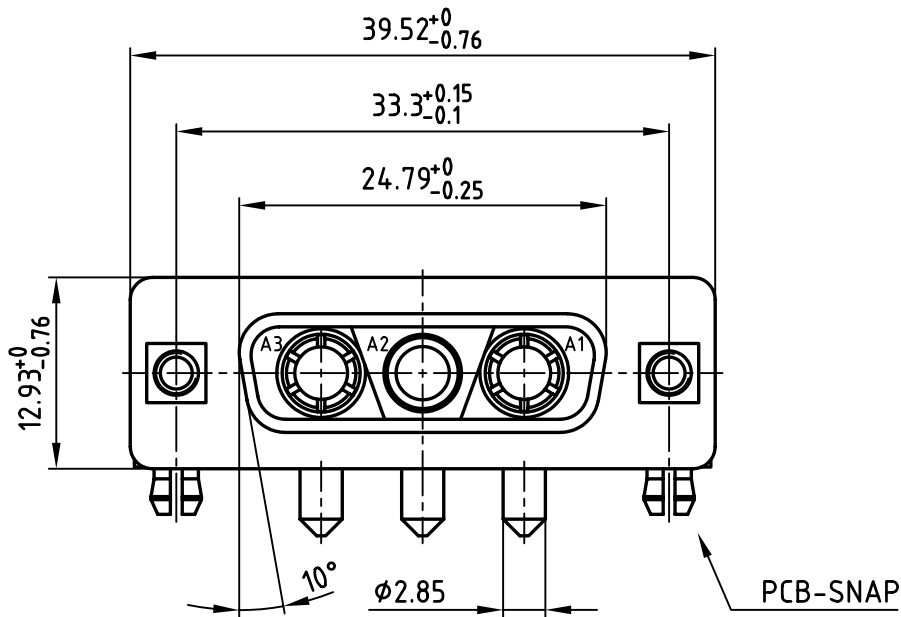
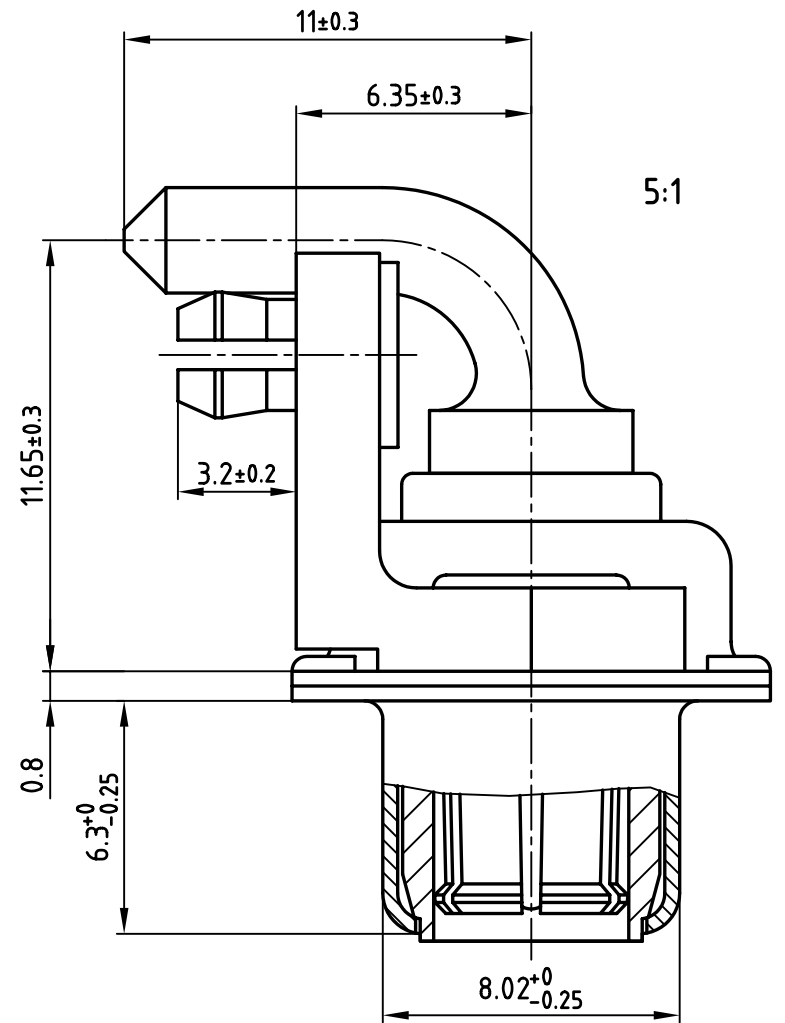

NOTES:

- METALSHELLS: STEEL; min. 320µ" TIN
- INSULATORS: PBT GF UL 94 V-0, GREEN
- HIGH POWER CONTACTS 20A: COPPER ALLOY
PLATING: 30µ" HARD GOLD OVER min. 50µ" NICKEL
FEMALE CONTACT ON POS. A1 + A3
MALE CONTACT ON POS. A2
- METAL BRACKET: DIE CASTING; min. 320µ" TIN over 80µ" NICKEL
- THREADED INSERT: COPPER ALLOY; min. 200µ" TIN over 80µ" NICKEL
- PCB-SNAP: COPPER ALLOY; min. 200µ" TIN over 80µ" NICKEL
PCB-HOLE: $\phi 3.1 \pm 0.1$; PCB THICKNESS 1.6mm
- MAXIMUM TORQUE VALUE FOR THREAD: 6" LBS
- CONNECTOR IS PART MARKED: 303W3CSXX56N40X CONEC ABC



APPROVAL # FREIGABE # DEBLOCAGE # AUTORIZACION # APPROVAL	
CUSTOMER APPROVAL DATE:	
NAME:	TITLE:
COMPANY NAME:	
APPROVAL # FREIGABE # DEBLOCAGE # AUTORIZACION # APPROVAL	

THIS DRAWING MAY NOT BE COPIED OR REPRODUCED IN ANY WAY, AND MAY NOT BE PASSED ON TO A THIRD PARTY WITHOUT WRITTEN PERMISSION. OWNERSHIP AND COPYRIGHT OF CONEC GmbH			
DO NOT ALTER CAD DRAWING BY HAND			
rev.	description	date	name
a	Origin		

tolerance	dim. in mm	scale:	2:1 (5:1)
		material:	SEE NOTES
2006	date	name	title: D-SUB COMBINATION FEMALE 90° 3W3CS with threaded insert, metal bracket and clip
drawn	09.02.	Lehmenkühler	
appd.	09.02.	Mickenbecker	
norm			dwg no: AutoCAD 2004 DIN-A 3 sh:1/1
d-old			
CONEC		part no: 303W3CSXX56N40X	