

FIGURE 1

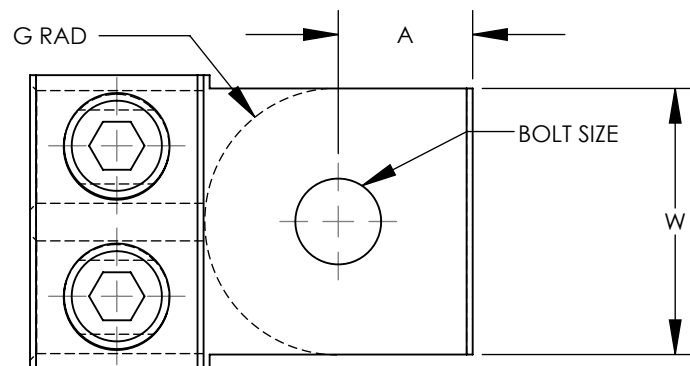
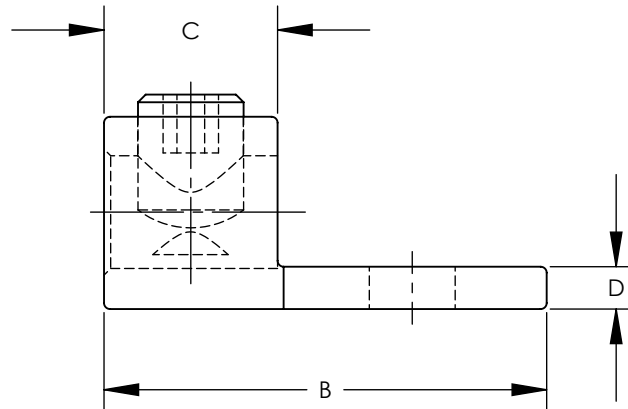
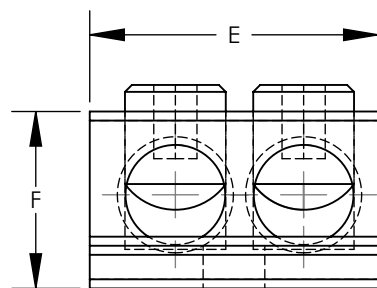
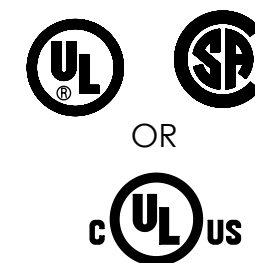

FIGURE 2

NOTES:

1. MATERIAL:
BODY - ALUMINUM, TIN PLATED
SCREW - ALUMINUM, TIN PLATED
2. UL LISTED, CSA CERTIFIED, OR cULus FOR USE UP TO 600V & TEMPERATURE RATED 90°C (AL9CU)
3. DUAL RATED FOR USE WITH COPPER OR ALUMINUM STRANDED CODE CONDUCTOR
4. THESE PARTS ARE RoHS COMPLIANT
5. USE OF OXIDE INHIBITING JOINT COMPOUND LIKE PANDUIT CMP-100 RECOMMENDED FOR PAD TO PAD AND CONDUCTOR SURFACES
6. SEE PACKAGING LABEL FOR TIGHTENING TORQUE INFORMATION
7. PKG QTY:
6 = 6



PART NUMBER	FIGURE	WIRE RANGE COPPER/ALUMINUM	WIRE STRIP LENGTH - IN [mm]	STUD SIZE IN	DIMENSIONS - IN [mm]								HEX KEY*	AGENCY
					A ± .02 [.5]	B ± .05 [1.3]	C ± .03 [.8]	D ± .03 [.8]	E ± .04 [1]	F ± .03 [.8]	G ± .02 [.5]	W ± .05 [1.3]		
LAM2A1/0-14-6Y	1	14 AWG - 1/0 AWG	.62 [15.7]	1/4	0.43 [10.8]	1.48 [37.5]	0.63 [15.9]	0.19 [4.7]	1.13 [28.7]	0.77 [19.5]	0.42 [10.7]	N/A	SLOTTED	cULus
LAM2A2/0-14-6Y	1	14 AWG - 2/0 AWG	.62 [15.7]	1/4	0.43 [10.8]	1.46 [37.2]	.63 [15.9]	0.19 [4.7]	1.25 [31.8]	0.77 [19.5]	0.42 [10.7]	N/A	3/16	cULus
LAM2A250-38-6Y	2	6 AWG - 250 kcmil	1.00 [25.4]	3/8	0.51 [13.0]	2.58 [65.5]	1.01 [25.6]	0.26 [6.5]	1.64 [41.6]	1.19 [30.3]	1.05 [26.7]	1.50 [38.0]	5/16	cULus
LAM2A350-12-6Y	2	6 AWG - 350 kcmil	1.13 [28.6]	1/2	0.88 [22.2]	2.88 [73.2]	1.13 [28.7]	0.28 [7]	1.91 [48.4]	1.25 [31.8]	0.86 [21.8]	1.73 [44.0]	5/16	cULus
LAM2A600-12-6Y	2	2 AWG - 600 kcmil	1.38 [34.9]	1/2	0.63 [16.0]	3.19 [81.0]	1.38 [34.9]	0.44 [11.2]	2.38 [60.5]	1.56 [39.6]	1.19 [30.2]	2.00 [50.8]	3/8	UL & CSA
LAM2A1000-58-6Y	1	500 kcmil - 1000 kcmil	1.63 [41.4]	5/8	0.88 [22.2]	3.50 [88.9]	1.63 [41.4]	0.50 [12.7]	3.50 [88.9]	1.94 [49.3]	1.00 [25.4]	N/A	3/8	UL & CSA

* HEX SIZE MAY DIFFER FROM CHART. DIFFERENCE IN SIZE WILL NOT AFFECT FIT, FORM, OR FUNCTION OF PART

09	1/2020	JHNU	RGB	RGB	REVISED B DIM FOR LAM2A1/0-14-6Y: 1.48 [37.5] WAS 1.47 [37.3] REVISED C DIM FOR LAM2A1/0-14-6Y: .63 [15.9] WAS .62 [15.7] REVISED D DIM FOR LAM2A1/0-14-6Y: .19 [4.7] WAS .19 [4.8] REVISED E DIM FOR LAM2A1/0-14-6Y: 1.13 [28.7] WAS 1.13 [28.7] REVISED F DIM FOR LAM2A1/0-14-6Y: .77 [19.5] WAS .78 [19.9] REVISED B DIM FOR LAM2A2/0-14-6Y: 1.46 [37.2] WAS 1.47 [37.3] REVISED C DIM FOR LAM2A2/0-14-6Y: .63 [15.9] WAS .62 [15.7] REVISED D DIM FOR LAM2A2/0-14-6Y: .19 [4.7] WAS .19 [4.8] REVISED E DIM FOR LAM2A2/0-14-6Y: 1.25 [31.8] WAS 1.20 [30.6] REVISED F DIM FOR LAM2A2/0-14-6Y: .77 [19.5] WAS .78 [19.9] REVISED B DIM FOR LAM2A250-38-6Y: 2.58 [65.5] WAS 2.56 [65.1] REVISED C DIM FOR LAM2A250-38-6Y: 1.01 [25.6] WAS 1.00 [25.4] REVISED D DIM FOR LAM2A250-38-6Y: .26 [6.5] WAS .25 [6.4] REVISED E DIM FOR LAM2A250-38-6Y: 1.64 [41.6] WAS 1.64 [41.7] REVISED F DIM FOR LAM2A250-38-6Y: 1.19 [30.3] WAS 1.19 [30.2]	057109	TITLE	LAM2A SERIES ALUMINUM MECHANICAL LUGS CUSTOMER DRAWING					
							ITEM REVISION NAME	10N006AT/10					
							DATASET FILE NAME	10N006AT-NC/10.SLDDRW					
							UNLESS OTHERWISE SPECIFIED, DIMENSIONAL TOLERANCES ARE: IN [mm]			MATERIAL	SEE NOTES		
.X ± .XXX ± .XX ± ANGLES ±				THIRD ANGLE PROJECTION									
REV	DATE	BY	CHK	APR	DESCRIPTION	ECN	DRAWN BY	DATE	CHK	SCALE	DRAWING NUMBER	SHEET 1 OF 1	SIZE
							JHNU	2/06	JHNU	NONE	10N006AT-NC		B