

Solder Instruction

1. Cable should be prepared for soldering. The cable/wires must be pretinned.
2. Insert cable/wire into solder cup.
3. Operate the soldering iron at 350°C, 100 Watt max. and use a pencil tip.
4. Put tip to wire in solder cup.
5. After 1 second bring in solder.
6. Heat for 5 seconds longer. Do not heat contact more than 6 seconds in total.
7. Remove soldering iron.
8. Wait until solder gets rigid again.
9. Do not solder adjacent contacts consecutively, alternate position within the connector to minimize heat build up.

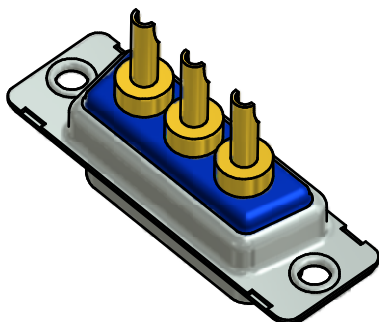
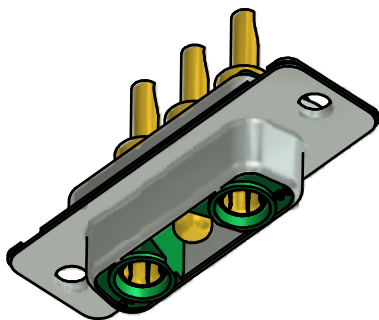
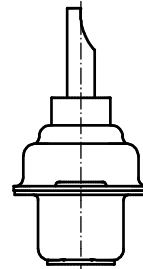
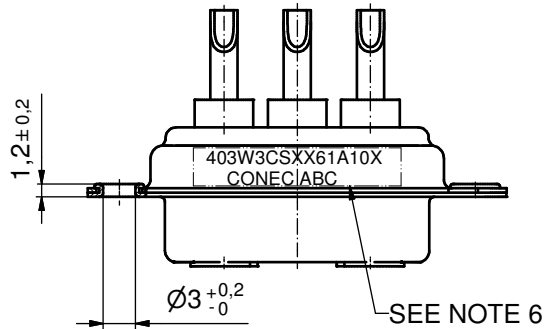
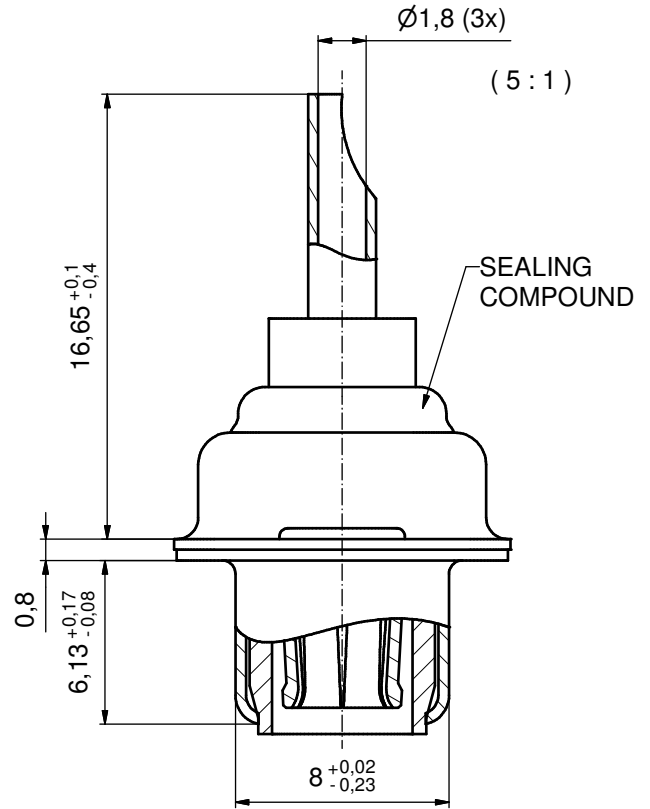
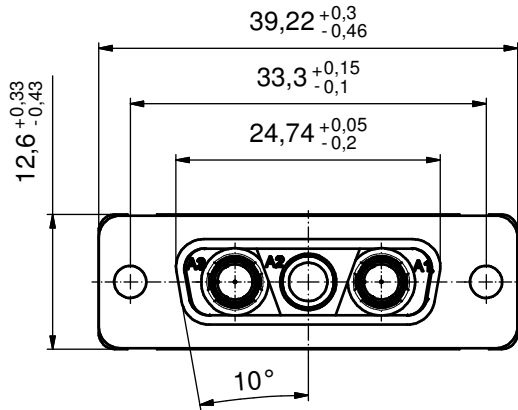

Directive 2002/95/EC RoHS compliant

NOTES:

1. METALSHELLS: COPPER ALLOY; min. 315µin TIN over 40-80µin NICKEL
2. INSULATOR: PBT GF UL 94 V-0, GREEN
3. HIGH POWER CONTACTS 10A: COPPER ALLOY
PLATING MATING AREA: GOLD FLASH over NICKEL
PLATING TERMINATION SIDE: GOLD FLASH over NICKEL
SOLDER CUP ACCEPTS CABLE AWG 16-20
4. SEALING COMPOUND: PUR; BLUE
5. FEMALE CONTACTS ON POS. A1 + A3; MALE CONTACT ON POS. A2
6. CONNECTOR IS PART MARKED: 403W3CSXX61A10X CONEC|ABC

THIS DRAWING MAY NOT BE COPIED OR REPRODUCED IN ANY WAY, AND MAY NOT BE PASSED ON TO A THIRD PARTY WITHOUT WRITTEN PERMISSION. OWNERSHIP AND COPYRIGHT OF CONEC GmbH DO NOT ALTER CAD DRAWING BY HAND	tolerance		dim. in mm		scale:	2:1 (5:1)	
						material:	SEE NOTES
	date	name		title:			
	drawn	22.06.12	Henneboel		D-SUB COMBINATION FEMALE		
	appd.	22.06.12	Fischer		3W3CS		
	norm	for installation into water resistant hood					
d-old	dwg no:					DIN-A3	
a	Original				15K1A1062		
rev.	description				date	name	part no:
						sh: 1	