

1. THIS PLUG WILL MATE WITH ANY RECEPTACLE CONNECTOR WITH THE SAME INSERT ARRANGEMENT AS DEFINED BY MS18277-1.
  2. MAXIMUM WIRE INSULATION USED WITH THIS PLUG IS .072 [1.83] DIA.
  3. Be-Cu RETENTION CLIPS ARE INCLUDED IN INSERTS.
  4. UL/CSA DESIGNATION STAMPED IN THIS AREA, OPTIONAL.
  5. RESTRICTED TO CAE ELECTRONIC ONLY.
  6. THESE CONNECTORS ARE QUALIFIED TO GODDARD SPACE FLIGHT CENTER SPECIFICATION S-311-P-4.
  7. CONTACT NOT INCLUDED - SHOWN FOR DIMENSIONAL REFERENCE ONLY.
8. FAR SIDE REFERS TO WIDE SIDE OF KEYSTONE.

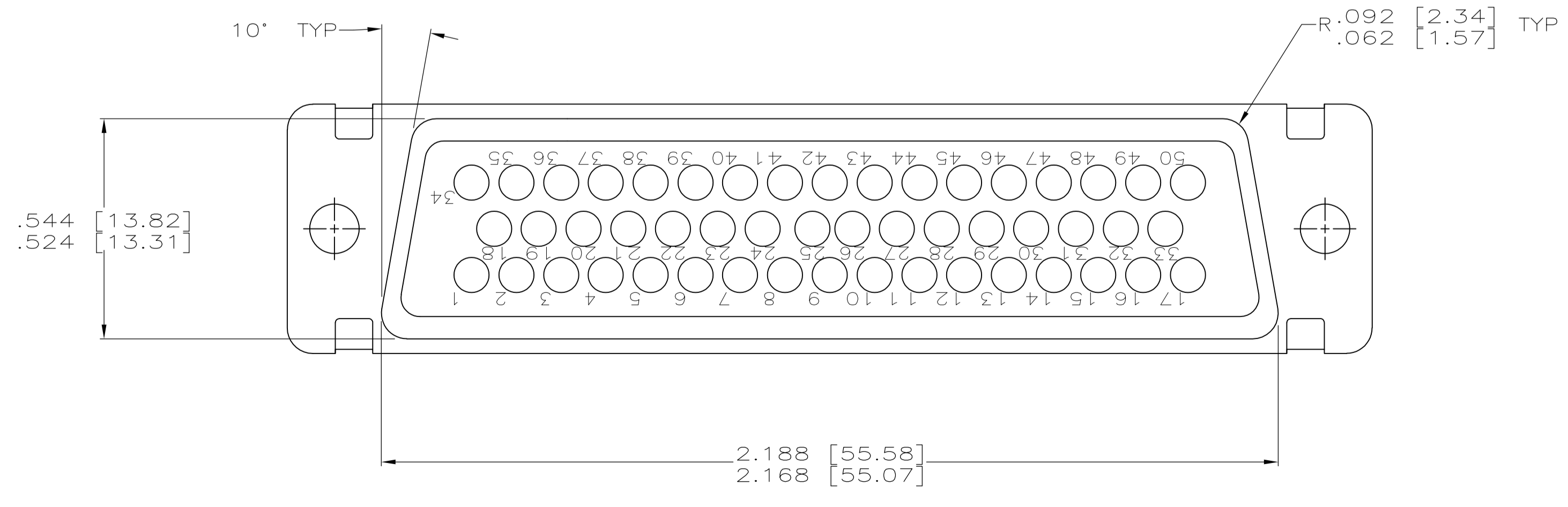
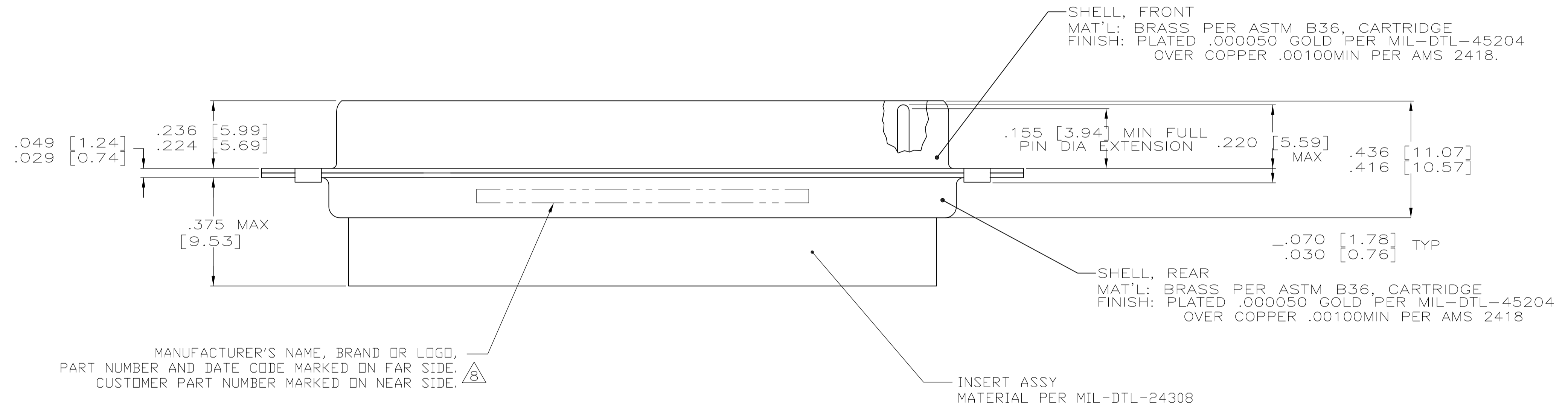

5/6	.120 [3.05]	1A01-031PHA	206804-5	206804-5
5/6	.120 [3.05]	311P409-5P-B-12	206804-2	206804-4
	.154 [3.91]	N/A	206804-3	206804-3
6	.120 [3.05]	311P409-5P-B-12	206804-2	206804-2
6	.154 [3.91]	311P409-5P-B-15	206804-1	206804-1
REMARKS	DIA A	CUSTOMER P/N ON CONNECTOR	MFG P/N ON CONNECTOR	MFG P/N

THIS DRAWING IS A CONTROLLED DOCUMENT.

DIMENSIONS: INCHES	TOLERANCES UNLESS OTHERWISE SPECIFIED:	DRAWING NO	REV
0. PLC ± .005	1. PLC ± .005	12-23-92	1
2. PLC ± .005	3. PLC ± .005	12-24-92	1
4. PLC ± .005	ANGLES ± .005		

MATERIAL: SEE CALLOUTS. FINISH: SEE CALLOUTS.

WEIGHT: —. SCALE: 4:1. SHEET: 1 OF 1. REV: —.

CUSTOMER DRAWING. SIZE: A1. CAGE CODE: 00779. DRAWING NO: 206804.

**STE** TE Connectivity

NAME: AMPLIMITE NONMAGNETIC PLUG ASSY WITHOUT SIZE 20 CRIMP TYPE PIN CONTACTS, SERIES 109.

PRODUCT SPEC: MIL-C-24308