

REV	ECN	DESCRIPTION	BY	DATE	APPROVED
A	JLIU-2211523	RELEASE TO PRODUCTION	J.LIU	11/15/2022	J.LIU

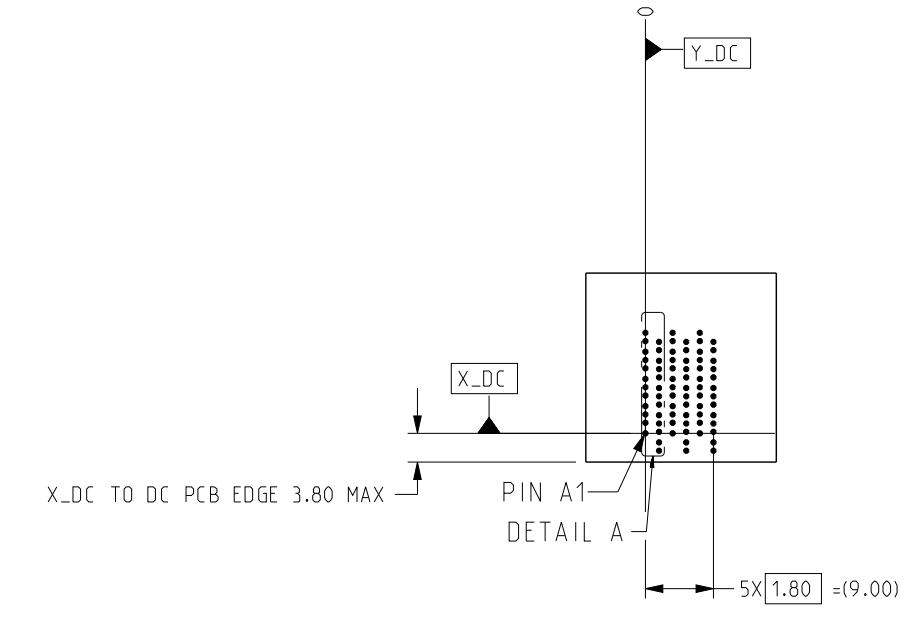

FRONT VIEW - DC HOLE PATTERN ONLY, CONNECTOR SIDE
REFERENCED FROM LEFT MOST SIGNAL COLUMN, ALL DIMENSIONS BASIC

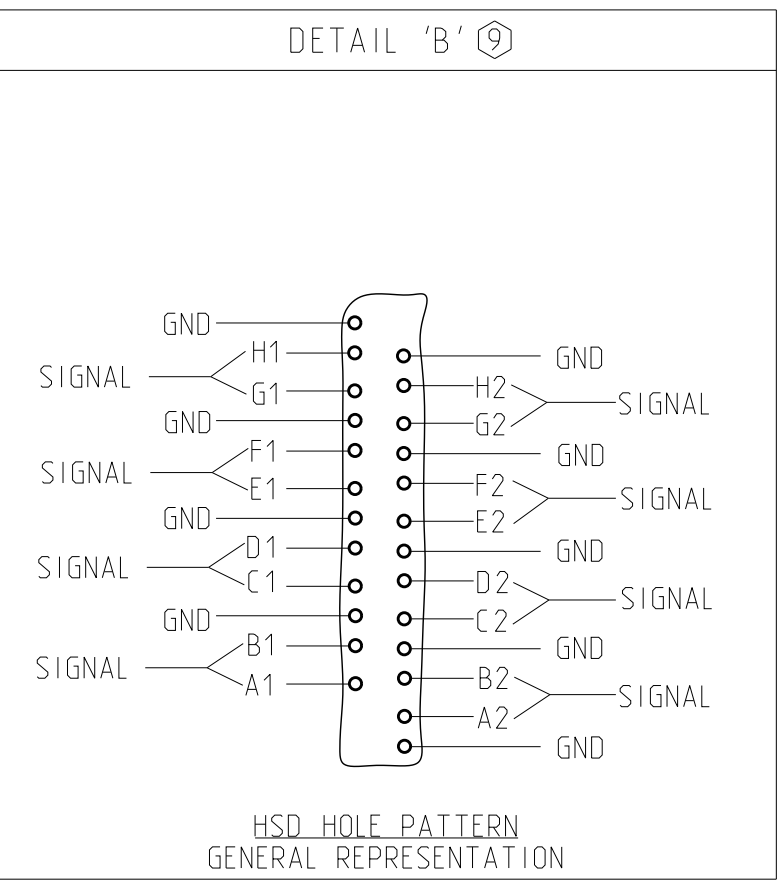
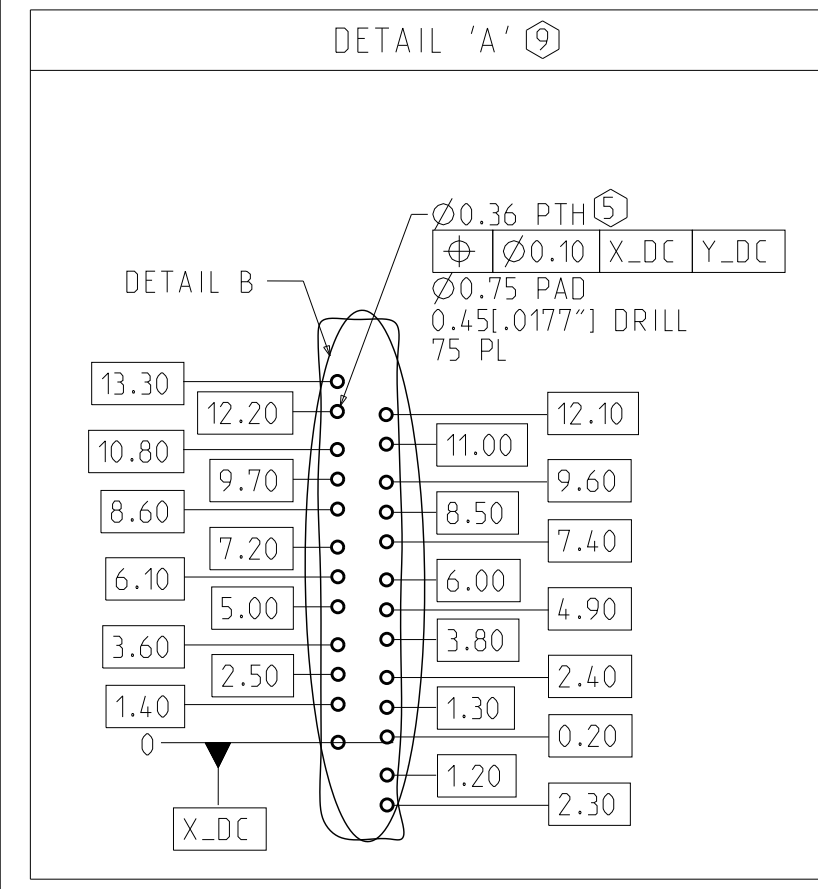
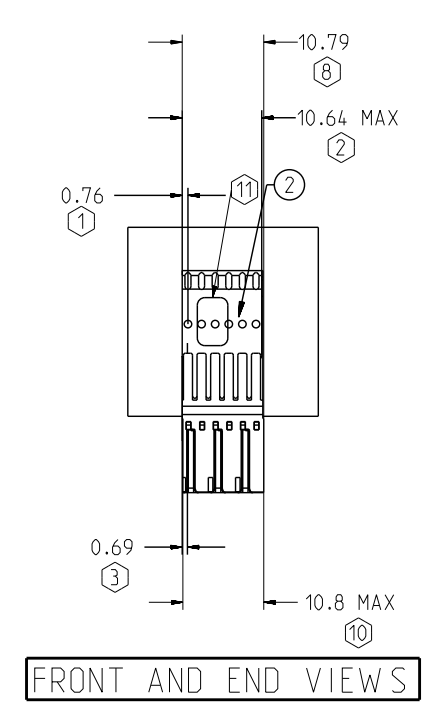

FRONT AND END VIEWS

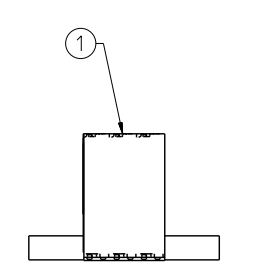
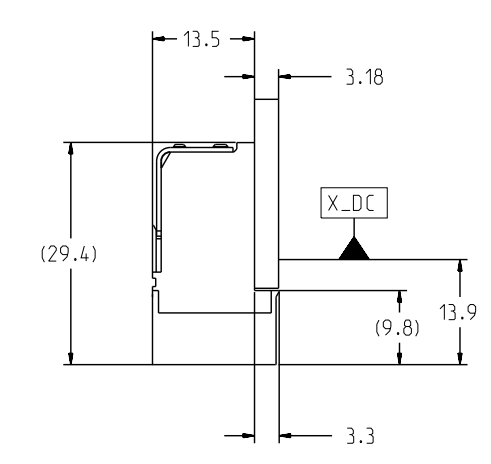

BOTTOM VIEW
MODULE LOCATIONS FROM LEFT END OF PLASTIC

NOTES:

- ① DISTANCE FROM FIRST STIFFENER PILOT HOLE TO LEFT END OF STIFFENER.
- ② TOTAL LENGTH OF STIFFENER.
- ③ DISTANCE FROM CENTERLINE OF 1ST COLUMN OF SIGNAL PLATED THRU HOLES TO LEFT EDGE OF STIFFENER.
- ④ MOUNTING SCREWS AND JOINER MODULES (IF PRESENT) TO BE BAGGED WITH EACH CONNECTOR ASSEMBLY.
- ⑤ STATED PAD SIZE MAY REQUIRE FILLETING. SEE TB-2237 FOR ROUTING, HOLE WALL PLATING THICKNESS AND FINISHED HOLE SIZE.
- ⑥ NA.
- ⑦ REFER TO TB-2235 FOR XCede HD PRODUCT SPECIFICATIONS.
- ⑧ OVERALL CONNECTOR LENGTH.
- ⑨ DETAIL VIEWS ARE NOT TO SCALE. DO NOT SCALE DRAWING.
- ⑩ FRONT HOUSING WIDTH. CONNECTORS CAN BE USED IN STACKABLE APPLICATION.
- ⑪ CONNECTOR IS LASER MARKED WITH MANUFACTURING INFORMATION.
- ⑫ REFER TO DRAWING C-527-4133-000 FOR MARKING REQUIREMENTS AND DETAILS.

TABLE 1: PARTS LIST

ITEM	PART NUMBER	DESCRIPTION	QTY
1	922-401C-D3H	XCede HD 4PAIR HSD MOD w/ ORGANIZER, 6POS, 85OHMS, BIFURCATED, .0177" DRILL, NANO NI, STD GOLD	1
2	617-0450-010	XCede HD 4PAIR STIFFENER	1

NOTE: SEE FRONT VIEW FOR STIFFENER LENGTH.

CUSTOMER: DISTRIBUTOR / XHD 4PAIR X 6. HSD 85OHMS

TOLERANCES	DESIGN	DATE	DESIGNER
0.0	±0.25	10/12/2022	J.LIU
0.00	±0.13	10/12/2022	AUTO GENERATED
0.000	± -	10/12/2022	J.LIU
ANGLES	± 3°	11/15/2022	J.LIU

Amphenol TCS A Division of Amphenol Corporation 200 Innovative Way, Nashua, NH 03062 803.879.3000	
TITLE	XCede HD DAUGHTERCARD ASSEMBLY 4 PAIR CONNECTOR, LEADFREE
PART NO.	JX410-51602
DRAWING NO.	C-JX410-51602
CRED FILES	JX410-51602.ASM JX410-51602.DRW
SIZE	D
SCALE	1/1
SHEET	1 OF 2

INTERPRET PER ANSI Y14.5
CODE IDENT 31413

CUSTOMER USE
DRAWING

REV	ECN	DESCRIPTION	BY	DATE	APPROVED
		SEE SHEET 1			

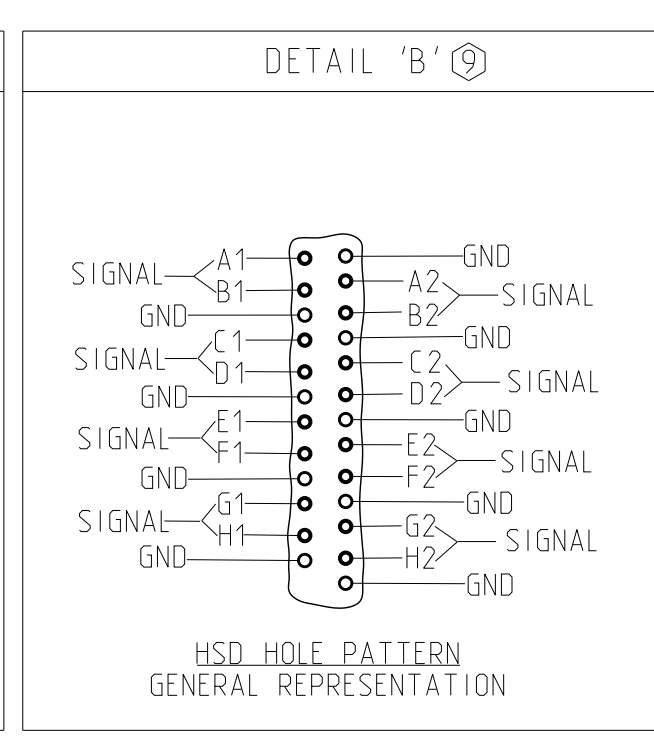
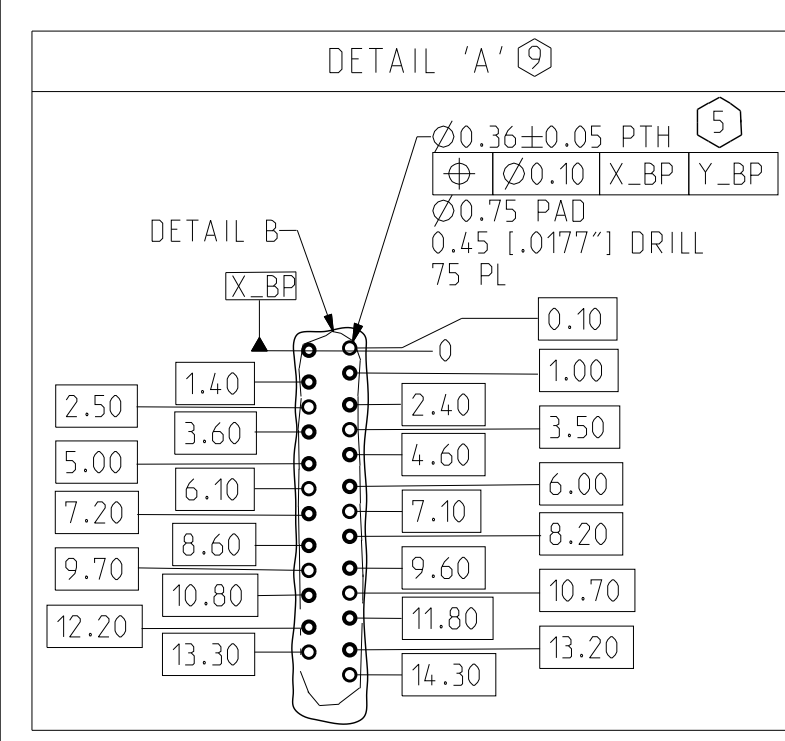

FOR REFERENCE ONLY; FOR SPECIFIC DETAILS, SEE C-USE DRAWINGS FOR BACKPLANE MODULES IN TABLE 2
 BACKPLANE COMPONENTS MUST BE PURCHASED SEPARATELY AND MAY DIFFER FROM EXAMPLE SHOWN

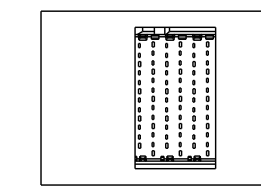
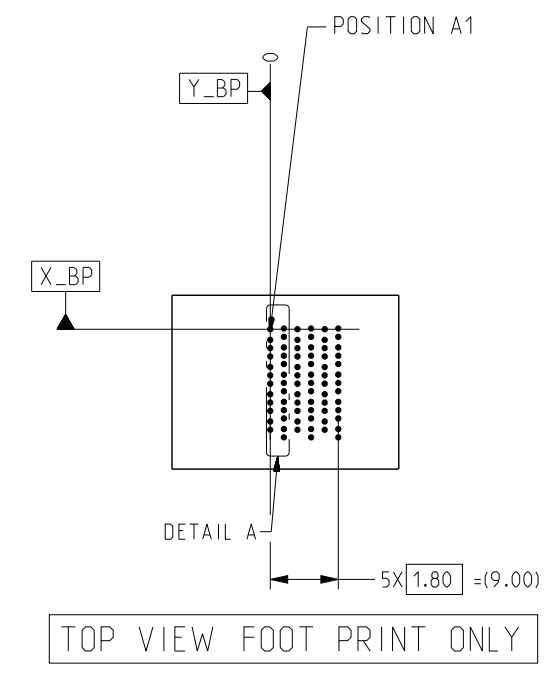

TOP VIEW

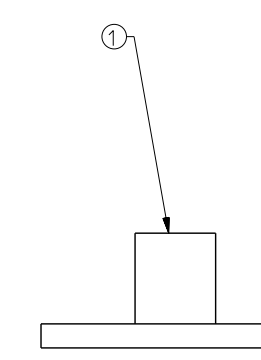

FRONT VIEW

ITEM	PART NUMBER	DESCRIPTION	QTY
1	923-400C-40H	XCede HD 4PAIR 6POS. OPEN, 3MM W IPE, .0177" DRILL, NANO NI, STD GOLD	1

CUSTOMER: DISTRIBUTOR / XHD 4PAIR X 6, HSD 850HMS

TOLERANCES	DESIGN 10/12/2022 J.LIU	Amphenol TCS A Division of Amphenol Corporation 200 Innovative Way, Nashua, NH 03062 803.879.3000 TITLE XCede HD BACKPLANE ASSEMBLY 4 PAIR CONNECTOR, LEADFREE PART NO. JX410-51602 DRAWING NO. C-JX410-51602 CRED FILES JX410-51602_BP_ASM JX410-51602_BP.DRW	REV A	
0.0 ±0.25	DRAWN 10/12/2022 AUTO GENERATED			
0.00 ±0.13	CHK 10/12/2022 J.LIU			
0.000 ± -	APVD 11/15/2022 J.LIU			
ANGLES ± 3°				
UNLESS OTHERWISE SPECIFIED DIMENSIONS ARE IN MM AND DECIMAL MARKER IS A PERIOD.		SIZE D	SCALE 1/1	SHEET 2 OF 2

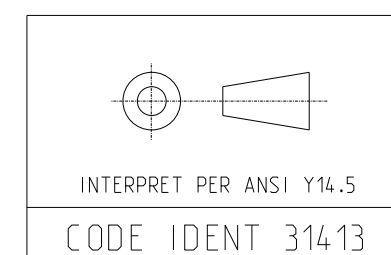

CUSTOMER USE
 DRAWING