

4
DRAWING MADE IN THIRD ANGLE PROJECTION
THIS DRAWING IS UNPUBLISHED. RELEASED FOR PUBLICATION
© COPYRIGHT 19 BY AMP INCORPORATED. ALL INTERNATIONAL RIGHTS RESERVED.

LOC	DIST	P	F	ZONE	LTR	DESCRIPTION	DATE	APPD
CE	16				0	REL PER NPR 87-195	1/16/88	Dr. Thompson

1. DIMENSIONS IN [] ARE IN INCHES

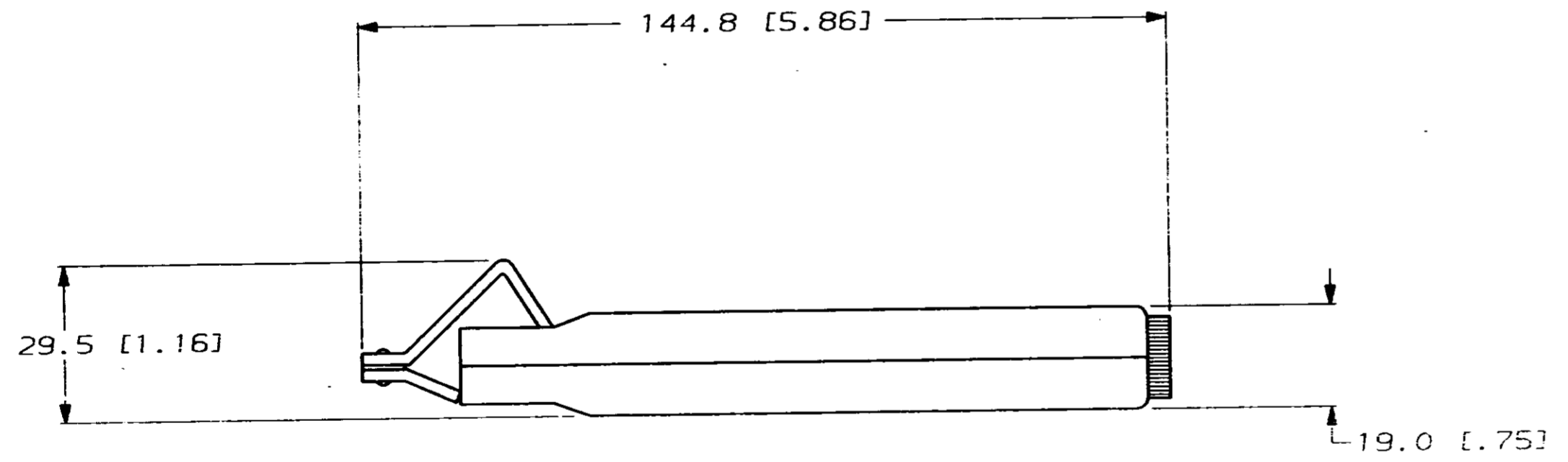
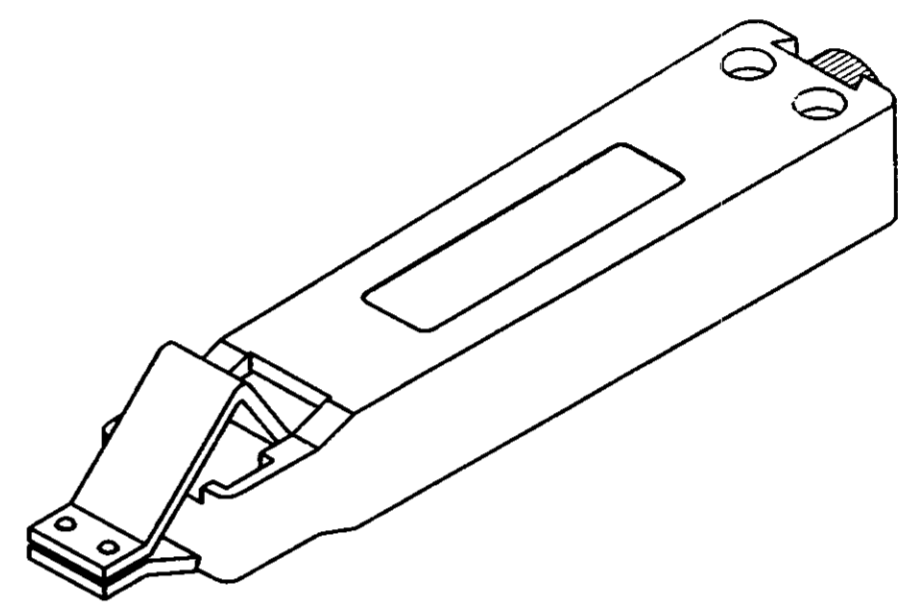
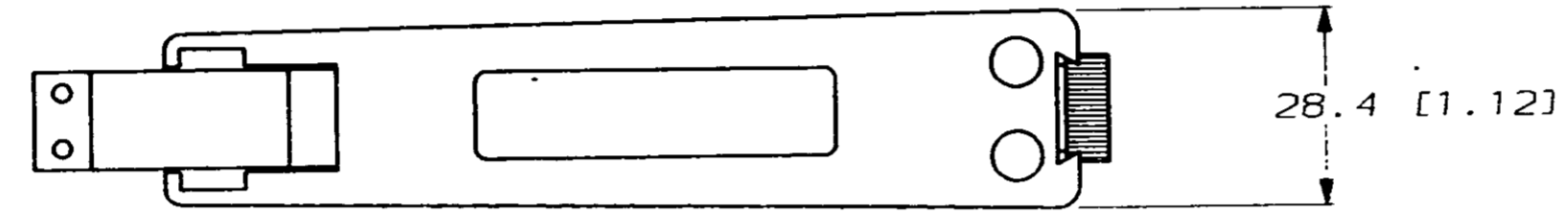

501715-1
PART NO

DO NOT SCALE PRINT. UNLESS SPECIFIED DIMENSIONS IN mm TOLERANCES ON: 2 PLC DEC ± 0.8 [0.03] 3 PLC DEC ± - ANGLES ± -	DR <i>S. Knudsen</i> 1/19/88
	CHK <i>[Signature]</i> 1-18-88
MATERIAL	APPD <i>Dr. Thompson</i> 1-19-88
FINISH	PRODUCT SPEC
WEIGHT	APPLICATION SPEC

AMP AMP INCORPORATED Harrisburg, Pa. 17105		
NAME CABLE STRIPPER, OPTIMATE		
SIZE C	FSCM NO 00779	DRAWING NO 501715
SCALE NTS	SHEET 1 OF 1	

METRIC

CUSTOMER DRAWING