

FACE VIEW-MALE INSERT

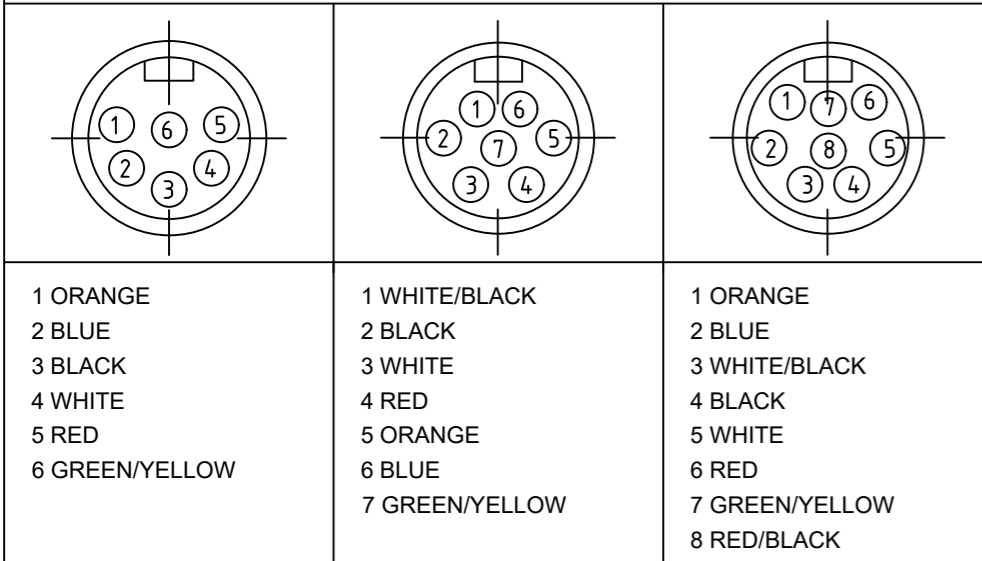

1 ORANGE 2 BLUE 3 BLACK 4 WHITE 5 RED 6 GREEN/YELLOW	1 WHITE/BLACK 2 BLACK 3 WHITE 4 RED 5 ORANGE 6 BLUE 7 GREEN/YELLOW	1 ORANGE 2 BLUE 3 WHITE/BLACK 4 BLACK 5 WHITE 6 RED 7 GREEN/YELLOW 8 RED/BLACK
---	--	---

PART NO. MATRIX

2R7006A20M010

POLES  
6-8

FINISHED LENGTH:  
A120= 12 IN.  
F060= 6 FEET  
F120= 12 FEET

M005= 0.5 METER  
M010= 1 METER  
M100= 10 METER

CABLE LENGTH TOLERANCES

<.3M [1FT]:	+19mm-0 [+ .75in-0]
.3 - .9M [1 - 3FT]:	+44.5mm-0 [+1.75in-0]
.9 - 1.8M [3 - 6FT]:	+55.6mm-0 [+2.19in-0]
1.8 - 3.7M [6 - 12FT]:	+88.9mm-0 [+3.50in-0]
3.7 - 7.3M [12 - 24FT]:	+165.1mm-0 [+6.50in-0]
7.3-14.6M [24 - 48FT]:	+317.5mm-0 [+12.50in-0]
14.6 - 30.5M [48-100FT]:	+622.3mm-0 [+24.50in-0]
OVER 30M [100FT]	+2% OF FINISHED LENGTH

NOTES:

- MATERIAL: AS NOTED
- FINISH: AS NOTED
- ELECTRICAL:  
VOLTAGE: 6 THRU 8P 600V PER UL 2238  
6P 400V PER IEC 60664  
7 & 8P 320V PER IEC 60664  
CURRENT: 6 & 7 POLE: 8A  
8 POLE: 7A
- TEMP RATING: -20°TO +105°C
- PROTECTION: IP67 (WHEN MATED)
- UL LISTED, FILE: E152210  
CSA CERTIFIED, FILE: LR6837
- ALL DIMENSIONS ARE FOR REFERENCE UNLESS TOLERANCED OR NOTED OTHERWISE

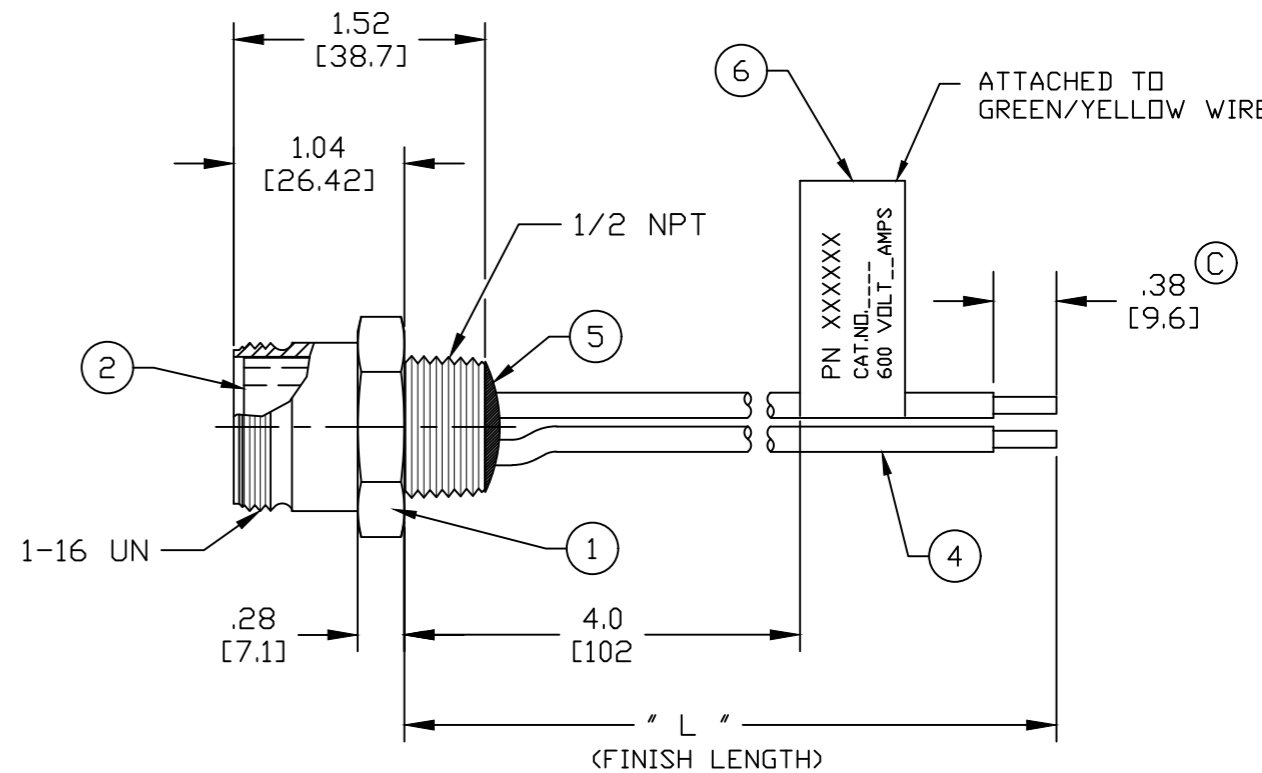
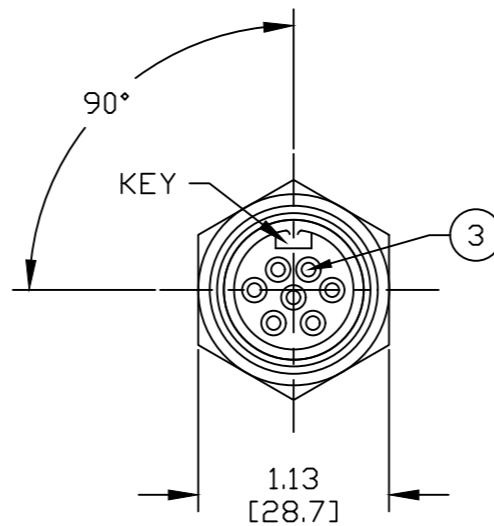
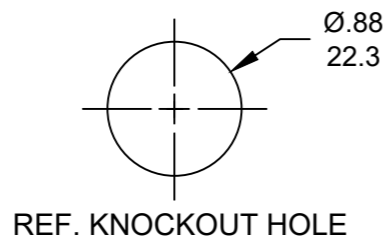

6	LABEL	VINYL	BLACK/YELLOW
5	POTTING MATERIAL	EPOXY	
4	WIRE, 16 AWG UL (1015)	PVC INSULATION	SEE FACE VIEW
3	CONTACT PIN	COPPER ALLOY	GOLD PLATED
2	INSERT	TPE	YELLOW
1	RECEPTACLE SHELL	ZINC DIE-CAST	BLACK
ITEM	DESCRIPTION	MATERIAL	FINISH

PART NO	ENGINEERING NO.	FINISHED LENGTH
1300140025	2R6006A20A120	12 IN [0.3M]
1300140149	2R7006A20F300	30 FT [9.1M]
1300140058	2R7006A20M005	0.5M [1.6 FT]

THIS DRAWING CONTAINS INFORMATION THAT IS PROPRIETARY TO MOLEX ELECTRONIC TECHNOLOGIES, LLC AND SHOULD NOT BE USED WITHOUT WRITTEN PERMISSION

FUNCTIONAL SYMBOLS:  $F_A=0$ ,  $F_C=0$ ,  $F_P=0$

DIMENSION UNITS: INCH/MM, SCALE: 1:1

GENERAL TOLERANCES (UNLESS SPECIFIED):  
4 PLACES ±--- ±---  
3 PLACES ±--- ±---  
2 PLACES ±--- ±---  
1 PLACE ±--- ±---  
0 PLACES ±--- ±---

ANGULAR TOL ± --- °

DRAFT WHERE APPLICABLE MUST REMAIN WITHIN DIMENSIONS

THIRD ANGLE PROJECTION

DRAWING: B-SIZE, SERIES: 130014

CURRENT REV DESC: ADDED .38 WIRE STRIP, CORRECT CABLE LENGTH TOL. BLOCK, UPDATE BORDER

EC NO: 721990  
DRWN: RSTONE 2022/09/19  
CHK'D: ALEON01 2022/09/23  
APPR: BWOODMAN 2022/09/23

INITIAL REVISION:  
DRWN: RSTONE 2016/12/07  
APPR: BWOODMAN 2017/01/16

DOCUMENT NUMBER: SD-130014-010, DOC TYPE: PSD, DOC PART: 001, REVISION: C

MATERIAL NUMBER: GENERAL MARKET, CUSTOMER: GENERAL MARKET, SHEET NUMBER: 1 OF 1

**molex**

MINI-CHANGE RECEPTACLE, B-SIZE, 6 TO 8 POLE, MALE, STRAIGHT, SINGLE KEY, 16 AWG

PRODUCT CUSTOMER DRAWING