

THIS DRAWING IS UNPUBLISHED. RELEASED FOR PUBLICATION  
 © COPYRIGHT - By - ALL RIGHTS RESERVED.

LOC	DIST	REVISIONS			
P	LTR	DESCRIPTION	DATE	DWN	APVD
GP	00				
G		REVISED PER ECO-12-009966	22JUN2012	CJV	SLB

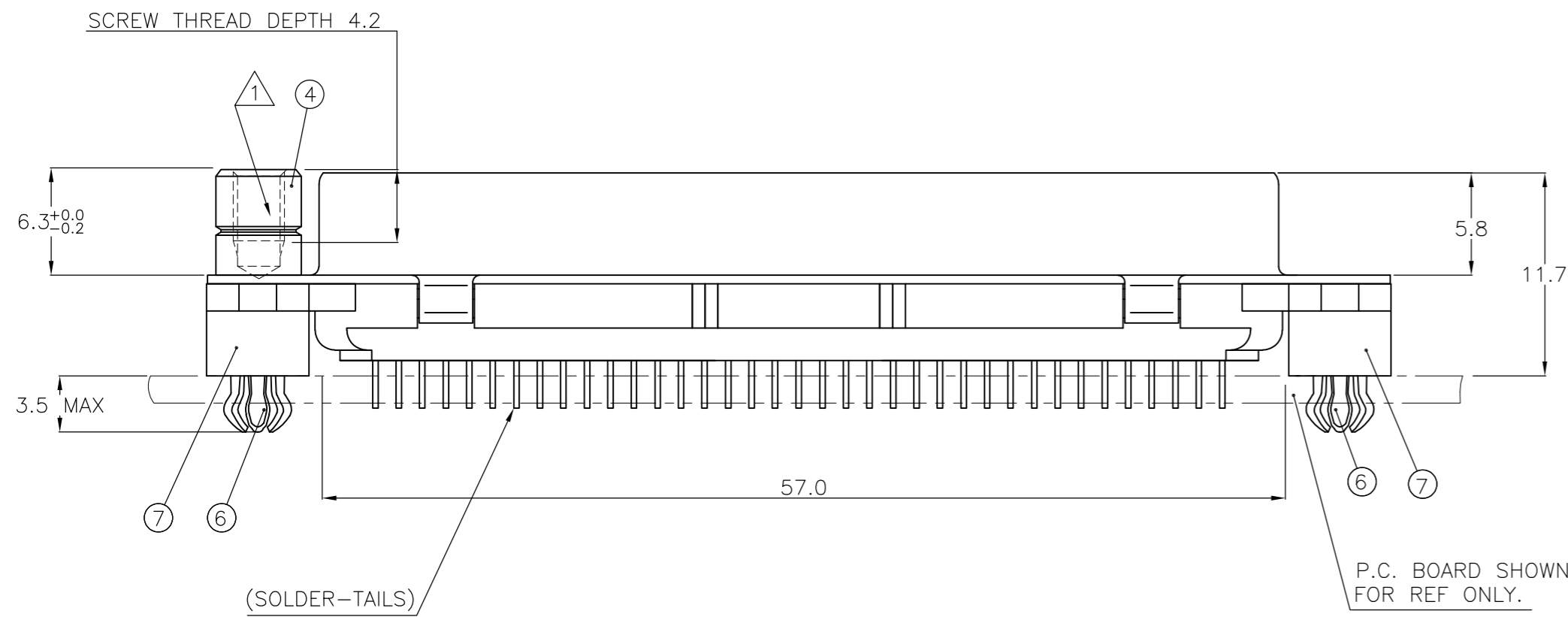
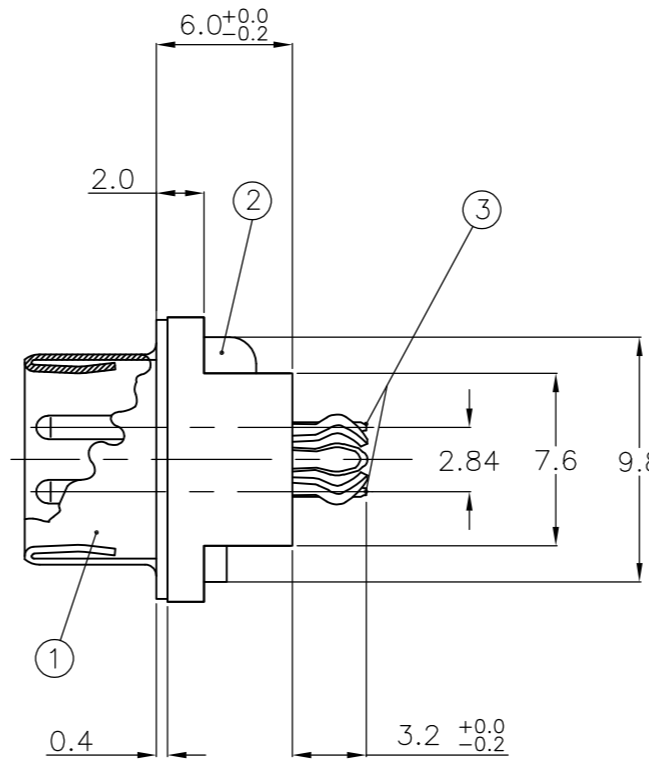
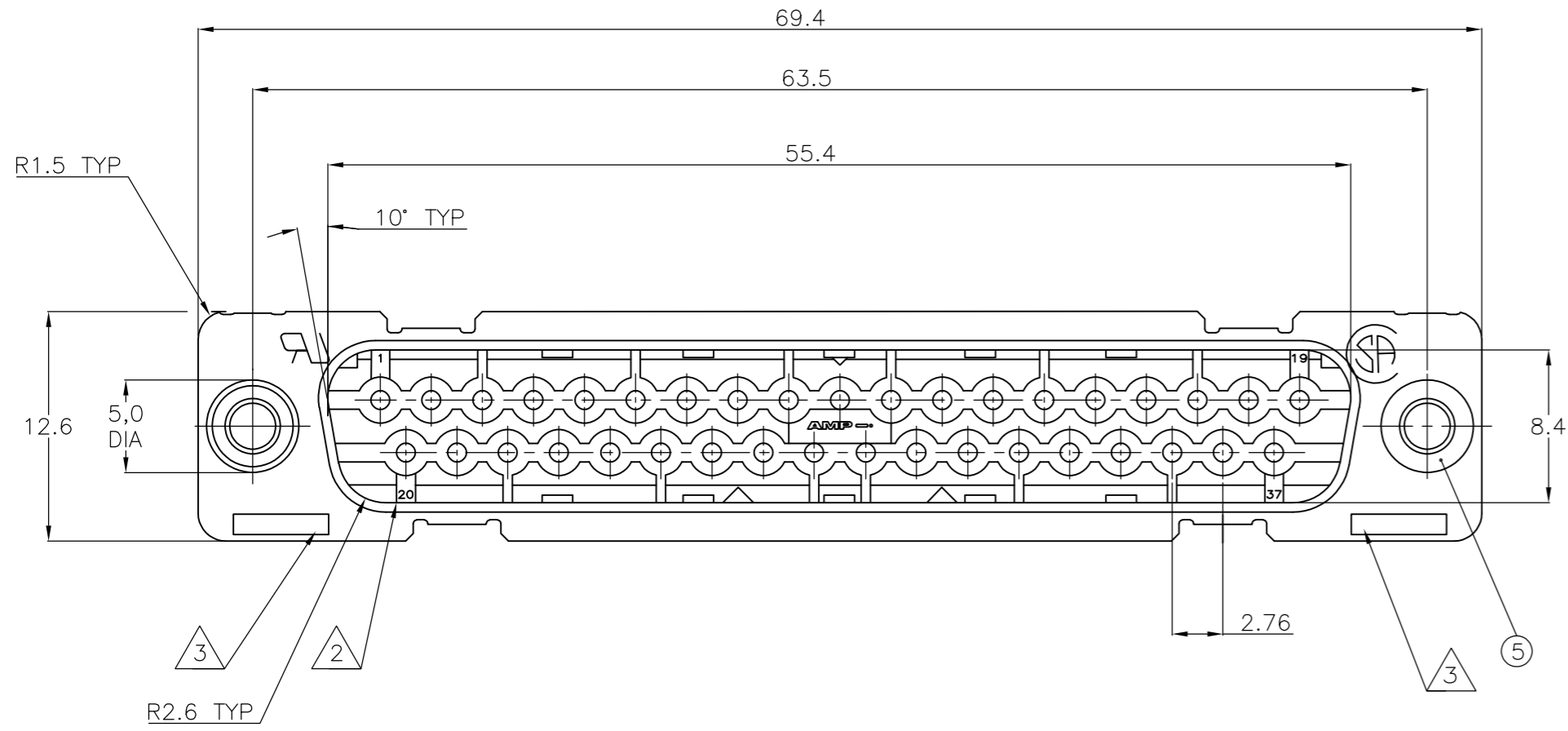

ITEM NO	DESCRIPTION OF ACCESSORY	1	2	3	4	5	6	7	8	9
5	BUSHING WITH THROUGH HOLE $\phi$ 3.1.									
5	BUSHING WITH THREAD 4-40 UNC		2						2	
5	BUSHING WITH THREAD M3			2						2
4	FEMALE SCREWLOCK WITH THREAD 4-40 UNC				2					2
4	FEMALE SCREWLOCK WITH THREAD M3					2				2
6	BOARDLOCK		2	2	2	2				

1-338312-2										
2-338312-2										
3-338312-2										
4-338312-2										
5-338312-2										
6-338312-2										
7-338312-2										
8-338312-2										OBSOLETE
9-338312-2										OBSOLETE

- ① GROOVE INDICATES VERSION WITH 4-40 UNC INNER THREAD; WITHOUT GROOVE INDICATES VERSION WITH M3 INNER THREAD.
- ② CAVITY IDENTIFICATION AT FRONT SIDE ONLY.
- ③ PART NUMBER AND DATE CODE.
- 4 WHEN BOARDLOCKS ARE USED, CONNECTOR CAN BE USED FOR PCB THICKNESS OF 1.6 ONLY.
- 5 SHELL HAS 2x12 GROUNDING SPRINGS; PITCH IS 3.6.
- 6 AIR AND CREEPAGE DISTANCES ACCORDING TO DIN 41652.
- 7 CONTACT FINISH: GOLD FLASH OVER PALLADIUM-NICKEL PLATE OR GOLD PLATE ON THE MATING SURFACES, TIN PLATE ON THE SOLDER-TAILS, NICKEL UNDERPLATE ON THE ENTIRE CONTACT. MATING SURFACE FINISH MEETS LEVEL 2 PER DIN 41652.

- ITEM NO/MATERIAL :
- ① SHELL : BRIGHT TIN PLATED STEEL
  - ② HOUSING : GLASS FILLED POLYESTER, COLOR : BLACK
  - ③ CONTACTS : PHOSPHOR BRONZE (PLATING : SEE NOTES)
  - ④ FEMALE SCREWLOCK : TIN PLATED STEEL (INNER THREAD 4-40 UNC OR M3)
  - ⑤ BUSHING : TIN PLATED STEEL (INNER THREAD 4-40 UNC OR M3 OR  $\phi$ 3.1 THROUGH HOLE)
  - ⑥ BOARDLOCK : TIN PLATED PHOSPHOR BRONZE
  - ⑦ STAND-OFF : GLASS FILLED NYLON COLOR : BLACK

RECOMMENDED P.C. BOARD HOLE-LAYOUT

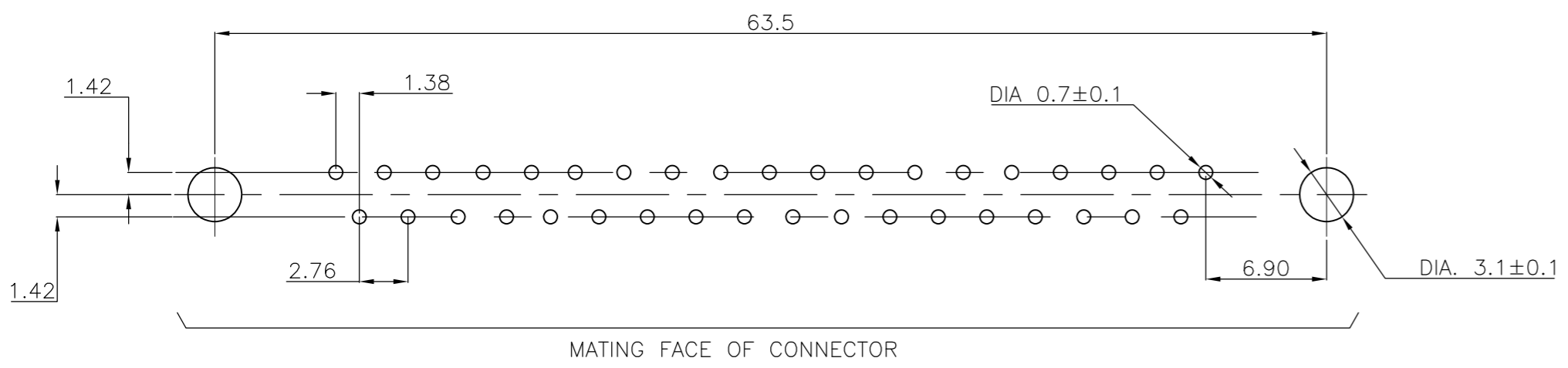

THIS DRAWING IS A CONTROLLED DOCUMENT. DIMENSIONING AND TOLERANCING PER ASME Y14.5M-2009		DWN J.V.LIEMPT 03JUL97		
		CHK C.SOUISA 09SEP97		
DIMENSIONS: mm		APVD E.LEIJTENS 09SEP97	NAME	
TOLERANCES UNLESS OTHERWISE SPECIFIED:		PRODUCT SPEC		
0 PLC ± -		APPLICATION SPEC		
1 PLC ± 0.3		WEIGHT		
2 PLC ± 0.15		SCALE		
3 PLC ± -		SHEET		
4 PLC ± -		REV		
ANGLES ± -		CUSTOMER DRAWING		
FINISH		RESTRICTED TO		

MATERIAL: - FINISH: - WEIGHT: - SCALE: NTS SHEET: 1 of 1 REV: G

SIZE: A2 CAGE CODE: 00779 DRAWING NO: C=338312