

DO NOT SCALE

DIMENSIONS IN MM.

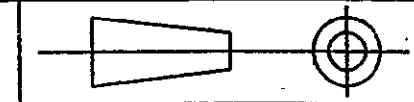

ACTUAL SIZE

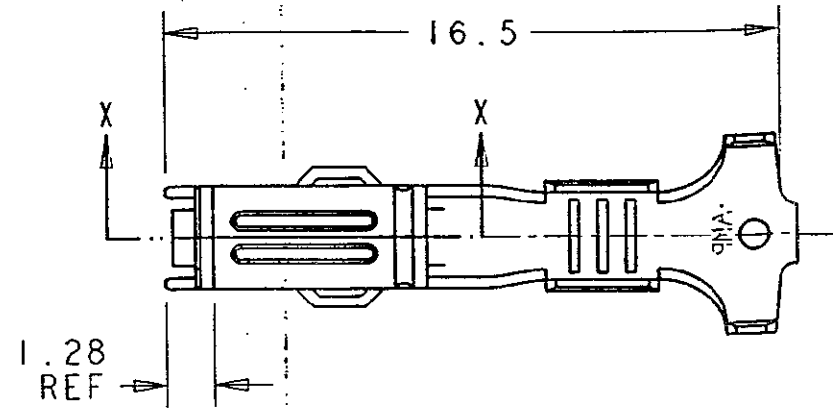

AREA "C", OVER LENGTH OF RIBS.

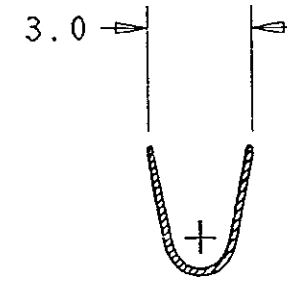
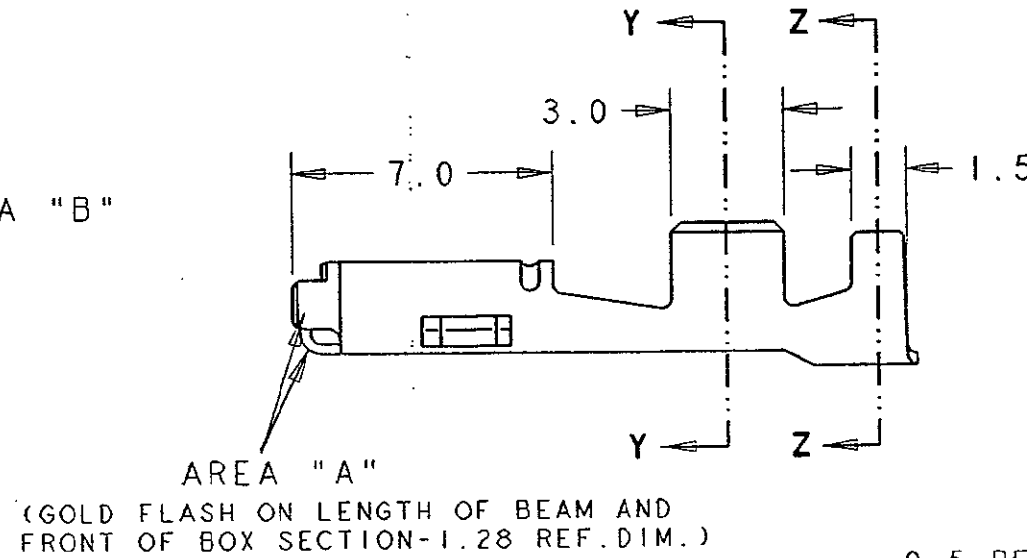
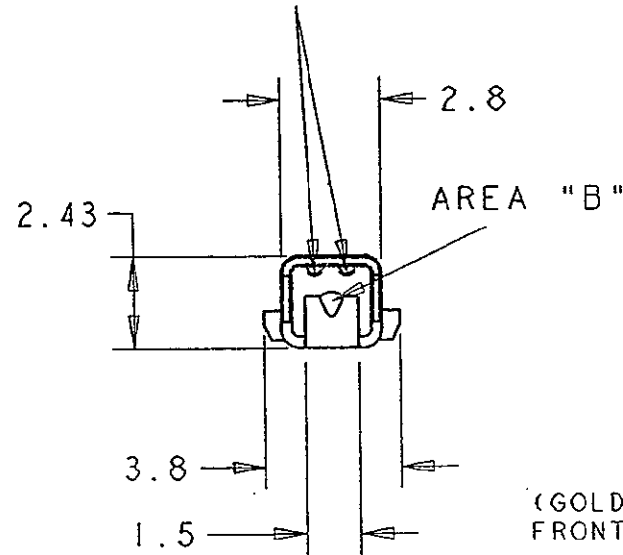

SECTION Y-Y

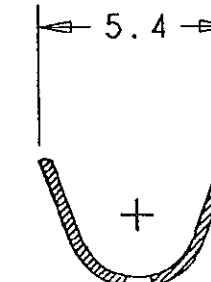

SECTION Z-Z

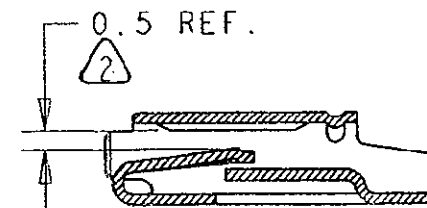

SECTION X-X

NOTES:

1. WIRE RANGE: 0.75 TO 2.0 mm<sup>2</sup>

RECOMMENDED COMBINATIONS FOR SEALED APPLICATIONS		
WIRE SIZE mm <sup>2</sup>	INSULATION DIA. mm	SEAL PT. NO. (SILICONE)
0.75 TO 1.5	1.85 TO 2.4	347874-1
2.0	>2.4 TO 2.7 MAX.	347875-1
2.0	2.2 TO 2.35	347874-1

RECOMMENDED CRIMPING COMBINATIONS FOR UNSEALED APPLICATIONS		
WIRE SIZE mm <sup>2</sup>	INSULATION DIA. mm	TYPE OF INSULATION CRIMP
0.75 TO 1.5	1.85 TO 2.4	SPECIAL "F"
2.0	>2.4 TO 2.7 MAX.	SPECIAL "F"
2.0	2.2 TO 2.35	SPECIAL "F"

2. CLIP GAP TO SUIT 0.64 mm THICK TAB
3. AREAS INDICATED "A", "B" & "C" ARE SELECTIVELY GOLD PLATED.

PROD. SPEC. 108-3114  
APP. SPEC. 114-3040

FOR SEALED AND UNSEALED APPS.

PRE-NICKEL/SELECTIVE GOLD		PHOS. BRONZE	344113-1
FINISH		MATERIAL	PART NUMBER
CUSTOMER DWG FOR REFERENCE ONLY		©COPYRIGHT 1986 BY AMP OF GREAT BRITAIN LTD. ALL INTERNATIONAL RIGHTS RESERVED. ALL PRODUCTS MAY BE COVERED BY BRITISH AND FOREIGN PATENTS AND/OR PATENTS PENDING.	
TOLERANCES UNLESS OTHERWISE STATED:		DR. M.W. 20.11.86 CH. R. RUNAGALL APP. B. J.	
DEC ± 0.5		 TERMINAL HOUSE STANMORE MIDD.	
ANGLES ± 1°		NAME ECONOSEAL 3 - WIRE TO BOARD 0.070 RECEPTACLE CONTACT	
REV	MODIFICATION	ECN	DATE
B	GOLD FLASH NOTE ADDED WIRE NOW 0.75 - 2.0 BOX HT. TOL. ALTERED	EB00-0344-95	10.10.95
A	WIRE SIZE WAS 0.5 - 1.5mm <sup>2</sup>	C6087	20.02.92
0	RELEASE TO PRODUCTION	C5373	28.09.89
5/1	E	A3	C344113
SCALE	LOC	SIZE	DWG. No.
REV	SHEET	B	1/1