

STRAIGHT PLUG SOLDER TYPE

R223.062.000

CABLE .085

Series : MMBX

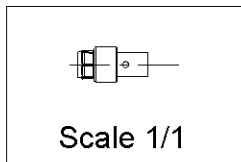
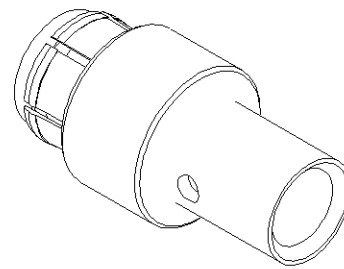
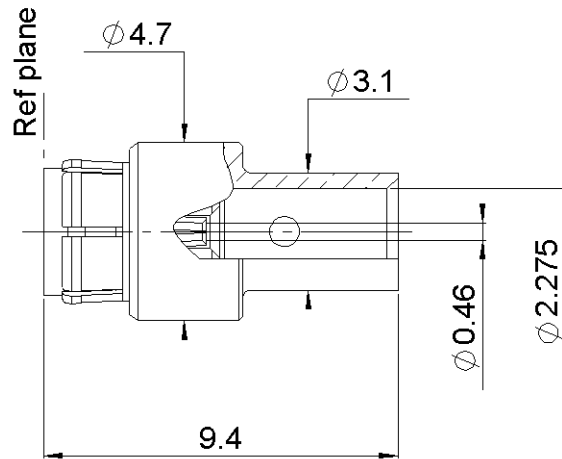

All dimensions are in mm.

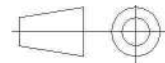

COMPONENTS	MATERIALS	PLATING (μm)
BODY	BRASS	NPGR
CENTER CONTACT	BERYLLIUM COPPER	NPGR
OUTER CONTACT	BERYLLIUM COPPER	NPGR
INSULATOR	PTFE	
GASKET		
OTHERS PARTS		
-	-	-
-	-	-

Issue : 0736 B

In the effort to improve our products, we reserve the right to make changes judged to be necessary.



STRAIGHT PLUG SOLDER TYPE

R223.062.000

CABLE .085

Series : **MMBX**

PACKAGING

Standard	Unit	Other
100	'W' option	Contact us

SPECIFICATION

ELECTRICAL CHARACTERISTICS

Impedance		50 Ω
Frequency		0-12.4 GHz
VSWR	1.22 +	0,0000 x F(GHz) Maxi
Insertion loss		0.12 √F(GHz) dB Maxi
RF leakage	- (100 - F(GHz)) dB Maxi
Voltage rating		250 Veff Maxi
Dielectric withstanding voltage		750 Veff mini
Insulation resistance		1000 MΩ mini

CABLE ASSEMBLY

Stripping	a	b	c	d	e	f
mm	1,50	0,00	0,00	0,00	0,00	0,00

Assembly instruction :

Recommended cable(s)
RG 405

-
Characteristics indicated on this data sheet are those that can be achieved with the highest performance cable. Intrinsic limitations of the cable may diminish the performance of the assembly

Cable retention

- pull off **136** N mini
- torque **NA** N.cm

MECHANICAL CHARACTERISTICS

Center contact retention		
Axial force – Mating end	10	N mini
Axial force – Opposite end	10	N mini
Torque	NA	N.cm mini

TOOLING

Part Number	Description	Hexagon
.	.	.
R282.051.000	STRIPPING TOOL	
R282.062.000	POINTER GAUGE	
R282.740.000	SOLDERING MOUNTING	

Recommended torque		
Mating	NA	N.cm
Panel nut	NA	N.cm
Clamp nut	NA	N.cm
A/F clamp nut	0,0000	mm

Mating life	100	Cycles mini
Weight	0,4930	g

OTHER CHARACTERISTICS

Interface MMBX only up to 2.5 GHz
VSWR 1.04+0.01xF(GHz) : 0 at 6GHz
VSWR 1.10+0.01xF(GHz) : 6 at 12.4GHz

ENVIRONMENTAL

Operating temperature	-55/+155	°C
Hermetic seal	NA	Atm.cm3/s
Panel leakage	NA	

Issue : **0736 B**

In the effort to improve our products, we reserve the right to make changes judged to be necessary.



STRAIGHT PLUG SOLDER TYPE

R223.062.000

CABLE .085

Series : MMBX

COMPONENT

STRIPPING DIMENSION

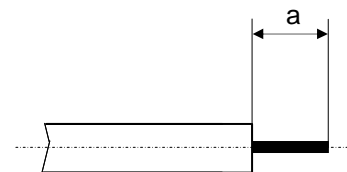
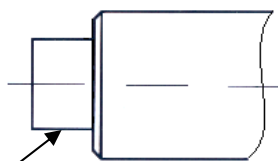

CONNECTOR BODY

We recommend a thermal preconditioning cable.

1

Strip the cable.
 Stripping tool : R282.051.000 .
 Positioner : R282.062.000 .

Trim cable center conductor.
 Trimmer : R282.062.000 .

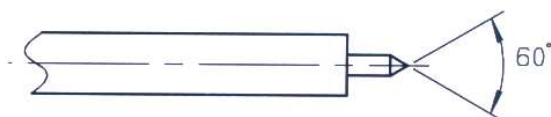

2

Slide cable into connector body until it contacts the body shoulder.
 Place sub assembly into the assembly jig : R282.740.000
 Insulator bottoms against the assembly jig .
 Solder body onto cable.
 Let the assembly cool down before removing it from the jig.
 Clean the solder area.

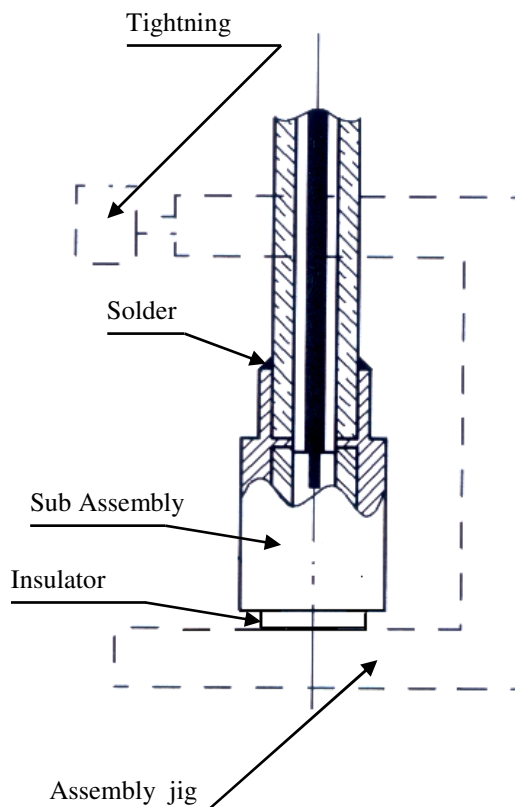

Issue : 0736 B

In the effort to improve our products, we reserve the right to make changes judged to be necessary.

