



# *SpeedPLUS™* 8-Bit, 30MHz Sampling ANALOG-TO-DIGITAL CONVERTER

## FEATURES

- +3V TO +5V SUPPLY OPERATION
- INTERNAL REFERENCE
- SINGLE-ENDED INPUT RANGE: 1V to 2V
- LOW POWER: 66mW at +3V
- HIGH SNR: 46dB
- LOW DNL: 0.4LSB
- SSOP-28 PACKAGE

## APPLICATIONS

- BATTERY POWERED EQUIPMENT
- CAMCORDERS
- PORTABLE TEST EQUIPMENT
- COMPUTER SCANNERS
- COMMUNICATIONS

## DESCRIPTION

The ADS930 is a high speed pipelined Analog-to-Digital Converter (ADC) specified to operate from nominal +3V or +5V power supplies with tolerances of up to 10%. This complete converter includes a high bandwidth track/hold, a 8-bit quantizer and an internal reference.

The ADS930 employs digital error correction techniques to provide excellent differential linearity for demanding imaging applications. Its low distortion and high SNR give the extra margin needed for telecommunications, video and test instrumentation applications.

This high performance ADC is specified for performance at a 30MHz sampling rate. The ADS930 is available in a SSOP-28 package.

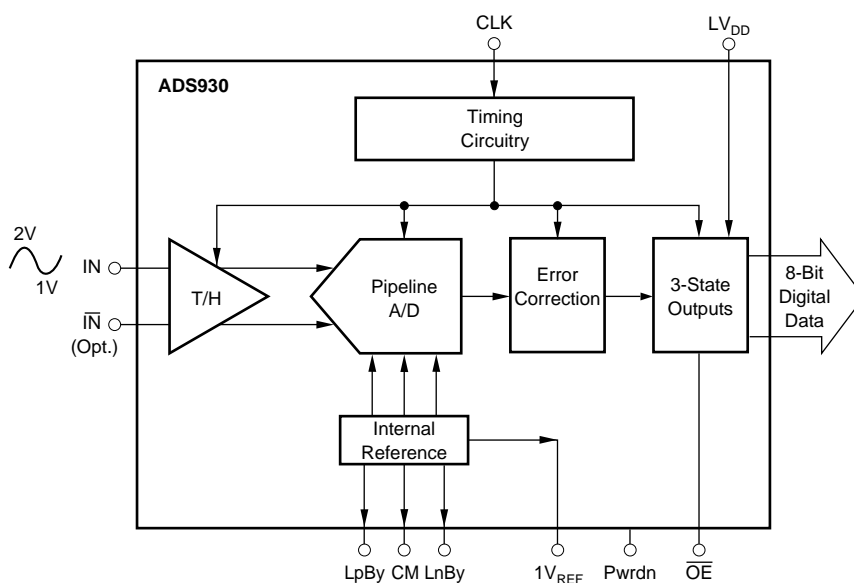

Please be aware that an important notice concerning availability, standard warranty, and use in critical applications of Texas Instruments semiconductor products and disclaimers thereto appears at the end of this data sheet.

## ABSOLUTE MAXIMUM RATINGS

+V <sub>S</sub> .....	+6V
Analog Input .....	+V <sub>S</sub> +0.3V
Logic Input .....	+V <sub>S</sub> +0.3V
Case Temperature .....	+100°C
Junction Temperature .....	+150°C
Storage Temperature .....	+150°C



## ELECTROSTATIC DISCHARGE SENSITIVITY

This integrated circuit can be damaged by ESD. Texas Instruments recommends that all integrated circuits be handled with appropriate precautions. Failure to observe proper handling and installation procedures can cause damage.

ESD damage can range from subtle performance degradation to complete device failure. Precision integrated circuits may be more susceptible to damage because very small parametric changes could cause the device not to meet its published specifications.

## PACKAGE/ORDERING INFORMATION

PRODUCT	PACKAGE	PACKAGE DRAWING NUMBER	SPECIFIED TEMPERATURE RANGE	PACKAGE MARKING	ORDERING NUMBER <sup>(1)</sup>	TRANSPORT MEDIA
ADS930E	SSOP-28	324	-40°C to +85°C	ADS930E	ADS930E	Rails
"	"	"	"	ADS930E	ADS930E/1K	Tape and Reel

NOTE: (1) Models with a slash (/) are available only in Tape and Reel in the quantities indicated (e.g., /1K indicates 1000 devices per reel). Ordering 1000 pieces of "ADS930E/1K" will get a single 1000-piece Tape and Reel.

## ELECTRICAL CHARACTERISTICS

At T<sub>A</sub> = +25°C, V<sub>S</sub> = +3V, Single-ended Input and Sampling Rate = 30MHz, unless otherwise specified.

PARAMETER	CONDITIONS	TEMP	ADS930E			UNITS
			MIN	TYP	MAX	
<b>RESOLUTION</b> Specified Temperature Range	Ambient Air		-40	8	+85	Bits °C
<b>ANALOG INPUT</b> Differential Full Scale Input Range Single-Ended Full Scale Input Range Common-mode Voltage Analog Input Bias Current Input Impedance	0.5Vp-p 1Vp-p		+1.25 +1.0	1.5 1 1.25    5	+1.75 +2.0	V V V μA MΩ    pF
<b>DIGITAL INPUTS</b> Logic Family High Input Voltage, V <sub>IH</sub> Low Input Voltage, V <sub>IL</sub> High Input Current, I <sub>IH</sub> Low Input Current, I <sub>IL</sub> Input Capacitance		Full	TTL/HCT Compatible CMOS 2.0			V V μA μA pF
<b>CONVERSION CHARACTERISTICS</b> Start Conversion Sample Rate Data Latency		Full	Rising Edge of Convert Clock 10k			Samples/s Clk Cyc
<b>DYNAMIC CHARACTERISTICS</b> Differential Linearity Error f = 500kHz f = 12MHz No Missing Codes Integral Nonlinearity Error, f = 500kHz Spurious Free Dynamic Range <sup>(1)</sup> f = 500kHz (-1dBFS input) f = 12MHz (-1dB input) Two-Tone Intermodulation Distortion <sup>(3)</sup> f = 3.4MHz and 3.5MHz (-7dBFS each tone) Signal-to-Noise Ratio (SNR) f = 500kHz (-1dBFS input) f = 12MHz (-1dBFS input) Signal-to-(Noise + Distortion) (SINAD) f = 500kHz (-1dBFS input) f = 3.58MHz (-1dBFS input) f = 12MHz (-1dBFS input)	Largest Code Error Largest Code Error	Full Full Full Full Full Full Full Full Full Full Full	46	±0.4 ±0.4 Guaranteed 51 50 54 46 46 45 45 45	±1 ±2.5	LSB LSB LSB dBFS <sup>(2)</sup> dBFS dBc dB dB dB dB dB

# ELECTRICAL CHARACTERISTICS (Cont.)

At  $T_A = +25^\circ\text{C}$ ,  $V_S = +3\text{V}$ , Single-ended Input and Sampling Rate = 30MHz, unless otherwise specified.

PARAMETER	CONDITIONS	TEMP	ADS930E			UNITS
			MIN	TYP	MAX	
Differential Gain Error	NTSC, PAL			2.3		%
Differential Phase Error	NTSC, PAL			1		degrees
Output Noise	Input Grounded			0.2		LSBs rms
Aperture Delay Time				2		ns
Aperture Jitter				7		ps rms
Analog Input Bandwidth						
Small Signal	-20dBFS Input			350		MHz
Full Power	0dBFS Input			100		MHz
Overvoltage Recovery Time <sup>(4)</sup>				2		ns
<b>DIGITAL OUTPUTS</b>	$C_L = 15\text{pF}$					
Logic Family			TTL/HCT Compatible CMOS			
Logic Coding			Straight Offset Binary			
High Output Voltage, $V_{OH}$			+2.4		$V_{DD}$	V
Low Output Voltage, $V_{OL}$					0.4	V
3-State Enable Time	$\overline{OE} = L$			20	40	ns
3-State Disable Time	$OE = H$			2	10	ns
Internal Pull-Down				50		k $\Omega$
Power-Down Enable Time	PwrDn = L			133		ns
Power-Down Disable Time	PwrDn = H			18		ns
Internal Pull-Down				50		k $\Omega$
<b>ACCURACY</b>	$f_s = 2.5\text{MHz}$					
Gain Error		Full		5.9	10	%FS
Input Offset	Referred to Ideal Midscale	Full		$\pm 10$	$\pm 60$	mV
Power Supply Rejection (Gain)	$\Delta V_S = +10\%$	Full		56		dB
Power Supply Rejection (Offset)		Full		56		dB
Internal Positive Reference Voltage		Full		+1.75		V
Internal Negative Reference Voltage		Full		+1.25		V
<b>POWER SUPPLY REQUIREMENTS</b>						
Supply Voltage: $+V_S$	Operating	Full	+2.7	+3.0	+5.25	V
Supply Current: $+I_S$	Operating, +3V	Full		22		mA
Power Dissipation	Operating, +3V	Full		66	84	mW
	Operating, +5V	Full		168		mW
Power Dissipation (Power Down)	Operating, +3V	Full		10		mW
	Operating, +5V	Full		15		mW
Thermal Resistance, $\theta_{JA}$						
SSOP-28				89		$^\circ\text{C/W}$

NOTES: (1) Spurious Free Dynamic Range refers to the magnitude of the largest harmonic. (2) dBFS means dB relative to full scale. (3) Two-tone intermodulation distortion is referred to the largest fundamental tone. This number will be 6dB higher if it is referred to the magnitude of the two-tone fundamental envelope. (4) No "Rollover" of bits.

## PIN CONFIGURATION

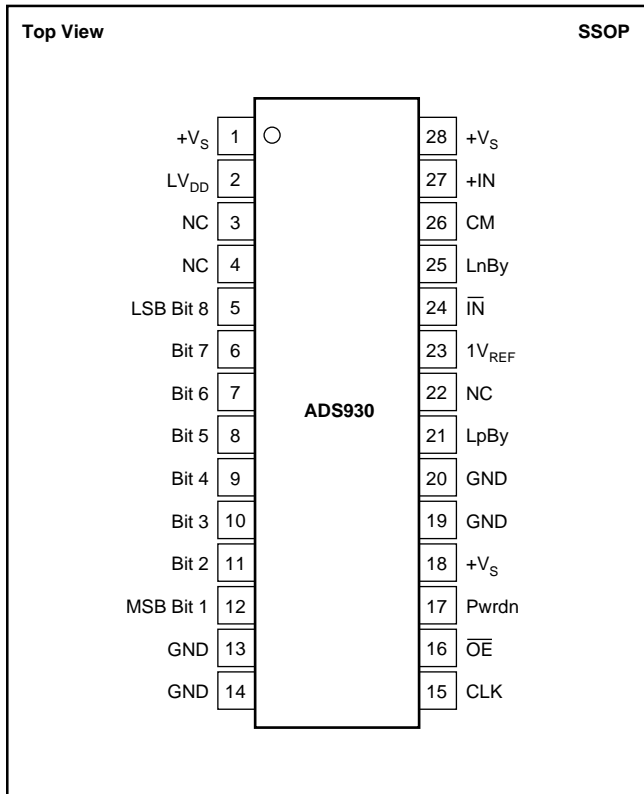

## PIN DESCRIPTIONS

PIN	DESIGNATOR	DESCRIPTION
1	+V <sub>S</sub>	Analog Supply
2	LV <sub>DD</sub>	Output Logic Driver Supply Voltage
3	NC	No Connection
4	NC	No Connection
5	Bit 8 (LSB)	Data Bit 8 (D7)
6	Bit 7	Data Bit 7 (D6)
7	Bit 6	Data Bit 6 (D5)
8	Bit 5	Data Bit 5 (D4)
9	Bit 4	Data Bit 4 (D3)
10	Bit 3	Data Bit 3 (D2)
11	Bit 2	Data Bit 2 (D1)
12	Bit 1(MSB)	Data Bit 1 (D0)
13	GND	Analog Ground
14	GND	Analog Ground
15	CLK	Convert Clock Input
16	$\overline{\text{OE}}$	Output Enable, Active Low
17	PwrDn	Power Down Pin
18	+V <sub>S</sub>	Analog Supply
19	GND	Analog Ground
20	GND	Analog Ground
21	LpBy	Positive Ladder Bypass
22	NC	No Connection
23	1V <sub>REF</sub>	1V Reference Output
24	$\overline{\text{IN}}$	Complementary Input
25	LnBy	Negative Ladder Bypass
26	CM	Common-Mode Voltage Output
27	+IN	Analog Input
28	+V <sub>S</sub>	Analog Supply

## TIMING DIAGRAM

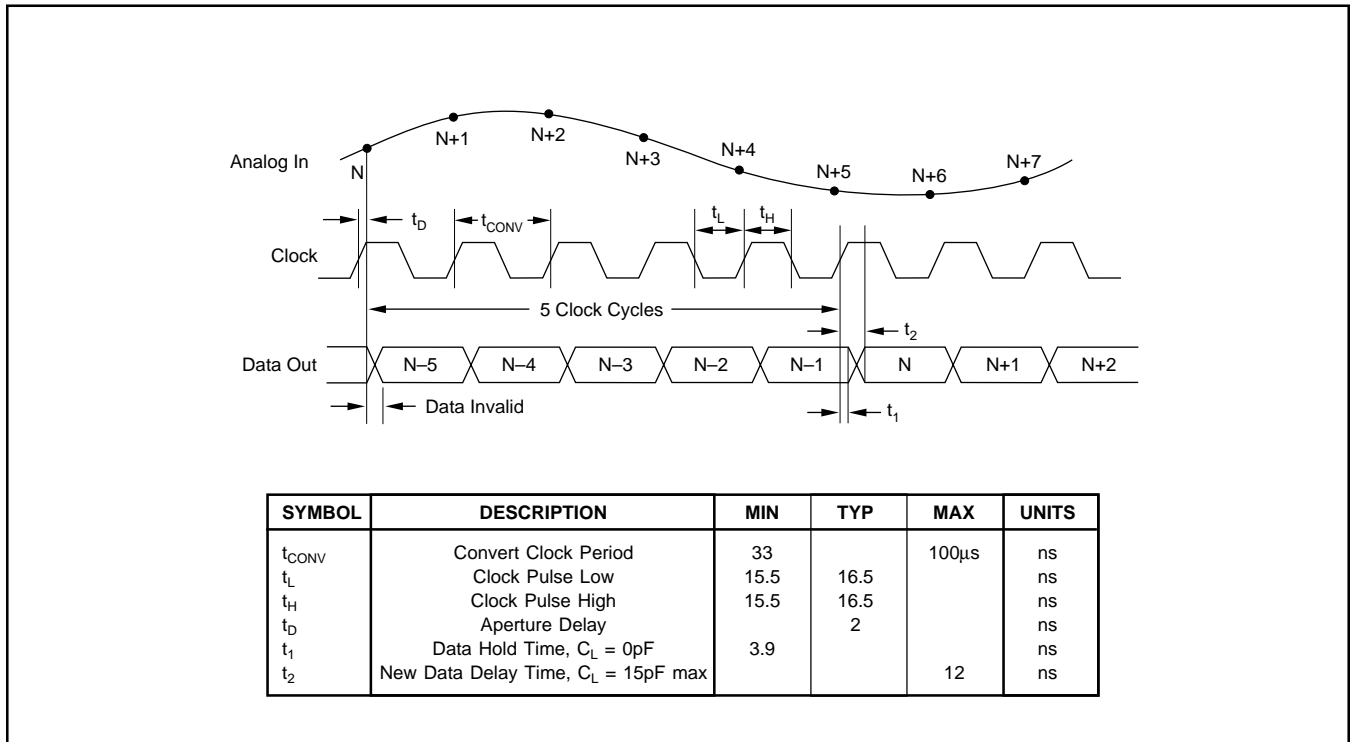

# TYPICAL CHARACTERISTICS

At  $T_A = +25^\circ\text{C}$ ,  $V_S = +3\text{V}$ , Single-ended Input and Sampling Rate = 30MHz, unless otherwise specified.

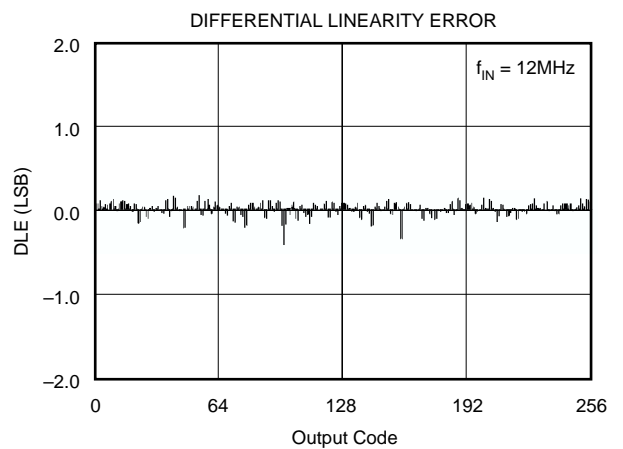
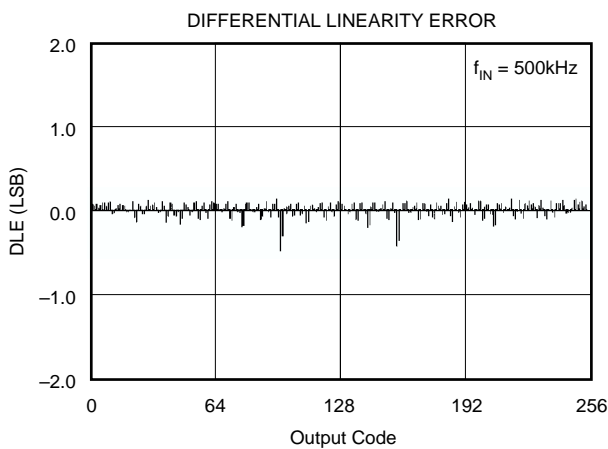
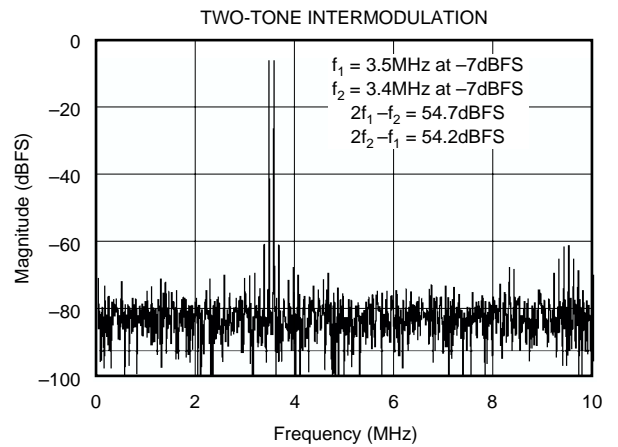
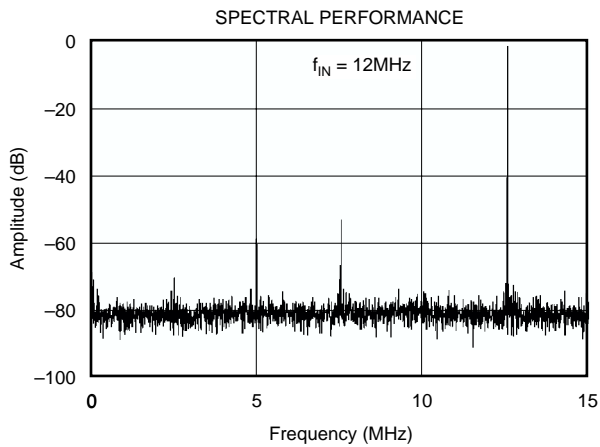
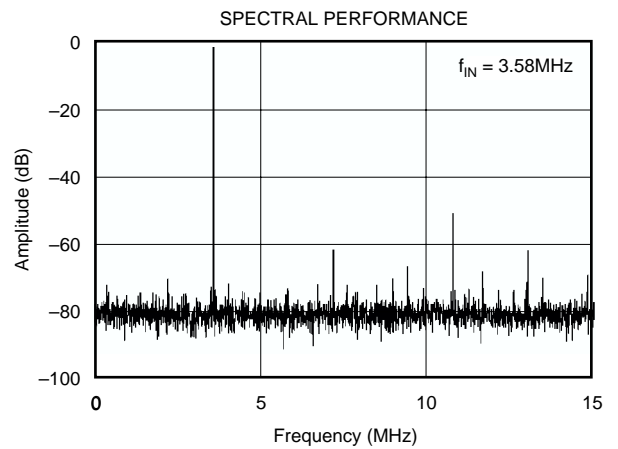
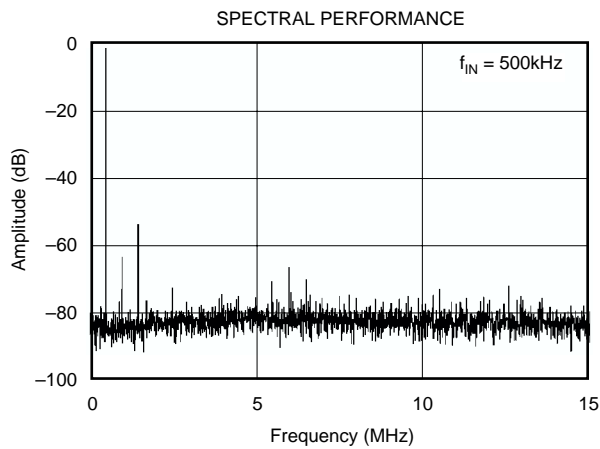

# TYPICAL CHARACTERISTICS (Cont.)

At  $T_A = +25^\circ\text{C}$ ,  $V_S = +3\text{V}$ , Single-ended Input and Sampling Rate = 30MHz, unless otherwise specified.

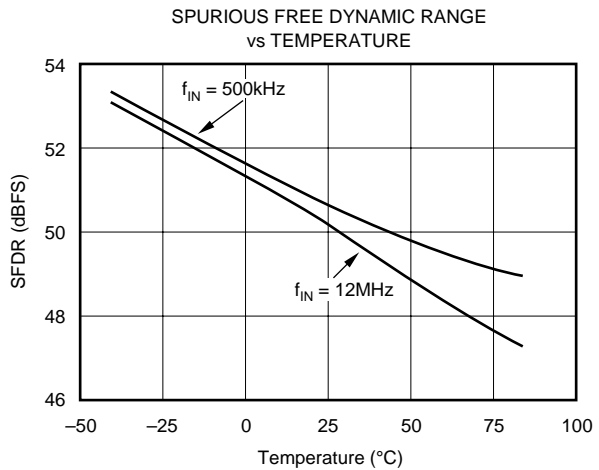
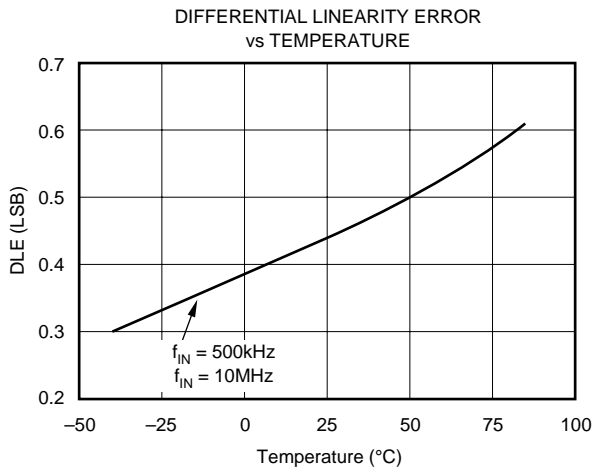
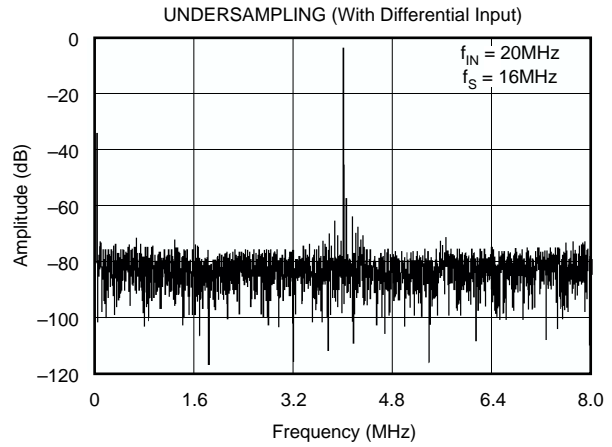
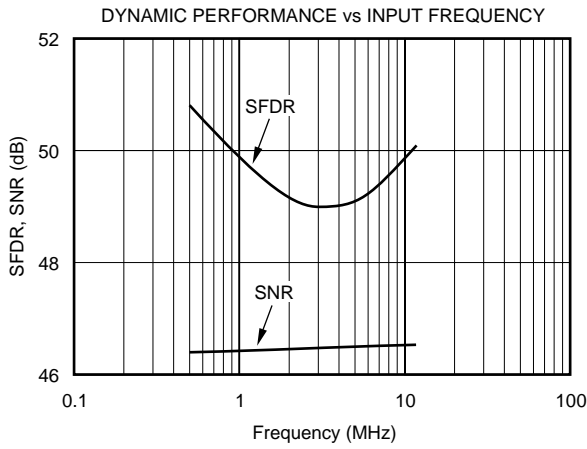
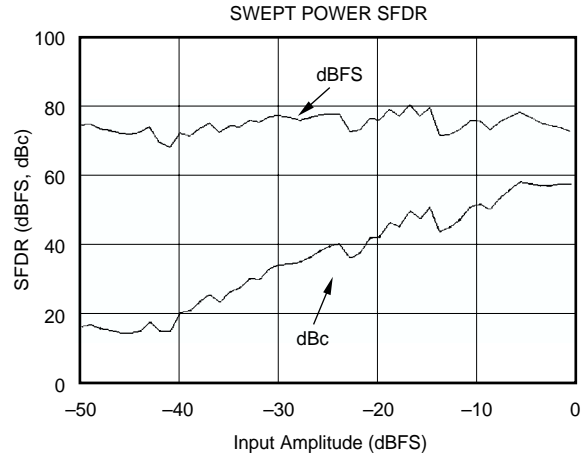
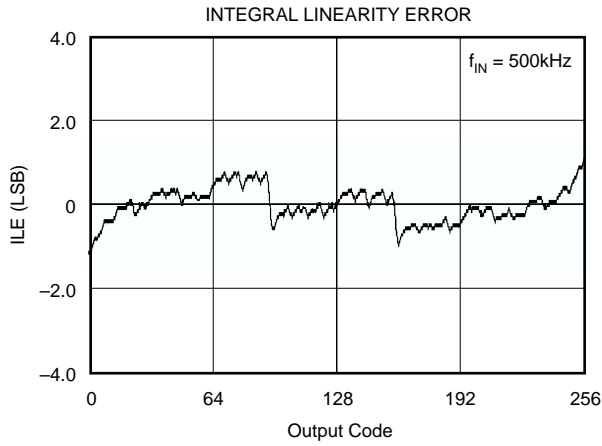

# TYPICAL CHARACTERISTICS (Cont.)

At  $T_A = +25^\circ\text{C}$ ,  $V_S = +3\text{V}$ , Single-ended Input and Sampling Rate = 30MHz, unless otherwise specified.

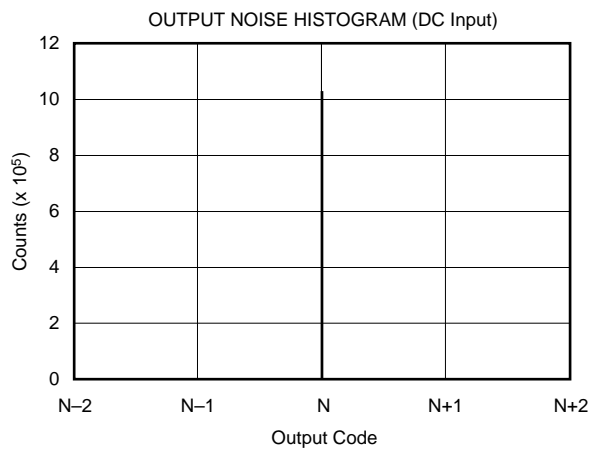
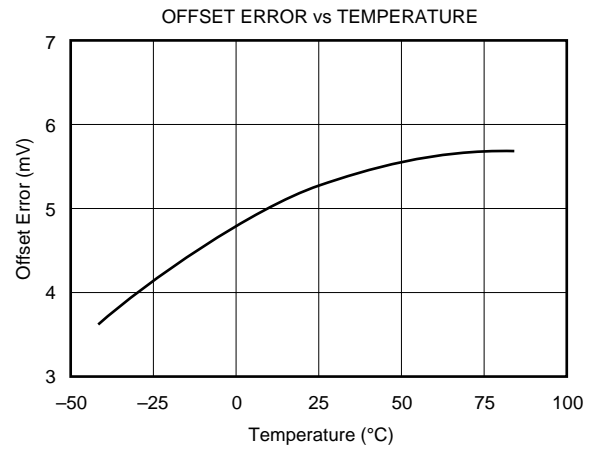
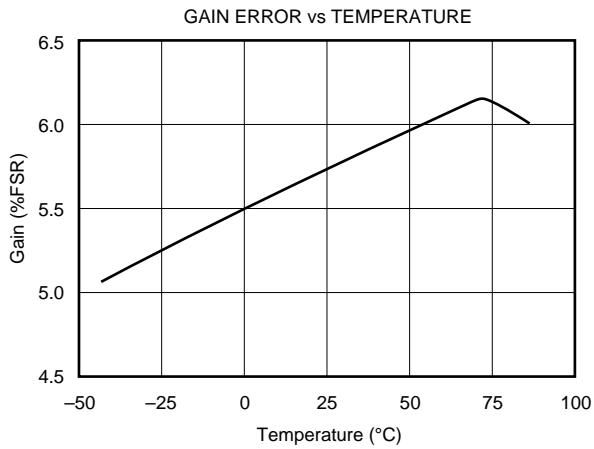
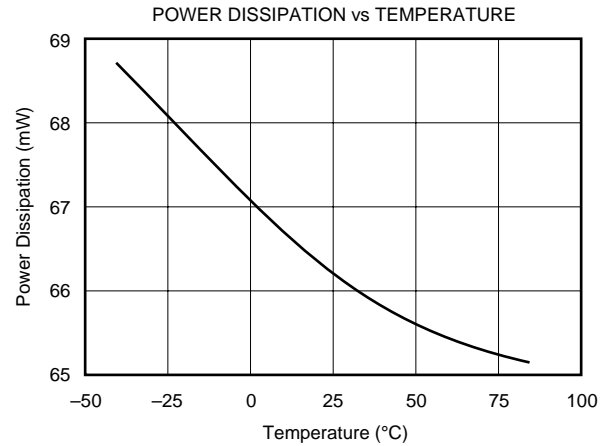
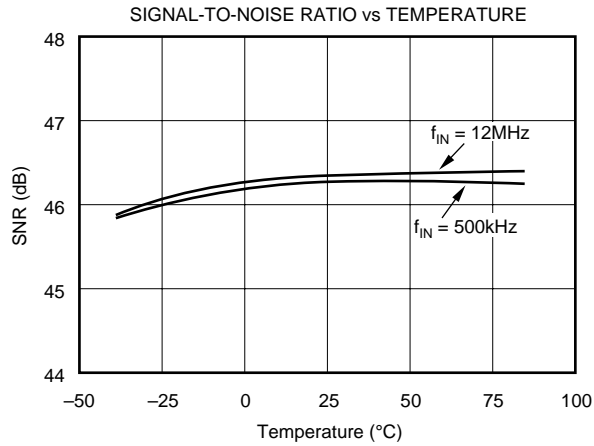

# THEORY OF OPERATION

The ADS930 is a high speed sampling ADC that utilizes a pipeline architecture. The fully differential topology and digital error correction guarantee 8-bit resolution. The track/hold circuit is shown in Figure 1. The switches are controlled by an internal clock which has a non-overlapping two phase signal,  $\phi 1$  and  $\phi 2$ . At the sampling time the input signal is sampled on the bottom plates of the input capacitors. In the next clock phase,  $\phi 2$ , the bottom plates of the input capacitors are connected together and the feedback capacitors are switched to the op amp output. At this time the charge redistributes between  $C_I$  and  $C_H$ , completing one track/hold cycle. The differential output is a held DC representation of the analog input at the sample time. In the normal mode of operation, the complementary input is tied to the common-mode voltage. In this case, the track/hold circuit converts a single-ended input signal into a fully differential signal for the quantizer. Consequently, the input signal gets amplified by a gain or two, which improves the signal-to-noise performance. Other parameters such as small-signal and full-power bandwidth, and wideband noise are also defined in this stage.

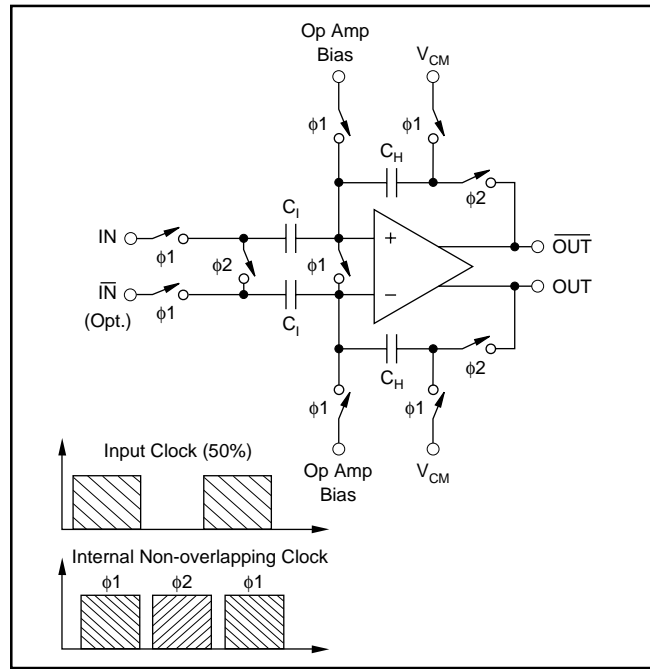

FIGURE 1. Input Track/Hold Configuration with Timing Signals.

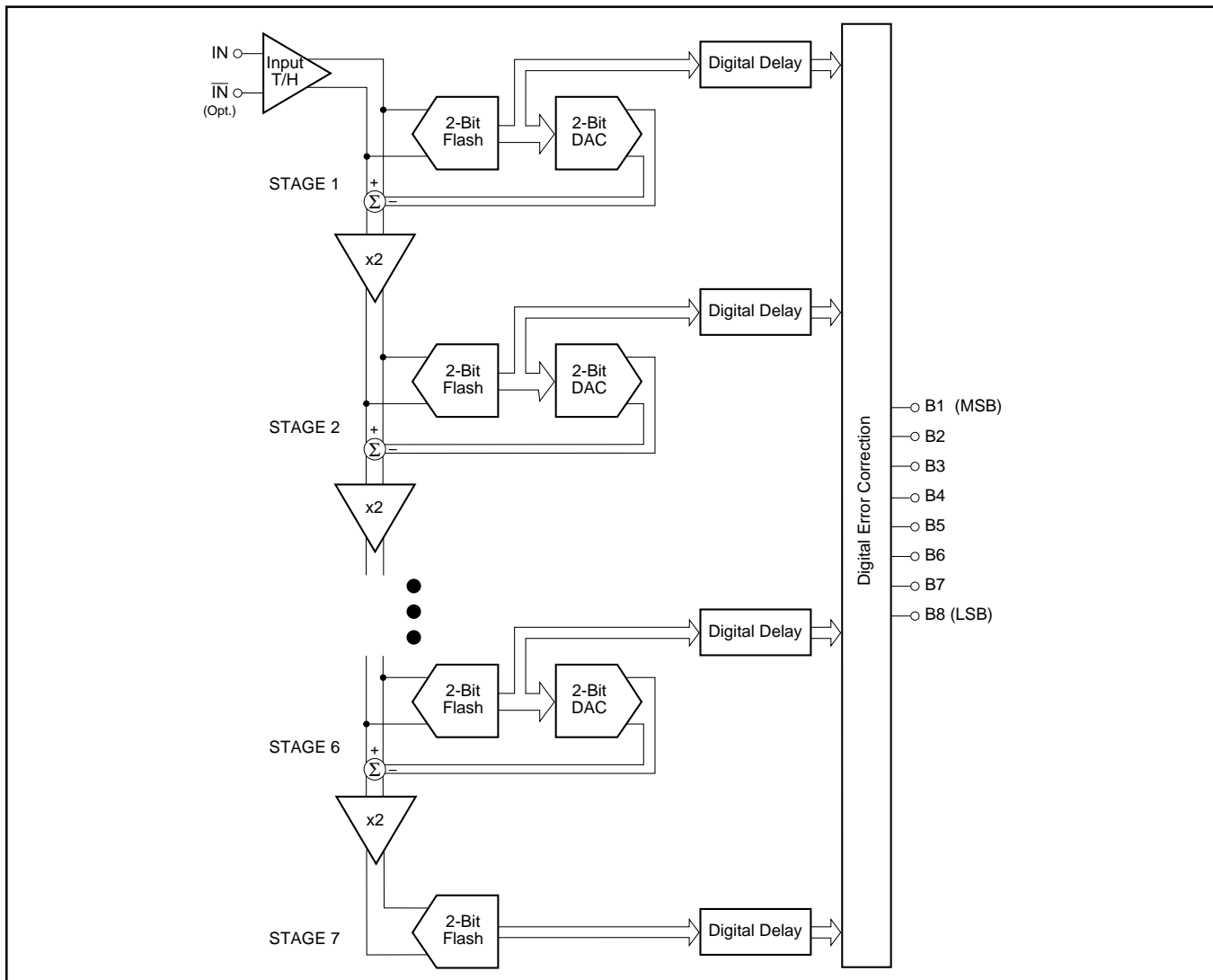

FIGURE 2. Pipeline ADC Architecture.



The pipelined quantizer architecture has 7 stages with each stage containing a two-bit quantizer and a two bit Digital-to-Analog Converter (DAC), as shown in Figure 2. Each two-bit quantizer stage converts on the edge of the sub-clock, which is the same frequency of the externally applied clock. The output of each quantizer is fed into its own delay line to time-align it with the data created from the subsequent quantizer stages. This aligned data is fed into a digital error correction circuit which can adjust the output data based on the information found on the redundant bits. This technique provides the ADS930 with excellent differential linearity and guarantees no missing codes at the 8-bit level.

The ADS930 includes an internal reference circuit that provides the bias voltages for the internal stages (for details see “Internal Reference”). A midpoint voltage is established by the built-in resistor ladder which is made available at pin 26 “CM”. This voltage can be used to bias the inputs up to the recommended common-mode voltage or to level shift the input driving circuitry. The ADS930 can be used in both a single-ended or differential input configuration. When operated in single-ended mode, the reference midpoint (pin 26) should be tied to the inverting input, pin 24.

To accommodate a bipolar signal swing, the ADS930 operates with a common-mode voltage ( $V_{CM}$ ) which is derived from the internal references. Due to the symmetric resistor ladder inside the ADS930,  $V_{CM}$  is situated between the top and bottom reference voltage. The following equation can be used for calculating the common-mode voltage level:

$$V_{CM} = (REFT + REFB)/2 \quad (1)$$

## APPLICATIONS

### DRIVING THE ANALOG INPUTS

Figure 3 shows an example of an ac-coupled, single-ended interface circuit using high-speed op amps which operate on dual supplies (OPA650, OPA658). The mid-point reference voltage, ( $V_{CM}$ ), biases the bipolar, ground-referenced input

signal. The capacitor  $C_1$  and resistor  $R_1$  form a high-pass filter with the  $-3\text{dB}$  frequency set at

$$f_{-3\text{dB}} = 1/(2 \pi R_1 C_1) \quad (2)$$

The values for  $C_1$  and  $R_1$  are not critical in most applications and can be set freely. The values shown in Figure 3 correspond to a corner frequency of 1.6kHz.

Figure 4 depicts a circuit that can be used in single-supply applications. The mid-reference biases the op amp up to the appropriate common-mode voltage, for example  $V_{CM} = +1.5\text{V}$ . With the use of capacitor  $C_G$ , the DC gain for the non-inverting op amp input is set to  $+1\text{V/V}$ . As a result, the transfer function is modified to

$$V_{OUT} = V_{IN} \{(1 + R_F/R_G) + V_{CM}\} \quad (3)$$

Again, the input coupling capacitor  $C_1$  and resistor  $R_1$  form a high-pass filter. At the same time, the input impedance is defined by  $R_1$ . Resistor  $R_S$  isolates the op amp’s output from the capacitive load to avoid gain peaking or even oscillation. It can also be used to establish a defined bandwidth to reduce the wideband noise. Its value is usually between  $10\Omega$  and  $100\Omega$ .

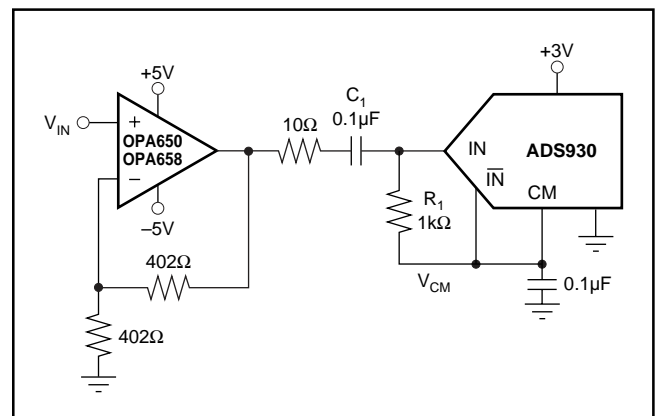

FIGURE 3. AC-Coupled Driver.

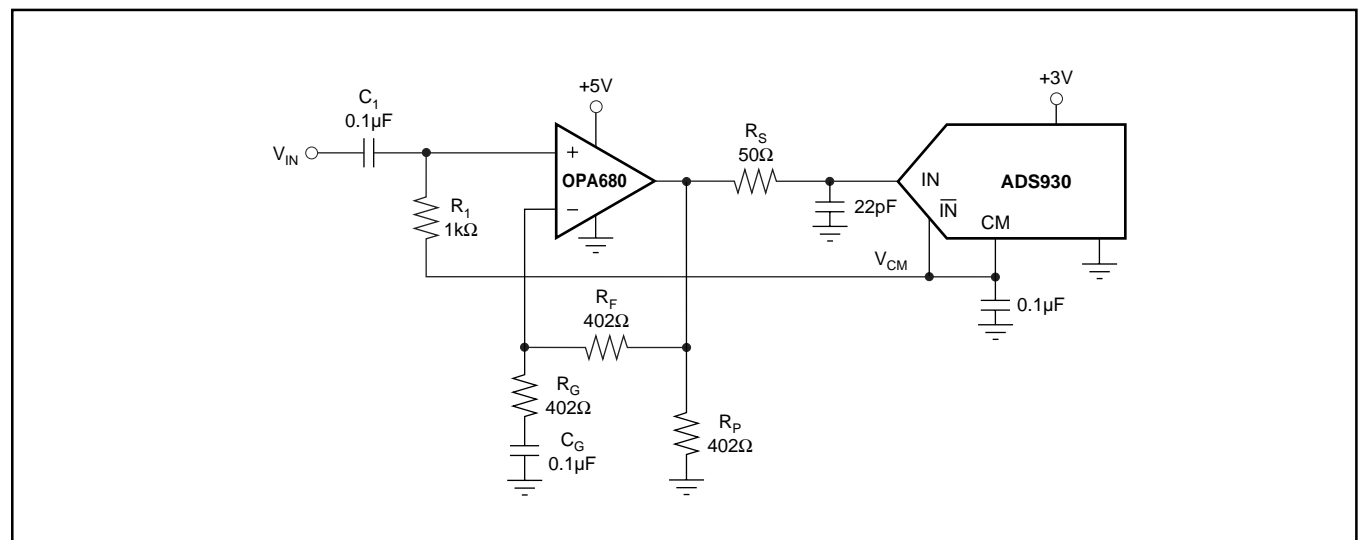

FIGURE 4. Interface Circuit Example Using the Voltage Feedback Amplifier OPA680.

## DC-COUPLED INTERFACE CIRCUIT

Figure 5 illustrates an example of a DC-coupled interface circuit using one high-speed op amp to level-shift the ground-referenced input signal. This serves to condition it for the input requirements of the ADS930. With a +3V supply the input signal swings 1Vp-p centered around a typical common-mode voltage of +1.5V. This voltage can be derived from the internal bottom reference (REFB) and then fed back through a resistor divider ( $R_1$ ,  $R_2$ ) to level-shift the driving op amp ( $A_1$ ). A capacitor across  $R_2$  will shunt most of the wideband noise to ground. Depending on the configured gain, the values of resistors  $R_1$  and  $R_2$  must be adjusted since the offsetting voltage ( $V_{OS}$ ) is amplified by the non-inverting gain,  $1 + (R_F/R_{IN})$ . This example assumes the sum of  $R_1$  and  $R_2$  to be  $5k\Omega$ , drawing only  $250\mu A$  from the bottom reference. Considerations for the selection of a proper op amp should include its output swing, input common-mode range, and bias current. This circuit can easily be modified for a +5V operation of the ADC, requiring a higher common-mode level (+2.5V).

## INTERNAL REFERENCE

The ADS930 features an internal reference that provides fixed reference voltages for the internal stages. As shown in

Figure 6, each end of the resistor ladder (REFT and REFB) are driven by a buffer amplifier. The ladder has a nominal resistance of  $4k\Omega$  ( $\pm 15\%$ ). The two outputs of the buffers are brought out at pin 21 (LpBy) and pin 25 (LnBy), primarily to connect external bypass capacitors, typically  $0.1\mu F$ . They will shunt the high frequency switching noise that is fed back into the reference circuit and improve the performance. The buffers can drive limited external loads, for example level-shifting of the converter's interface circuit. However, the current draw should be limited to approximately 1mA.

Derived from the top reference of +1.75V is an additional voltage of +1.0V. Note that this voltage, available on pin 23, is not buffered and care should be taken when external loads are applied. In normal operation, this pin is left unconnected and no bypassing components are required.

## CLOCK INPUT

The clock input of the ADS930 is designed to accommodate either +5V or +3V CMOS logic levels. To drive the clock input with a minimum amount of duty cycle variation and support the maximum sampling rate (30MSPS), high speed or advanced CMOS logic should be used (HC/HCT, AC/ACT). When digitizing at high sampling rates, a 50% duty cycle, along with fast rise and fall times (2ns or less),

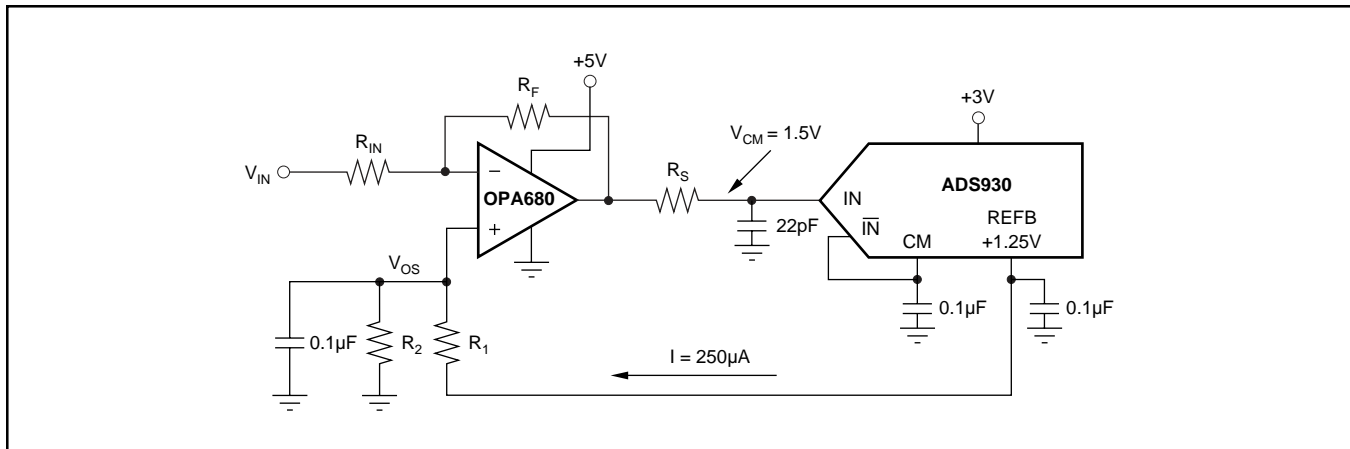

FIGURE 5. Single-supply, DC-coupled Interface Circuit.

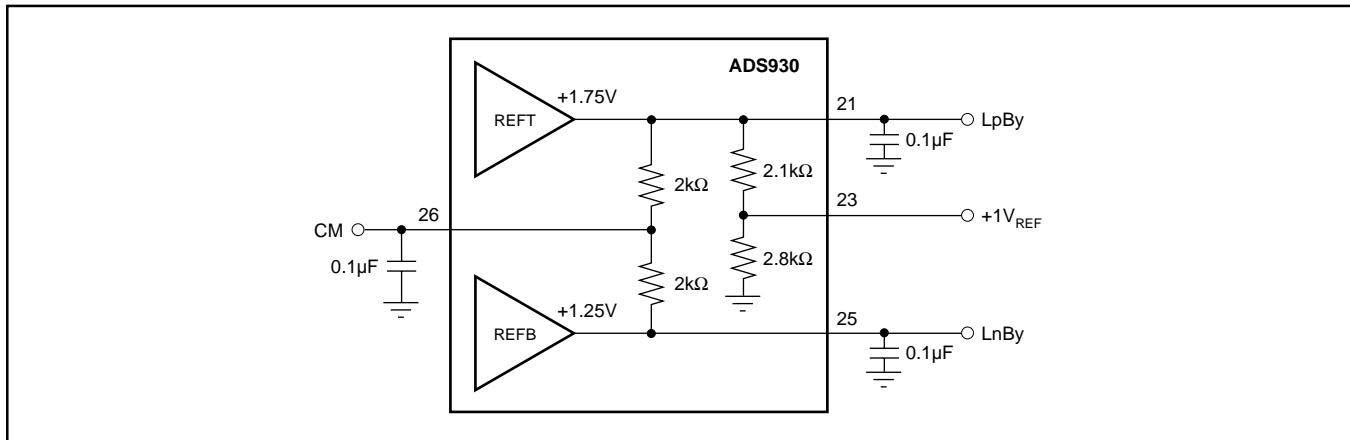

FIGURE 6. Internal Reference Structure and Recommended Reference Bypassing.

are recommended to meet the rated performance specifications. However, the ADS930 performance is tolerant to duty cycle variations of as much as  $\pm 10\%$ , which should not affect the performance. For applications operating with input frequencies up to Nyquist ( $f_{CLK}/2$ ) or undersampling applications, special considerations must be made to provide a clock with very low jitter. Clock jitter leads to aperture jitter ( $t_A$ ) which can be the ultimate limitation in achieving good SNR performance. The following equation shows the relationship between aperture jitter, input frequency and the signal-to-noise ratio:

$$SNR = 20 \log_{10} [1/(2 \pi f_{IN} t_A)] \quad (4)$$

SINGLE-ENDED INPUT ( $\overline{IN} = 1.5V$ DC)	STRAIGHT OFFSET BINARY (SOB) PIN 12 FLOATING or LO
+FS ( $IN = +2V$ )	11111111
+FS -1LSB	11111111
+FS -2LSB	11111110
+3/4 Full Scale	11100000
+1/2 Full Scale	11000000
+1/4 Full Scale	10100000
+1LSB	10000001
Bipolar Zero ( $IN +1.5V$ )	10000000
-1LSB	01111111
-1/4 Full Scale	01100000
-1/2 Full Scale	01000000
-3/4 Full Scale	00100000
-FS +1LSB	00000001
-FS ( $IN = +1V$ )	00000000

TABLE I. Coding Table for the ADS930.

## DIGITAL OUTPUTS

There is a 5.0 clock cycle data latency from the start convert signal to the valid output data. The standard output coding is Straight Offset Binary where a full scale input signal corresponds to all “1”s at the output. The digital outputs of the ADS930 can be set to a high impedance state by driving the  $\overline{OE}$  (pin 16) with a logic “HI”. Normal operation is achieved with pin 16 “LO” or Floating due to internal pull-down resistors. This function is provided for testability purposes but is not recommended to be used dynamically.

The digital outputs of the ADS930 are standard CMOS stages and designed to be compatible to both high speed TTL and CMOS logic families. The logic thresholds are for low-voltage CMOS:  $V_{OL} = 0.4V$ ,  $V_{OH} = 2.4V$ , which allows the ADS930 to directly interface to 3V-logic. The digital output driver of the ADS930 uses a dedicated digital supply pin (pin 2,  $LV_{DD}$ ) see Figure 7. By adjusting the voltage on

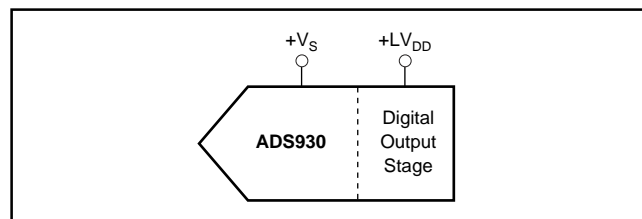

FIGURE 7. Independent Supply Connection for Output Stage.

$LV_{DD}$ , the digital output levels will vary respectively. It is recommended to limit the fan-out to one in order to keep the capacitive loading on the data lines below the specified 15pF. If necessary, external buffers or latches may be used to provide the added benefit of isolating the ADC from any digital activities on the bus coupling back high frequency noise which degrades the performance.

## POWER-DOWN MODE

The ADS930's low power consumption can be reduced even further by initiating a power-down mode. For this, the Power Down Pin (Pin 17) must be tied to a logic “High” reducing the current drawn from the supply by approximately 70%. In normal operation, the power-down mode is disabled by an internal pull-down resistor (50k $\Omega$ ).

During power-down, the digital outputs are set in 3-state. With the clock applied, the converter does not accurately process the sampled signal. After removing the power-down condition, the output data from the following 5 clock cycles is invalid (data latency).

## DECOUPLING AND GROUNDING CONSIDERATIONS

The ADS930 has several supply pins, one of which is dedicated to supply only the output driver ( $LV_{DD}$ ). The remaining supply pins are not divided into analog and digital supply pins since they are internally connected on the chip. For this reason, it is recommended that the converter be treated as an analog component and to power it from the analog supply only. Digital supply lines often carry high levels of noise which can couple back into the converter and limit performance.

Because of the pipeline architecture, the converter also generates high frequency transients and noise that are fed back into the supply and reference lines. This requires that the supply and reference pins be sufficiently bypassed. Figure 8 shows the recommended decoupling scheme for the analog supplies. In most cases 0.1 $\mu$ F ceramic chip capacitors are adequate to keep the impedance low over a wide frequency range. Their effectiveness largely depends on the proximity to the individual supply pin. Therefore, they should be located as close as possible to the supply pins.

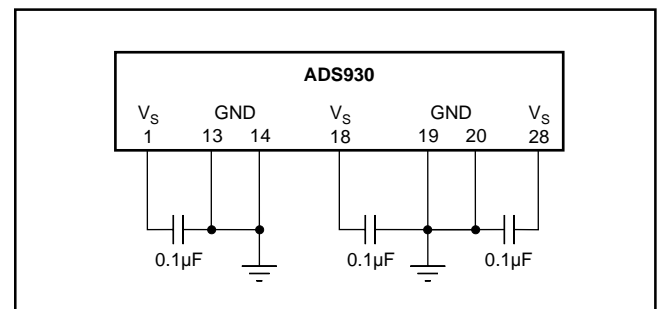

FIGURE 8. Recommended Bypassing for Analog Supply Pins.

**PACKAGING INFORMATION**

Orderable Device	Status (1)	Package Type	Package Drawing	Pins	Package Qty	Eco Plan (2)	Lead finish/ Ball material (6)	MSL Peak Temp (3)	Op Temp (°C)	Device Marking (4/5)	Samples
ADS930E	ACTIVE	SSOP	DB	28	50	RoHS & Green	NIPDAU	Level-2-260C-1 YEAR	-40 to 85	ADS930E	<a href="#">Samples</a>
ADS930E/1K	ACTIVE	SSOP	DB	28	1000	RoHS & Green	NIPDAU	Level-1-260C-UNLIM	-40 to 85	ADS930E	<a href="#">Samples</a>

(1) The marketing status values are defined as follows:

**ACTIVE:** Product device recommended for new designs.

**LIFEBUY:** TI has announced that the device will be discontinued, and a lifetime-buy period is in effect.

**NRND:** Not recommended for new designs. Device is in production to support existing customers, but TI does not recommend using this part in a new design.

**PREVIEW:** Device has been announced but is not in production. Samples may or may not be available.

**OBSOLETE:** TI has discontinued the production of the device.

(2) **RoHS:** TI defines "RoHS" to mean semiconductor products that are compliant with the current EU RoHS requirements for all 10 RoHS substances, including the requirement that RoHS substance do not exceed 0.1% by weight in homogeneous materials. Where designed to be soldered at high temperatures, "RoHS" products are suitable for use in specified lead-free processes. TI may reference these types of products as "Pb-Free".

**RoHS Exempt:** TI defines "RoHS Exempt" to mean products that contain lead but are compliant with EU RoHS pursuant to a specific EU RoHS exemption.

**Green:** TI defines "Green" to mean the content of Chlorine (Cl) and Bromine (Br) based flame retardants meet JS709B low halogen requirements of <=1000ppm threshold. Antimony trioxide based flame retardants must also meet the <=1000ppm threshold requirement.

(3) MSL, Peak Temp. - The Moisture Sensitivity Level rating according to the JEDEC industry standard classifications, and peak solder temperature.

(4) There may be additional marking, which relates to the logo, the lot trace code information, or the environmental category on the device.

(5) Multiple Device Markings will be inside parentheses. Only one Device Marking contained in parentheses and separated by a "~" will appear on a device. If a line is indented then it is a continuation of the previous line and the two combined represent the entire Device Marking for that device.

(6) Lead finish/Ball material - Orderable Devices may have multiple material finish options. Finish options are separated by a vertical ruled line. Lead finish/Ball material values may wrap to two lines if the finish value exceeds the maximum column width.

**Important Information and Disclaimer:**The information provided on this page represents TI's knowledge and belief as of the date that it is provided. TI bases its knowledge and belief on information provided by third parties, and makes no representation or warranty as to the accuracy of such information. Efforts are underway to better integrate information from third parties. TI has taken and continues to take reasonable steps to provide representative and accurate information but may not have conducted destructive testing or chemical analysis on incoming materials and chemicals. TI and TI suppliers consider certain information to be proprietary, and thus CAS numbers and other limited information may not be available for release.

In no event shall TI's liability arising out of such information exceed the total purchase price of the TI part(s) at issue in this document sold by TI to Customer on an annual basis.



**TUBE**

\*All dimensions are nominal

Device	Package Name	Package Type	Pins	SPQ	L (mm)	W (mm)	T (μm)	B (mm)
ADS930E	DB	SSOP	28	50	530	10.5	4000	4.1

## IMPORTANT NOTICE AND DISCLAIMER

TI PROVIDES TECHNICAL AND RELIABILITY DATA (INCLUDING DATA SHEETS), DESIGN RESOURCES (INCLUDING REFERENCE DESIGNS), APPLICATION OR OTHER DESIGN ADVICE, WEB TOOLS, SAFETY INFORMATION, AND OTHER RESOURCES "AS IS" AND WITH ALL FAULTS, AND DISCLAIMS ALL WARRANTIES, EXPRESS AND IMPLIED, INCLUDING WITHOUT LIMITATION ANY IMPLIED WARRANTIES OF MERCHANTABILITY, FITNESS FOR A PARTICULAR PURPOSE OR NON-INFRINGEMENT OF THIRD PARTY INTELLECTUAL PROPERTY RIGHTS.

These resources are intended for skilled developers designing with TI products. You are solely responsible for (1) selecting the appropriate TI products for your application, (2) designing, validating and testing your application, and (3) ensuring your application meets applicable standards, and any other safety, security, regulatory or other requirements.

These resources are subject to change without notice. TI grants you permission to use these resources only for development of an application that uses the TI products described in the resource. Other reproduction and display of these resources is prohibited. No license is granted to any other TI intellectual property right or to any third party intellectual property right. TI disclaims responsibility for, and you will fully indemnify TI and its representatives against, any claims, damages, costs, losses, and liabilities arising out of your use of these resources.

TI's products are provided subject to [TI's Terms of Sale](#) or other applicable terms available either on [ti.com](http://ti.com) or provided in conjunction with such TI products. TI's provision of these resources does not expand or otherwise alter TI's applicable warranties or warranty disclaimers for TI products.

TI objects to and rejects any additional or different terms you may have proposed.

Mailing Address: Texas Instruments, Post Office Box 655303, Dallas, Texas 75265  
Copyright © 2022, Texas Instruments Incorporated