

SECTION Z-Z

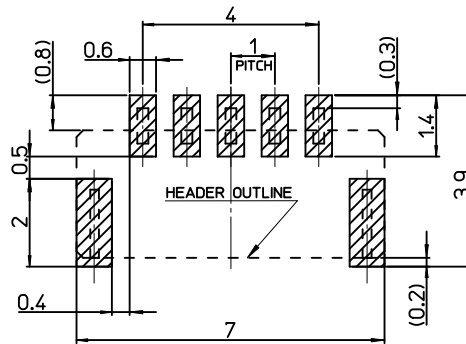

RECOMMENDED PCB LAY OUT

[GENERAL TOLERANCE ±0.05]

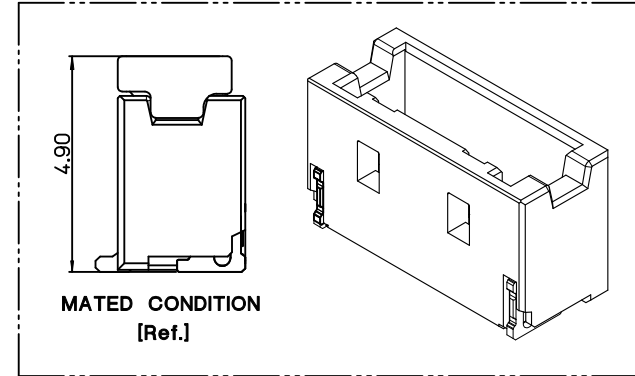

MATED CONDITION [Ref.]

NOTE.

- MATED WITH : 104128-0500
- MATERIALS
 - ① HEADER : LIQUID CRYSTAL POLYMER (LCP), GLASS FILLED, UL94V-0
COLOR : NATURAL COLOR
 - ② CONTACT TERMINAL : PHOSPHOR BRONZE
 - ③ FITTING NAIL : PHOSPHOR BRONZE
- FINISHES
 - ② CONTACT TERMINAL : PURE-TIN PLATING ON OVERALL. THICKNESS 3.0μm MINIMUM UNDER PLATING Ni OVERALL. THICKNESS 1.25μm MINIMUM
 - ③ FITTING NAIL : PURE-TIN PLATING ON OVERALL. THICKNESS 3.0μm MINIMUM UNDER PLATING Ni OVERALL. THICKNESS 1.25μm MINIMUM
- PRODUCT SPECIFICATION : PS-104127-002
- PACKAGING SPECIFICATION : PK-104127-002
- COPLANALITH OF SOLDER TAIL (PEAK TEMP. : 260°C) BEFORE & AFTER REFLOW : 0.08MAX

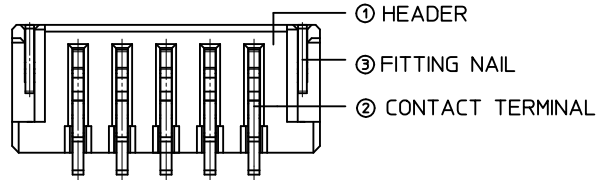
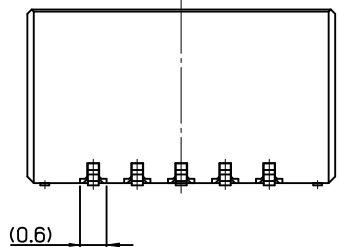
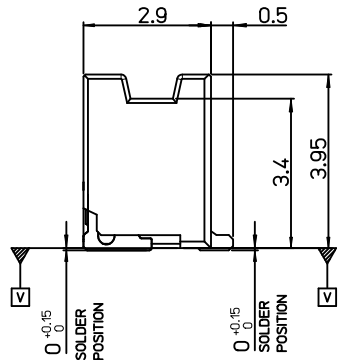
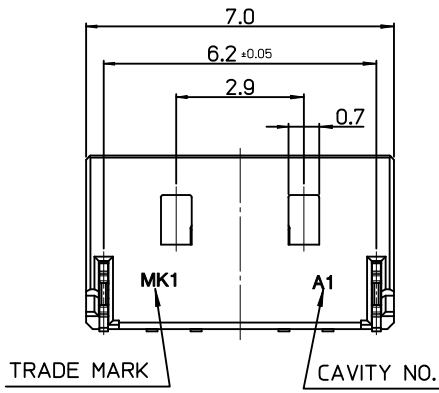

RELEASED
EC NO: 2012/02/24
DRWN: JHPARK01
CHKD:
APPR:

QUALITY SYMBOLS
=0
=0
DESCRIPTION
REV

GENERAL TOLERANCES (UNLESS SPECIFIED)	
mm	INCH
4 PLACES ± ---	± ---
3 PLACES ± 0.005	± ---
2 PLACES ± 0.05	± ---
1 PLACE ± 0.1	± ---
ANGULAR ± 1 °	
DRAFT WHERE APPLICABLE MUST REMAIN WITHIN DIMENSIONS	

DIMENSION STYLE	
MM ONLY	
DRAWN BY	DATE
JHPARK01	2012/02/24
CHECKED BY	DATE
APPROVED BY	DATE
MATERIAL NO.	
SEE TABLE	
SIZE	A3

SCALE	4/1	DESIGN UNITS	METRIC	THIRD ANGLE PROJECTION
TITLE				
1.0MM WTB CONN.-5P HEADER ASS'Y				
MOLEX INCORPORATED				
DOCUMENT NO.				SHEET NO.
SD-104127-002				1 OF 01

THIS DRAWING CONTAINS INFORMATION THAT IS PROPRIETARY TO MOLEX INCORPORATED AND SHOULD NOT BE USED WITHOUT WRITTEN PERMISSION

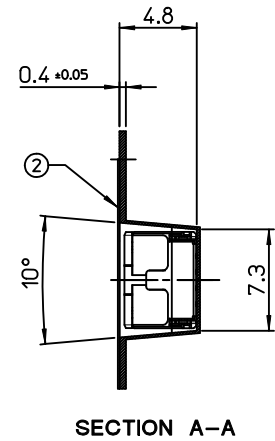
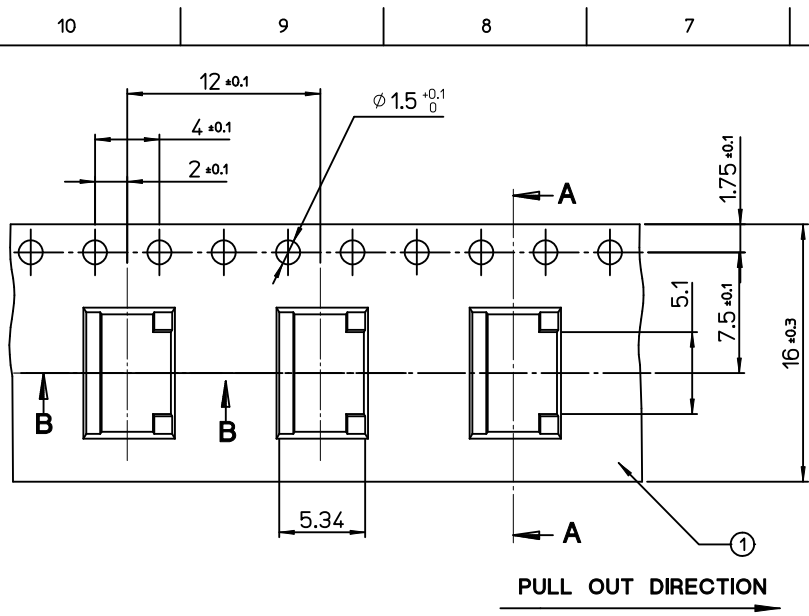

SECTION A-A

PULL OUT DIRECTION

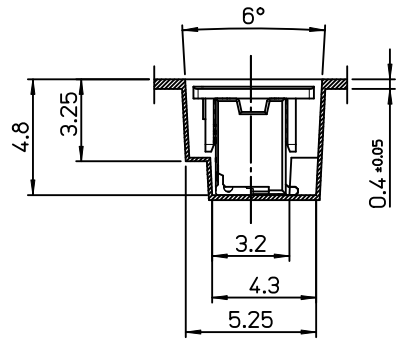
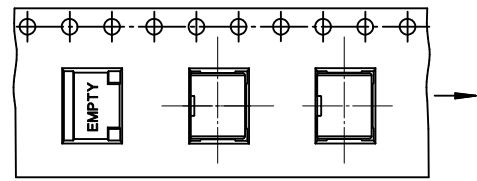

SECTION B-B

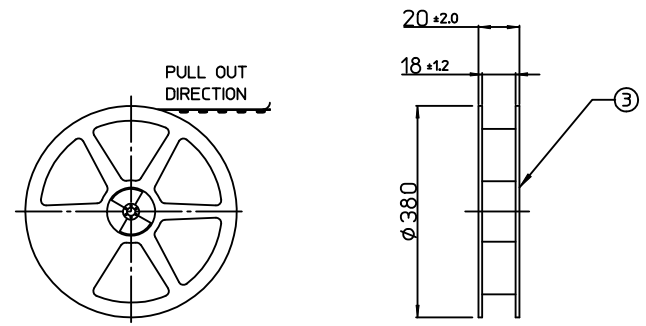

PLASTIC BOBBIN

NOTES

1. QUANTITY OF CONNECTORS : 1,500 PCS/REEL
2. LEAD LENGTH
3. PEELING OFF FORCE OF COVER TAPE : 0.1N~0.59N(10.20GF~60GF)
 (PEELING DIRECTION AS SHOW IN FOLLOW FIG.)
 PEELING OFF SPEED : 300mm/Min.(Ref.)

4. FLASH IN ANY PORTION SHOULD BE LESS THAN 0.20mm MAX.
5. UNLESS OTHERWISE SPECIFIED INNER R0.2 MAX
6. DRAFT ANGLE 3°MAX

3	PLASTIC BOBBIN	HI P.S	WHITE
2	COVER TAPE	PET ANTISTATIC	13.3m
1	CARRIER (EMBOSSD) TAPE	PET ANTISTATIC	16.0m
NO.	DESCRIPTION	MATERIAL	REMARK

ORDER NO 104127-0510

RELEASED EC NO: KOR2012-0092 DRWN: JHPARK01 2012/03/07 CHKD: APPR: YSKIM02 2012/03/16 REV A	QUALITY SYMBOLS ▽=0 ▽=0	GENERAL TOLERANCES (UNLESS SPECIFIED)		DIMENSION STYLE MM ONLY		SCALE	DESIGN UNITS	THIRD ANGLE PROJECTION
		mm	INCH	DRAWN BY	DATE	TITLE	METRIC	
		4 PLACES ± ---	± ---	JHPARK01	2012/02/24	EMBOSSD PACKAGE 1.0 WTB CONN. HEADER ASS'Y-5P		
		3 PLACES ± ---	± ---	CHECKED BY	DATE			
		2 PLACES ± 0.15	± ---	SHCHU	2012/02/24			
		1 PLACE ± 0.20	± ---	APPROVED BY	DATE			
		ANGULAR ± 1 °		YSKIM02	2012/03/16			
		DRAFT WHERE APPLICABLE MUST REMAIN WITHIN DIMENSIONS		MATERIAL NO.				
				SEE TABLE				
				SIZE A3	THIS DRAWING CONTAINS INFORMATION THAT IS PROPRIETARY TO MOLEX INCORPORATED AND SHOULD NOT BE USED WITHOUT WRITTEN PERMISSION			



MOLEX INCORPORATED

SD-104127-003

SHEET NO. 1 OF 1