



RVT70HSTFWN00

## IPS RGB 7.0" LCD TFT DATASHEET

Rev.1.2

2021-07-29

ITEM	CONTENTS	UNIT
LCD Type	TFT/Transmissive/Normally black/IPS	/
Size	7.0	Inch
Viewing Direction	Free	/
Outside Dimensions (W x H x D)	181.60 x 100.60 x 6.23	mm
Active Area (W x H)	154.21 x 85.92	mm
Pixel Pitch (W x H)	0.1506 x 0.1432	mm
Resolution	1024 (RGB) x 600	/
Brightness	1000	cd/m <sup>2</sup>
LCD Interface Type	RGB	/
Color Depth	16.7 M	/
Pixel Arrangement	RGB Vertical Stripe	/
With/Without Touch	Without Touch Panel	/
Weight	177	g

Note 1: RoHS3 compliant

Note 2: LCM weight tolerance:  $\pm 5\%$ .



## 1. REVISION RECORD

REV NO.	REV DATE	CONTENTS	REMARKS
1.0	2020-08-05	Initial Release	
1.1	2021-04-20	Add" inch" unit on drawing	
1.2	2021-07-29	Updating new template	



## 2. CONTENTS

1.	REVISION RECORD.....	2
2.	CONTENTS.....	3
3.	MODULE CLASSIFICATION INFORMATION.....	4
4.	ASSEMBLY GUIDE.....	5
4.1	Mounting frame.....	5
5.	MODULE DRAWING.....	6
6.	ABSOLUTE MAXIMUM RATINGS.....	7
7.	ELECTRICAL CHARACTERISTICS.....	7
8.	BACKLIGHT ELECTRICAL CHARACTERISTICS.....	7
9.	POWER CONSUMPTION.....	8
10.	ELECTRO-OPTICAL CHARACTERISTICS.....	9
11.	BLOCK DIAGRAM.....	11
12.	INTERFACES DESCRIPTION.....	12
12.1	TFT assignment.....	12
13.	TIMING CHARACTERISTICS.....	14
13.1	Horizontal input timing.....	14
13.2	Vertical input timing.....	14
13.3	Parallel RGB timing characteristic.....	15
13.3.1	DE MODE.....	15
13.3.2	HV MODE – Horizontal input timing.....	15
13.3.3	HV MODE – Vertical input timing.....	15
13.3.4	Power On/Off sequence.....	16
14.	INSPECTION.....	16
14.1	Inspection condition.....	16
14.2	Inspection standard.....	17
15.	RELIABILITY TEST.....	18
16.	LEGAL INFORMATION.....	19



### 3. MODULE CLASSIFICATION INFORMATION

RV	T	70	H	S	T	F	W	N	00
1.	2.	3.	4.	5.	6.	7.	8.	9.	10.

NO.	PARAMETER	SYMBOL
1.	BRAND	RV – Riverdi
2.	PRODUCT TYPE	T – TFT Standard
3.	DISPLAY SIZE	70 – 7.0”
4.	MODEL SERIAL NO.	H – High Brightness, IPS
5.	RESOLUTION	S – 1024 x 600 px
6.	INTERFACE	T – TFT LCD, RGB
7.	FRAME	F – With Mounting Metal Frame
8.	BACKLIGHT TYPE	W – LED White
9.	TOUCH PANEL	N – Without Touch Panel
10.	VERSION	00 – (00-99)

## 4. ASSEMBLY GUIDE

### 4.1 Mounting frame

For dimensions 3.5", 4.3", 5.0", 7.0" and 10.1" the product with mounting frame version is available. Thanks to the four catches attached to the side, frame provides strong assembly to the surface by mounting element (like the screw, see Figure 1). The frames are specially designed to fit Riverdi products perfectly. The diameter of the mounting hole is 3.5mm.

*Figure 1. Mounting frame*

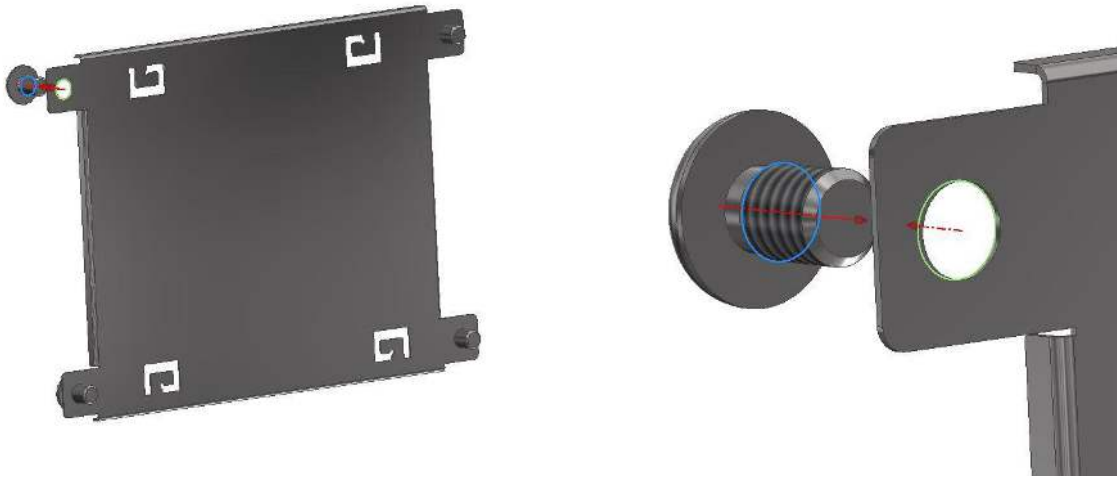

Revision:	Changes:	Date:
1.0	Initial Case	2020.06.03
1.1	Dimension Overhaul	2021.04.19

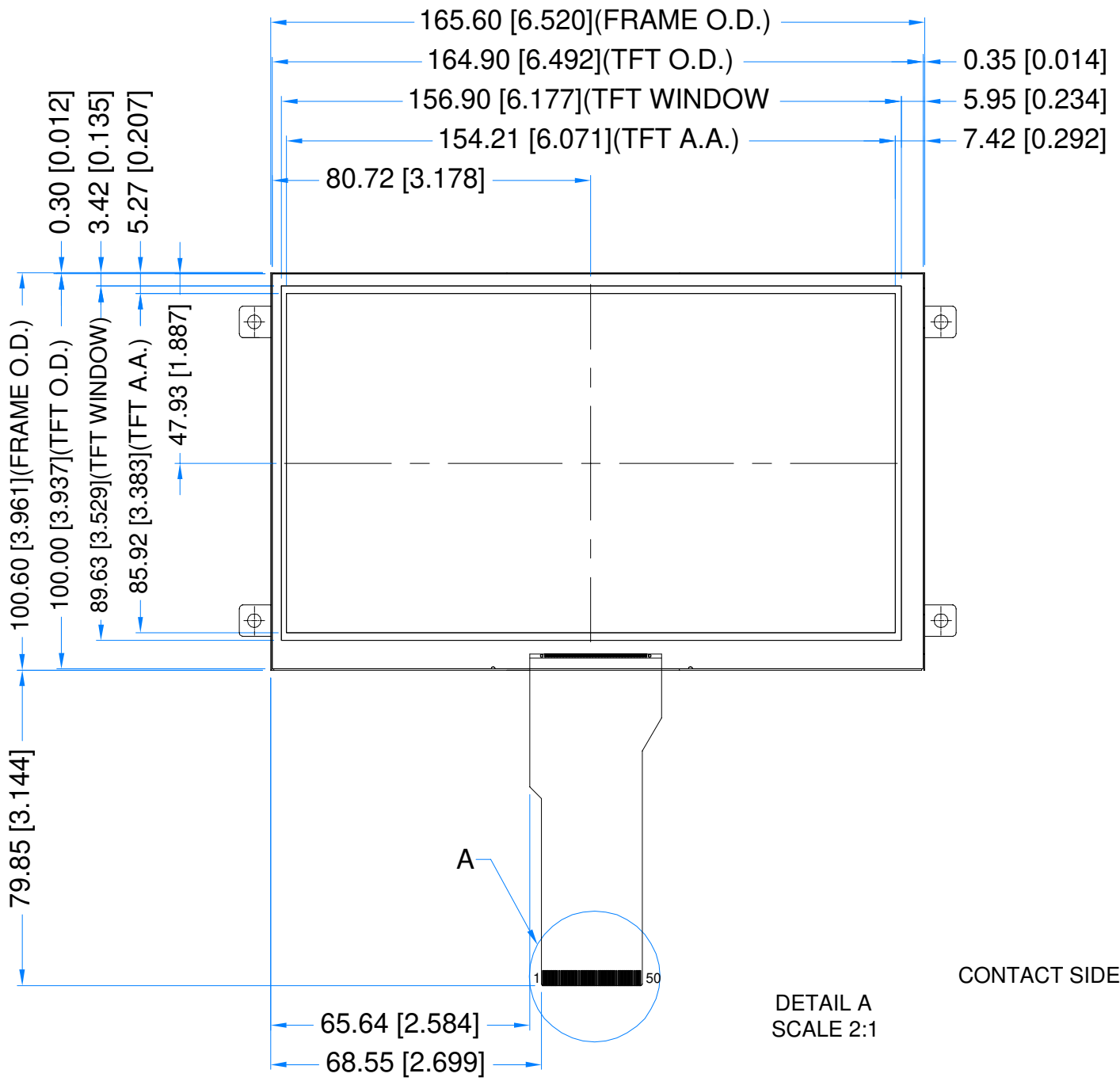

- 6.23 [0.245] (MODULE O.D.)
- 5.93 [0.233] (MOUNTING DEPTH)
- 5.70 [0.224] (TFT O.D.)

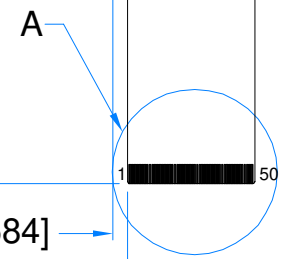
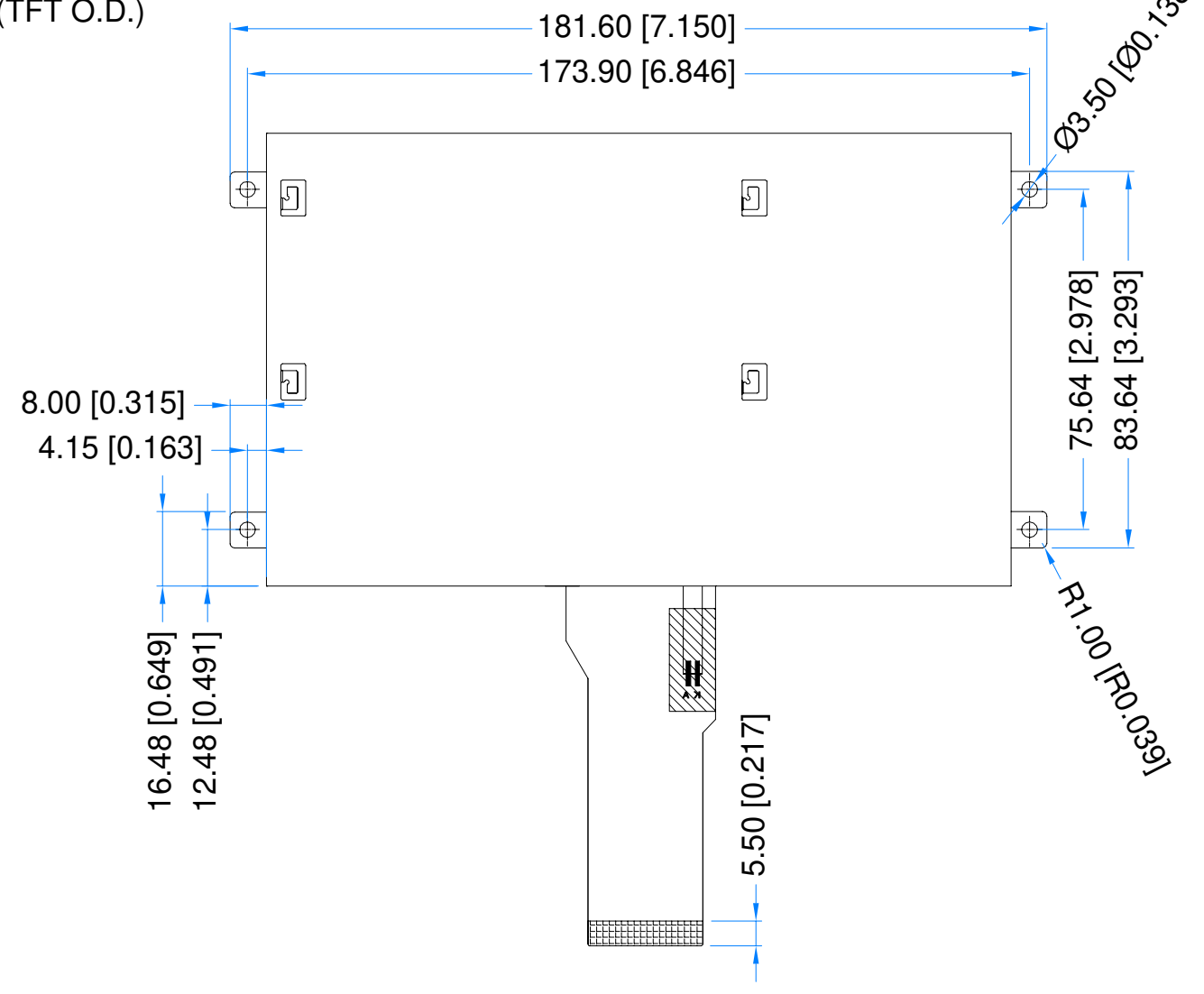

DETAIL A  
SCALE 2:1

CONTACT SIDE      STIFFENER  
0.30 [0.012]

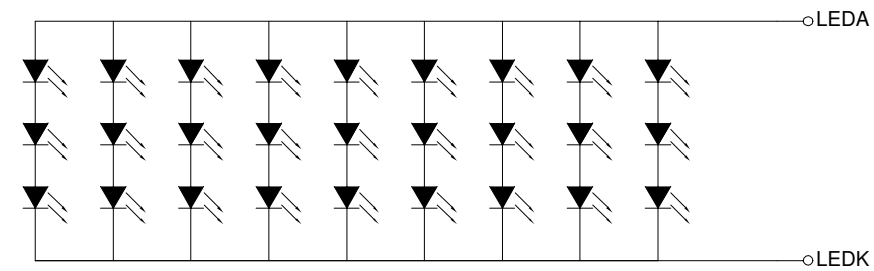
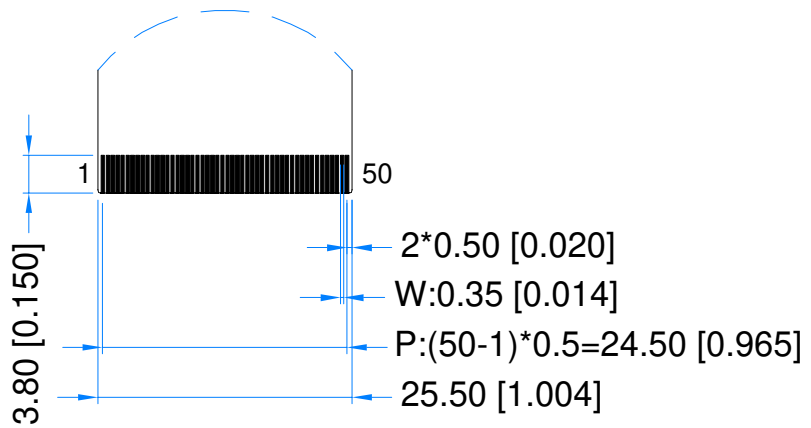

LED Diagram Circuit

**TFT NOTES:**  
1. LCD TYPE: TRANSMISSIVE, NORMALLY BLACK, IPS  
2. RESOLUTION: 1024x600  
3. VIEWING ANGLE: FREE  
4. INTERFACE: RGB  
5. LCD DRIVER: EK79001HK+EK73215BCGA  
6. LOGIC VOLTAGE: 3.3V  
7. SURFACE LUMINANCE: 1000cd/m<sup>2</sup>  
8. BACKLIGHT: 27PCS LED, V<sub>F</sub>=9.6V, I<sub>F</sub>=270mA

**GENERAL NOTES:**  
1. OPERATING TEMPERATURE: -20°C ~ 70°C  
2. STORAGE TEMPERATURE: -30°C ~ 80°C  
3. MOUNTING METAL FRAME THICKNESS: 0.3mm  
4. WITHOUT INDIVIDUAL TOLERANCE: ±0.2mm  
5. RoHS3 COMPLIANT

PN: RVT70HSTFWN00			
SN:			
DRAWN: M.Natywa	2021.04.19	1:1.52	
CHECKED: Carol	2021.04.20	[mm]	
APPR:			
		ISO A3	P. 1 of 1



## 6. ABSOLUTE MAXIMUM RATINGS

PARAMETER	SYMBOL	MIN	MAX	UNIT
Power for Circuit Driving	VDD	-0.3	3.96	V
	AVDD	-0.5	14.85	
	VGH	-0.3	40	
	VGL	-20.0	0.3	
Operating Temperature	T <sub>OP</sub>	-20	70	°C
Storage Temperature	T <sub>ST</sub>	-30	80	°C
Operating Humidity (@ 25 ± 5°C)	RH	10%	-	RH
Storage Humidity (@ 25 ± 5°C)	RH	10%	-	RH

**Note.** The following are maximum values. If exceeded, it may cause operation or damage to the unit.

## 7. ELECTRICAL CHARACTERISTICS

PARAMETER	SYMBOL	MIN	TYP	MAX	UNIT	NOTE
Supply Voltage for Module	DVDD	3.0	3.3	3.6	V	
	VGH	17	18	19		
	VGL	-6.6	-6.0	-5.4		
	AVDD	9.4	9.6	9.8		
	VCOM	3.6	3.8	4.0		
Current of Power Supply	IDD	-	30	45	mA	DVDD = 3.3V
	IADD	-	35	45	mA	AVDD = 9.6V
	IGH	-	0.5	1	uA	VGH = 18V
	IGL	-	0.5	1	mA	VGL = -6V
Input Voltage ' H ' level	V <sub>IH</sub>	0.7DVDD	-	DVDD	V	Note 1
Input Voltage ' L ' level	V <sub>IL</sub>	0	-	0.3VDD	V	Note 1

**Note 1.** STHL, STHR, OEH, L/R, CPH1÷CPH3, STVD, STVU, OEV, CKV, U/D.

## 8. BACKLIGHT ELECTRICAL CHARACTERISTICS

PARAMETER	SYMBOL	MIN	TYP	MAX	UNIT	NOTE
Backlight Driving Voltage	V <sub>F</sub>	9.0	9.6	10.2	V	
Backlight Driving Current	I <sub>F</sub>	-	270	-	mA	
Backlight Power Consumption	W <sub>BL</sub>	-	2592	-	mW	
LED Lifetime	-	-	50,000	-	hours	Note 1

**Note 1.** If LED is driven by high current, the lifetime of LED will be reduced. Operating life means brightness goes down to 50% initial brightness. Typical operating lifetime is estimated data.

## 9. POWER CONSUMPTION

PARAMETER	SYMBOL	CONDITION	MIN	TYP	MAX	UNIT	NOTE
Gate on Power Current	IVGH	VGH=18V	-	0.5	1	mA	Note 1
Gate off Power Current	IVGL	VGL=6V	-	0.5	1		
Digital Power Current	IDVDD	DVDD=3.3V	-	30	45		
Analog Power Current	I <sub>AVDD</sub>	AVDD=9.6 V	-	35	45		
Total Power Consumption	PC		-	447	604	mW	

**Note.** Typ. Specification: Gray-level test pattern; Max Specification: Black test pattern



256 gray patten



black pattern





## 10. ELECTRO-OPTICAL CHARACTERISTICS

ITEM	SYMBOL	CONDITION	MIN	TYP	MAX	UNIT	RMK	NOTE
Response Time	Tr+Tf	$\theta=0^\circ$ $\varnothing=0^\circ$ Ta=25 °C	-	35	-	ms	FIG 2.	4
Contrast Ratio	Cr		-	800	-	---	FIG 3.	1
Luminance Uniformity	$\delta$ WHITE		-	75	-	%	FIG 3.	3
Surface Luminance	Lv		800	1000	-	cd/m <sup>2</sup>	FIG 3.	2
Viewing Angle Range	$\theta$	$\varnothing = 90^\circ$	-	85	-	deg	FIG 4.	6
		$\varnothing = 270^\circ$	-	85	-	deg	FIG 4.	
		$\varnothing = 0^\circ$	-	85	-	deg	FIG 4.	
		$\varnothing = 180^\circ$	-	85	-	deg	FIG 4.	
CIE (x, y) Chromaticity	Rx	$\theta=0^\circ$ $\varnothing=0^\circ$ Ta=25 °C	0.578	0.618	0.658	-	FIG 3.	5
	Ry		0.489	0.329	0.369	-		
	Gx		0.376	0.416	0.456	-		
	Gy		0.493	0.533	0.573	-		
	Bx		0.071	0.111	0.151	-		
	By		0.108	0.148	0.188	-		
	Wx		0.270	0.310	0.350	-		
	Wy		0.290	0.330	0.370	-		

**Note 1.** Contrast Ratio (CR) is defined mathematically as below, for more information see Figure 3.

$$\text{Contrast Ratio} = \frac{\text{Average Surface Luminance with all white pixels (P1, P2, P3, P4, P5)}}{\text{Average Surface Luminance with all black pixels (P1, P2, P3, P4, P5)}}$$

**Note 2.** Surface luminance is the LCD surface from the surface with all pixels displaying white. For more information see

Figure 3.

$$L_v = \text{Average Surface Luminance with all white pixels (P1, P2, P3, P4, P5)}$$

**Note 3.** The uniformity in surface luminance  $\delta$  WHITE is determined by measuring luminance at each test position 1 through 5, and then dividing the minimum luminance of 5 points luminance by maximum luminance of 5 points luminance. For more information see

Figure 3.

$$\delta \text{ WHITE} = \frac{\text{Minimum Surface Luminance with all white pixels (P1, P2, P3, P4, P5)}}{\text{Maximum Surface Luminance with all white pixels (P1, P2, P3, P4, P5)}}$$

**Note 4.** Response time is the time required for the display to transition from white to black (Rise Time, Tr) and from black to white (Decay Time, Tf). For additional information see Figure 2. The test equipment is Autronic-Melchers's ConoScope series.

**Note 5.** CIE (x, y) chromaticity, the x, y value is determined by measuring luminance at each test position 1 through 5, and then make average value.

**Note 6.** Viewing angle is the angle at which the contrast ratio is greater than 2. For TFT module the contrast ratio is greater than 10. The angles are determined for the horizontal

or x axis and the vertical or y axis with respect to the z axis which is normal to LCD surface. For more information see Figure 4.

**Note 7.** For viewing angle and response time testing, the testing data is based on Autronic-Melchers's ConoScope series. Instruments for Contrast Ratio, Surface Luminance, Luminance Uniformity, CIE the test data is based on TOPCON's BM-5 photo detector.

Figure 2. The definition of response time

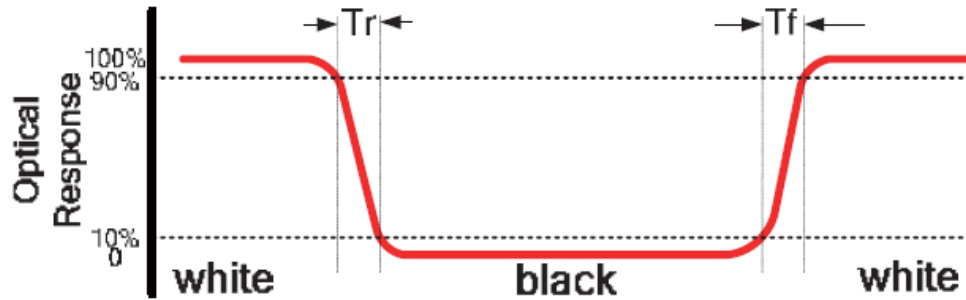
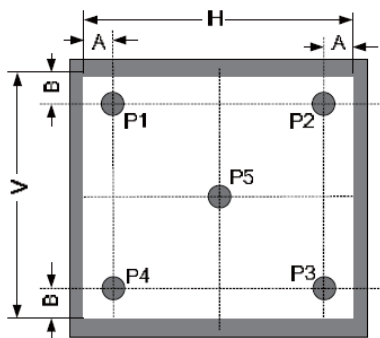

Figure 3. Measuring method for Contrast ratio, surface luminance, Luminance uniformity, CIE (x, y) chromaticity



A: 5mm

B: 5mm

H, V: Active Area

Light spot size  $\phi=5\text{mm}$ , 500mm distance from the LCD surface to detector lens.

Measurement instrument is TOPCON'S luminance meter BM-5

Figure 4. The definition of viewing angle

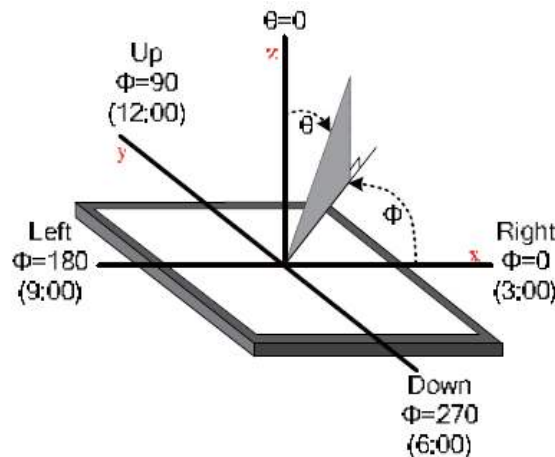



## 11. BLOCK DIAGRAM

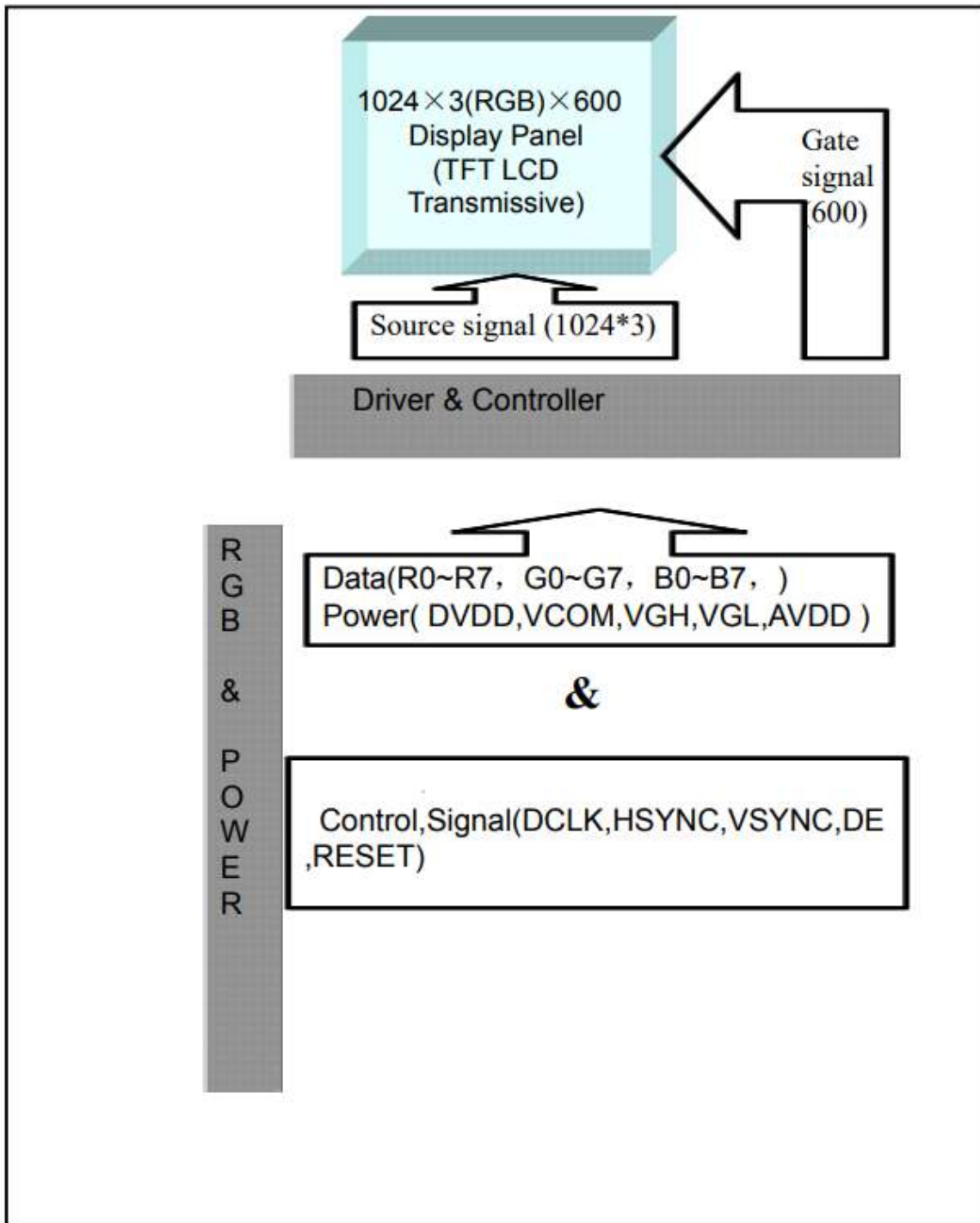



## 12. INTERFACES DESCRIPTION

### 12.1 TFT assignment

PIN NO.	SYMBOL	I/O	DESCRIPTION	NOTES
1	VLED+	P	Power for LED Backlight (Anode)	
2	VLED+	P	Power for LED Backlight (Anode)	
3	VLED-	P	Power for LED Backlight (Cathode)	
4	VLED-	P	Power for LED Backlight (Cathode)	
5	GND	P	Ground	
6	VCOM	I	Common Voltage	
7	DVDD	P	Power for Digital Circuit	
8	MODE	I	DE/SYNC mode select	Note 1
9	DE	I	Data Input Enable	
10	VS	I	Vertical Sync Input	
11	HS	I	Horizontal Sync Input	
12	B7	I	Blue Data (MSB)	
13	B6	I	Blue Data	
14	B5	I	Blue Data	
15	B4	I	Blue Data	
16	B3	I	Blue Data	
17	B2	I	Blue Data	
18	B1	I	Blue Data	Note 2
19	B0	I	Blue Data (LSB)	Note 2
20	G7	I	Green Data (MSB)	
21	G6	I	Green Data	
22	G5	I	Green Data	
23	G4	I	Green Data	
24	G3	I	Green Data	
25	G2	I	Green Data	
26	G1	I	Green Data	Note 2
27	G0	I	Green Data (LSB)	Note 2
28	R7	I	Red Data (MSB)	
29	R6	I	Red Data	
30	R5	I	Red Data	
31	R4	I	Red Data	
32	R3	I	Red Data	
33	R2	I	Red Data	
34	R1	I	Red Data	Note 2
35	R0	I	Red Data(LSB)	Note 2
36	GND	P	Ground	
37	DCLK	P	Sample Clock	
38	GND	P	Ground	
39	L/R	I	Left/Right Selection	Note 4,5
40	U/D	I	Up/Down Selection	Note 4,5
41	VGH	P	Gate ON Voltage	
42	VGL	P	Gate OFF Voltage	



43	AVDD	P	Power for Analog Circuit	
44	RESET	I	Global Reset Pin	Note 6
45	NC	-	No Connection	
46	VCOM	I	Common Voltage	
47	DITHUB	I	Dithering Function	Note 7
48	GND	I	Ground	
49	NC	-	No Connection	
50	NC	-	No Connection	

I: input, O: output, P:Power

**Note 1.** DE/SYNC mode select. Normally pull high.

H:DE Mode. L: HS/VS mode.

When select DE mode, MODE="1", VS and HS must pull high.

**Note 2.** When input 18 bits RGB data, the two low bits of R, G and B data must be grounded.

**Note 3.** Data shall be latched at the falling edge of DCLK.

**Note 4.** Selection of scanning mode:

SETTING OF SCAN CONTROL INPUT		SCANNING DIRECTION
U/D	L/R	
GND	DVDD	Up to down, left to right
DVDD	GND	Down to up, right to left
GND	GND	Up to down, right to left
DVDD	DVDD	Down to up, left to right

**Note 5.** Definition of scanning direction, refer to the figure as below:

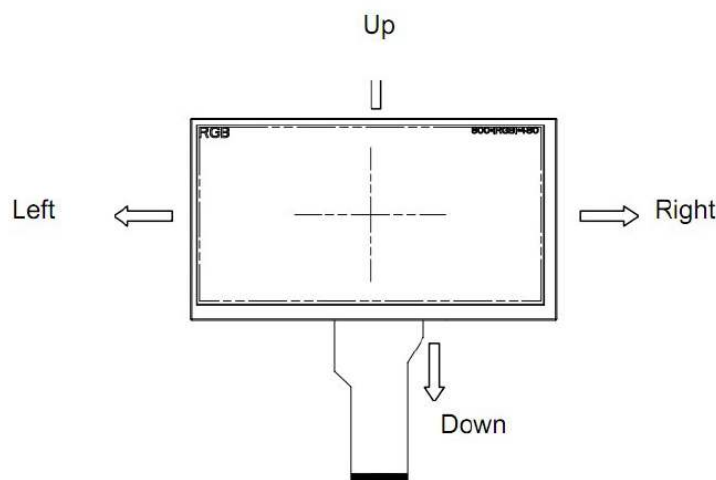

**Note 6.** Global reset pin. Active low to enter reset state, suggest to connect with an RC reset circuit for stability. Normally pull high.

**Note 7.** Dithering function enable control, normally pull high.

When DITHUB="1", Disable internal dithering function.

When DITHUB="0", Enable internal dithering function.



## 13. TIMING CHARACTERISTICS

### 13.1 Horizontal input timing

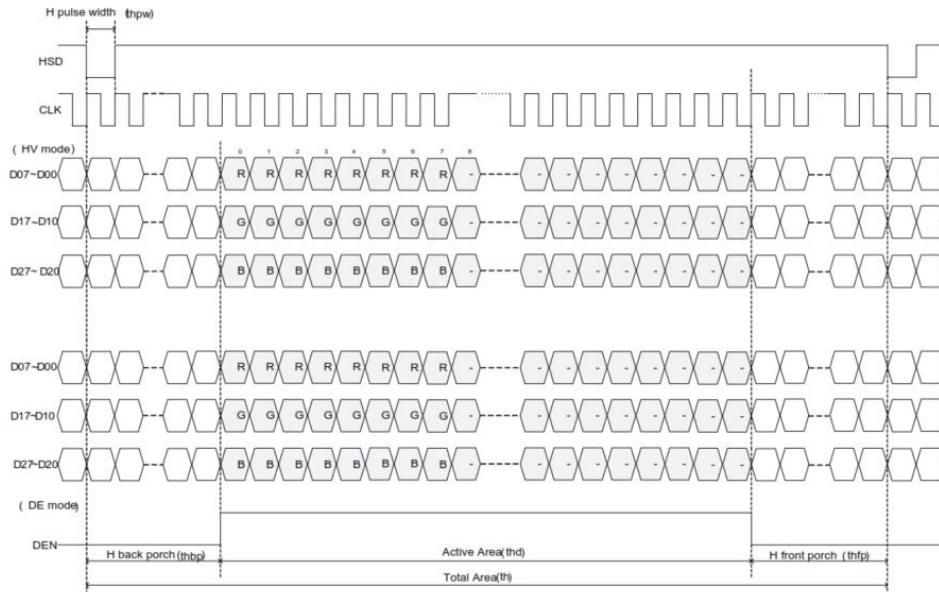

### 13.2 Vertical input timing

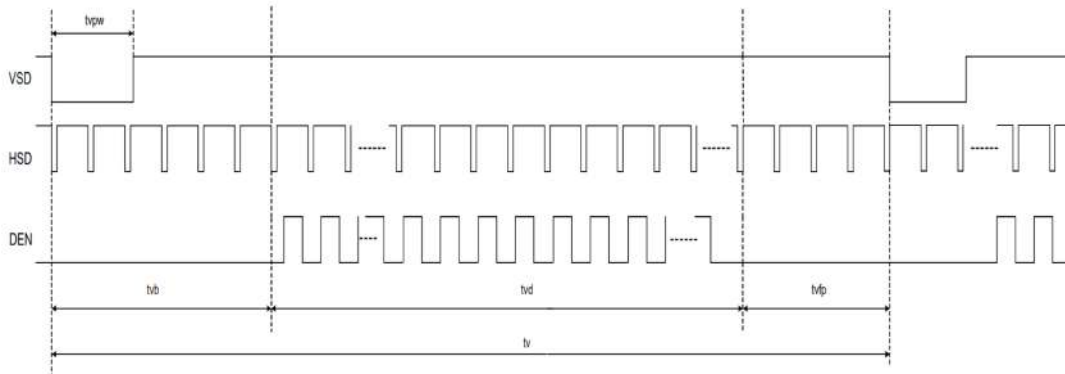



### 13.3 Parallel RGB timing characteristic

**Note:** DE/SYNC mode select. Normally pull high. H:DE Mode. L:HS/VS mode. When select DE mode, MODE="1", VS and HS must pull high.

#### 13.3.1 DE MODE

PARAMETER	SYMBOL	VALUE			UNIT
		MIN.	TYP.	MAX.	
DCLK frequency (Frame rate 60Hz)	fclk	40.8	51.2	67.2	MHz
Horizontal display area	thd	1024			DCLK
HSYNC period time	th	1114	1344	1400	
HSYNC blanking	thb+thfp	90	320	376	
Vertical display area	tvd	600			H
VSYNC period time	tv	610	635	800	
VSYNC blanking	tvb+tvfp	10	85	200	

#### 13.3.2 HV MODE – Horizontal input timing

PARAMETER	SYMBOL	VALUE			UNIT
		MIN.	TYP.	MAX.	
Horizontal display area	thd	1024			DCLK
DCLK frequency (frame rate 60Hz)	fclk	44.9	51.2	63	MHz
1 Horizontal Line	th	1200	1344	1400	DCLK
HSYNC pulse width	thpw	1	-	140	
HSYNC back porch	thbp	160	160	160	
HSYNC front porch	thfp	16	160	216	

#### 13.3.3 HV MODE – Vertical input timing

PARAMETER	SYMBOL	VALUE			UNIT
		MIN.	TYP.	MAX.	
Vertical display area	tvd	600			H
VSYNC period time	tv	624	635	750	
VSYNC pulse width	tvpw	1	-	20	
VSYNC back porch	tvb	23	23	23	
VSYNC front porch	tvfp	1	12	127	

### 13.3.4 Power On/Off sequence

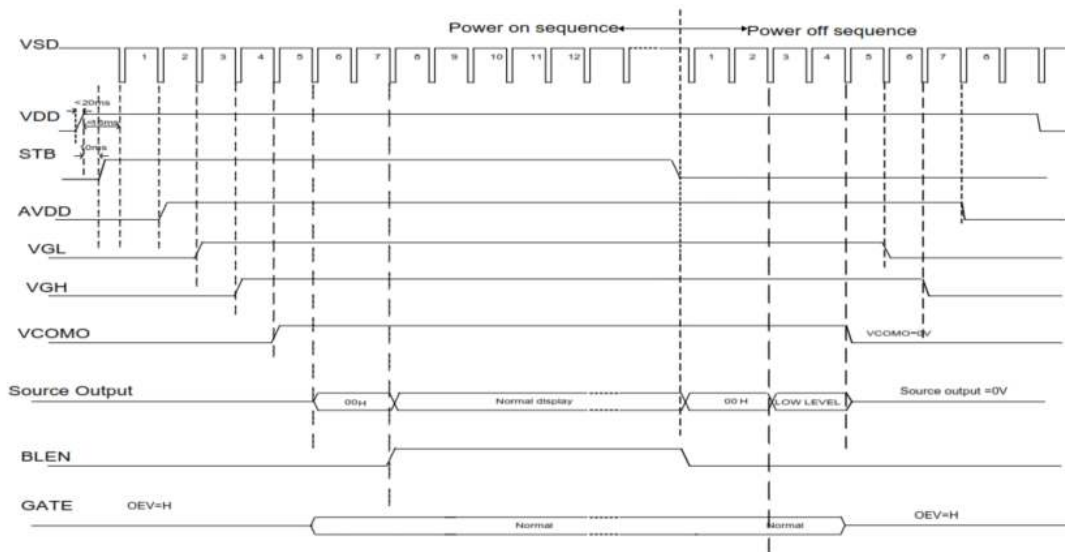

## 14. INSPECTION

Standard acceptance/rejection criteria for TFT module

### 14.1 Inspection condition

Ambient conditions:

- Temperature:  $25 \pm 2^\circ\text{C}$
- Humidity:  $(60 \pm 10) \%RH$
- Illumination: Single fluorescent lamp non-directive (300 to 700 lux)

Viewing distance:  $35 \pm 5\text{cm}$  between inspector bare eye and LCD.

Viewing Angle: U/D:  $45^\circ/45^\circ$ , L/R:  $45^\circ/45^\circ$

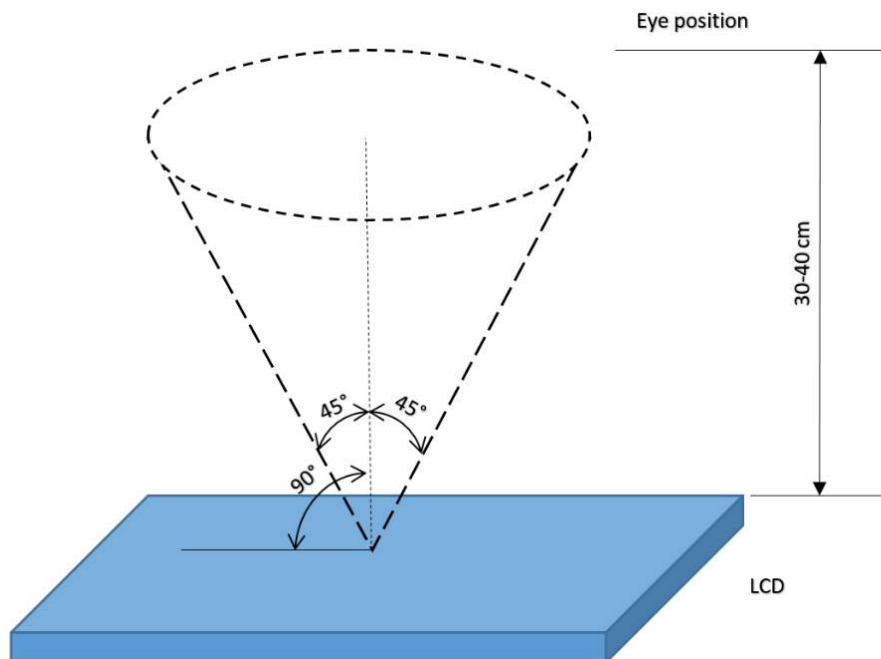



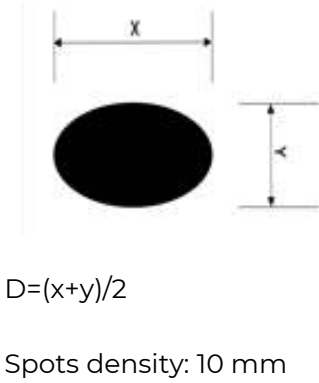
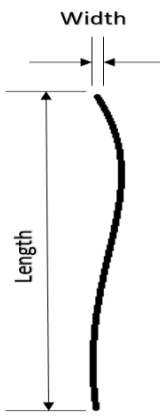

### 14.2 Inspection standard

ITEM		CRITERION		
Black spots, white spots, light leakage, Foreign Particle (round Type)	 <p><math>D=(x+y)/2</math> Spots density: 10 mm</p>	Size =7"		
		Average Diameter	Qualified Qty	
		$D \leq 0.2 \text{ mm}$	Ignored	
		$0.2 \text{ mm} < D \leq 0.3 \text{ mm}$	N≤3	
		$0.5\text{mm} < D$	Not allowed	
LCD black spots, white spots, light leakage (line Type)	 <p>Spots density: 10 mm</p>	Size = 7"		
		Length	Width	Qualified Qty
		-	$W \leq 0.05$	Ignored
		$L \leq 5.0$	$0.05 < W \leq 0.1$	N≤3
		$5.0 < L$	$0.1 < W$	Not allowed
Bright/Dark Dots	Size = 7			
	Item	Qualified Qty		
	Bright dots	N ≤ 2		
	Dark dots	N ≤ 3		
	Total Bright and Dark Dots	N ≤ 4		
Clear spots	Size ≥ 5"			
	Average Diameter	Qualified Qty		
	$D < 0.2 \text{ mm}$	Ignored		
	$0.2 \text{ mm} < D < 0.3 \text{ mm}$	4		
	$0.3 \text{ mm} < D < 0.5 \text{ mm}$	2		
	$0.5 \text{ mm} < D$	0		
	Spots density: 10 mm			
Polarizer bubbles	Size ≥ 5"			
	Average Diameter	Qualified Qty		
	$D < 0.2 \text{ mm}$	Ignored		
	$0.2 \text{ mm} < D < 0.5 \text{ mm}$	2		
	$0.5 \text{ mm} < D$	1		



## 15. RELIABILITY TEST

NO.	TEST ITEM	TEST CONDITION	NOTE
1	High Temperature Storage	80°C/120 hours	Note 1
2	Low Temperature Storage	-30°C/120 hours	
3	High Temperature Operating	70 °C /120 hours	
4	Low Temperature Operating	-20°C/120 hours	
5	High Temperature and High Humidity	Humidity 40°C, 90%RH, 120Hrs	
6	Thermal Cycling Test (No operation)	-20°C for 30min, 70°C for 30 min. 100 cycles. Then test at room temperature after 1 hour	Note 2
7	Vibration Test	Frequency: 10 ÷ 55 Hz. Stroke: 1.5 mm. Sweep: 10Hz ÷ 55Hz ÷ 10 Hz. 2 hours for each direction of X, Y, Z (Total 6 hours)	
8	Package Drop Test	Height: 60 cm 1 corner, 3 edges, 6 surfaces	

**Note 1.** Sample quantity for each test item is 5 ÷ 10 pcs.

**Note 2.** Before cosmetic and function test, the product must have enough recovery time, at least 2 hours at room temperature.



## 16.LEGAL INFORMATION

Riverdi grants the guarantee for the proper operation of the goods for a period of 12 months from the date of possession of the goods. If in a consequence of this guaranteed execution the customer has received the defects-free item as replacement for the defective item, the effectiveness period of this guarantee shall start anew from the moment the customer receives the defects-free item.

Information about device is the property of Riverdi and may be the subject of patents pending or granted. It is not allowed to copy or disclosed this document without prior written permission.

Riverdi endeavors to ensure that all contained information in this document is correct but does not accept liability for any error or omission. Riverdi products are in developing process and published information may be not up to date. Riverdi reserves the right to update and makes changes to Specifications or written material without prior notice at any time. It is important to check the current position with Riverdi.

Images and graphics used in this document are only for illustrative the purpose. All images and graphics are possible to be displayed on the range products of Riverdi, however the quality may vary. Riverdi is no liable to the buyer or to any third party for any indirect, incidental, special, consequential, punitive or exemplary damages (including without limitation lost profits, lost savings, or loss of business opportunity) relating to any product, service provided or to be provided by Riverdi, or the use or inability to use the same, even if Riverdi has been advised of the possibility of such damages.

Riverdi products are not fault tolerant nor designed, manufactured or intended for use or resale as on line control equipment in hazardous environments requiring fail-safe performance, such as in the operation of nuclear facilities, aircraft navigation or communication systems, air traffic control, direct life support machines or weapons systems in which the failure of the product could lead directly to death, personal injury or severe physical or environmental damage ('High-Risk Activities'). Riverdi and its suppliers specifically disclaim any expressed or implied warranty of fitness for High-Risk Activities. Using Riverdi products and devices in 'High-Risk Activities' and in any other application is entirely at the buyer's risk, and the buyer agrees to defend, indemnify and hold harmless Riverdi from all damages, claims or expenses resulting from such use. No licenses are conveyed, implicitly or otherwise, under any Riverdi intellectual property rights.

Hi, I am here to help you!  
If you have any additional  
questions, please contact  
our support via email:  
[contact@riverdi.com](mailto:contact@riverdi.com)

