



TSDMRX-19V20W-EVM
Wireless Charging Receiver

WIRELESS CHARGING

LinkCharge™ 20 Series

User Guide

TSDMRX-19V20W-EVM

Introduction

The Semtech TSDMRX-19V20W-EVM is an evaluation platform for test and experimentation of a wireless charging receiver based on a suite of high efficiency Semtech ICs: the TS81000 Receiver Controller for Wireless Power Systems, TS94033 current sense amplifier IC, and the TS30042 Current-Mode Synchronous Buck DC/DC Converter. This evaluation module provides a complete system solution for inductive standard of wireless power transfer, making this receiver an ideal platform compatible with the majority of wireless power systems in use today.

Please visit www.semtech.com to download the latest EVM software for your evaluation board.

Objectives

The objective of this User Guide is to provide a fast, easy and thorough method to experiment with and evaluate the Semtech solutions for wireless charging systems. Sufficient information is provided to support the engineer in all aspects of adding wireless charging support to their products. Semtech offers a range of solutions to meet the needs of a wide range of system developers. Developers are provided with all the information on how this EVM was built as a starting point for their own designs using the TS81000 and other Semtech components.

Table of Contents

<i>Wireless Charging Concepts</i>	2
<i>Product Description</i>	3
<i>Standard Use</i>	4
<i>Documentation</i>	7
A. Block Diagram	7
B. Schematic	8
C. Bill Of Materials "BOM"	12
D. Board Layout	13
E. Board Layers.....	14
<i>FAQs</i>	15
<i>Next Steps</i>	16

Wireless Charging Concepts

Wireless power transfer is, essentially, a transformer. Power is provided to a primary coil which produces an electromagnetic (EM) field. In this field, a secondary coil is placed. The EM field induces a current into the secondary coil, providing power to whatever it is connected to.

However, unlike a conventional power transformer that operates at line frequencies and requires an iron core for efficiency, wireless power systems are designed to operate in the 100 kHz range, and thus can perform efficiently with an air core. As such, the primary and secondary windings, if closely spaced, can be in separate devices, the primary being part of a transmitter and the secondary within a receiver. This implementation can also be described as a radio broadcast process, and as such, these transformer coils can also be seen as antennas with equal validity, and the two terms will be used interchangeably in this text.

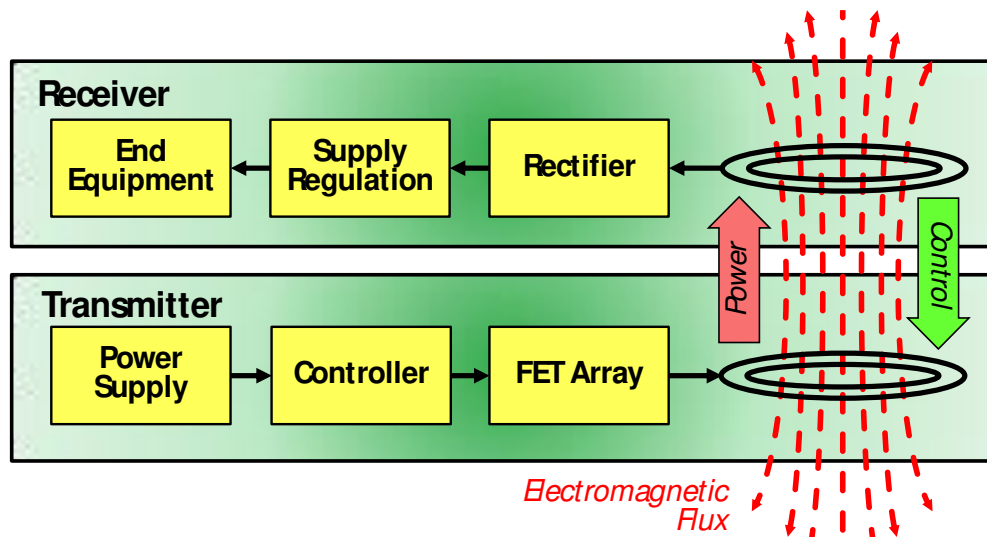

Wireless power systems differ in another major aspect from conventional transformers, in that they are intelligently managed. A transmitter will only provide power when a receiver is present, and only produce the amount of power requested by the receiver. In addition, the system is capable of recognizing when the electromagnetic field has been interrupted by an unintended element, a 'foreign object', and will shut down the transfer to prevent any significant amount of power being absorbed by anything but a proper receiver. The intelligent management of the wireless power transmission process is achieved through the programming of the TS81000. When introduced to a compliant transmitter, the TSDMRX-19V20W-EVM receiver informs the transmitter of its power requirements, and transmission begins. The receiver then verifies the right amount of power is being sent, and that none is being lost to foreign objects. The receiver continually provides ongoing requests for power to maintain the transaction. If these requests cease, the transaction terminates. Via this protocol, even complex charging patterns can be supported, as the transmitter can provide varying amounts of power at different times, as requested by the TSDMRX-19V20W-EVM. Should the TSDMRX-19V20W-EVM require no further power, such as when a battery charge is completed, it can request no further power be sent, and the transmitter will reduce its output accordingly.

Wireless power systems have been broken into three basic power categories. "Wearable" devices, such as headsets, wrist-band devices, medical sensors, and so forth - all operate in the low power range, up to 5 watts. Medium power devices, in the 5- to 15-watt range, include most handheld devices, such as cell phones, tablets, and medical electronics. High power wireless systems are intended to support devices such as power tools, radio controlled ("RC") devices such as drones, and other equipment requiring 15 to 100 watts of power.

Product Description

The TSDMRX-19V20W-EVM Evaluation Module is a ready-to-use demonstration platform allowing testing of up to 20 watts of wireless power transmission using a proprietary communication protocol as well as backward compatibility with the industry inductive standard to charge devices at 15W or below. For 20 watts operation, the transmitter must be paired with Semtech's Transmitter **TSDMTX-19V2-EVM (firmware version should be 004F or newer)**, which can allow a variety of experiments to easily be performed in order to learn more about the behavior of the system.

To develop your own board, or integrate this functionality into an existing system, the EVM can be used as a starting point for the design, as it demonstrates a working model from which to proceed. Toward this end, all documentation for the EVM is provided to make the process as efficient as possible.

The key technology components of the EVM are a trio of Semtech integrated circuits, the TS81000, TS94033, and TS30042. The TS81000 provides the Qi compliant communications and control for wireless receivers of up to 40 watts. All the intelligent management of the process is handled by the TS81000. Up to 20 watts of power acquired from the receiver antenna is rectified to 21.5-28.0 VDC. The TS94033 senses the DC current. The TS30042 is the final part of the process, where the output of the rectification is converted to 19VDC for output to the system load. This EVM presents a working example of how these three components can be used together to form a complete wireless power receiver solution with high efficiency, low part count and minimized space requirements.

As seen in the photo below, at the left is antenna leads and the right port can be used to provide output power to a device. In a 31x16mm portion of the board is the receiver, indicating the size of the actual receiver system. Right down below is the connector for programming. Some will be employed in the following text; all are documented in the schematic diagram below.

In the following section, an introduction will be provided to the evaluator for how to use the EVM for wireless power reception as well as how the TSDMTX-19V2-EVM can be used in conjunction with.

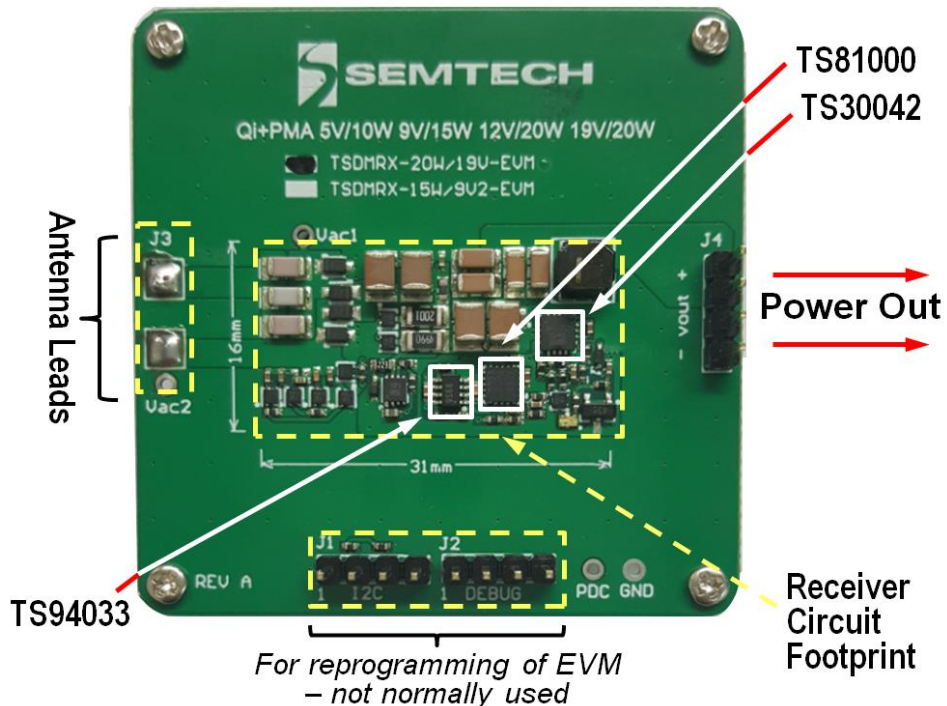

Standard Use

The TSDMRX-19V20W-EVM is very easy to use. Start by applying power to the TSDMTX-19V2-EVM transmitter. A few times each second, the transmitter emits a ‘ping’ of energy in search of a compliant receiver in range - in this document, the TSDMRX-19V20W-EVM.

Place the TSDMRX-19V20W-EVM over the target area of the transmitter EVM. The TSDMRX-19V20W-EVM is initially powered by the ping sufficiently to be able to announce its presence to the transmitter, and a transaction begins. The transmitter next provides a small amount of power to the newly discovered receiver, so the TSDMRX-19V20W-EVM can tell the transmitter what its power requirements are.

At the completion of this handshake, the transmitter begins providing the requested power, indicated by a green LED on the receiver EVM. During power transfer, the TSDMRX-19V20W-EVM continuously communicates with the transmitter, actively directing the process. In this way, it is assured that power is only sent when and how it is required by the receiver. If required by the load, the TSDMRX-19V20W-EVM can actively increase or decrease its power request, and the transmitter will act accordingly. As such, equipment with complex charging requirements can be precisely supported by the TSDMRX-19V20W-EVM and only the desired amount of power is provided. If at any time an error is detected, transmission is halted. To restart, the TSDMRX-19V20W-EVM must be removed from the range of the transmitter and returned to the target zone to start a new transaction.

The receiver EVM can deliver up to 20 watts of power at 19 volts to any load the user would like to experiment with. For general experimentation, the optimal load to select would be a Programmable DC Electronic Load. A ‘load box’ can easily be set to draw a selected current or power at the turn of a knob, making them very flexible and easy to use in observing power supply operation in general. If a load box is not available, a power resistor decade box is nearly as convenient, as it can easily be set to any desired resistance to simulate a range of load conditions. In either case, be sure the test load is rated for at least the amount of power being tested.

Run wires from the VOUT+ and - pins of the receiver EVM to the selected test load, as per the illustration below. Once the load is added, the receiver EVM can be used to perform a variety of tests.

Note: In-band communication between the RX and the TX is done using load modulation. At light loads a minimum load is generated using R15, but that may not be enough to maintain optimal communication. **An external load of 100-200mA is necessary to prevent communication dropouts.**



Connect a DC voltmeter across the VOUT+ and - pins to monitor the voltage being output to the load, and a DC ammeter in series with the VOUT+ line. Set levels to allow for up to 20 volts and 1.5 amps to be observed.

With no load selected, place the receiver on the center of the transmitter target circle. Once transmission begins, you should observe approximately 19 volts and 0 amperes on the meters.

Apply a variety of loads to observe performance at 20 watt levels. Voltage should remain nearly constant, and current should follow the $P=V*I$ relationship. Experiment with the maximum power that can be drawn before the receiver detects an overload and cuts off power. You should be able to observe on a minor overload, the receiver will attempt to restore power by retesting the load intermittently. In the case of a major overload, the transmitter may register an error, as indicated by a red LED on the transmitter, which will halt further activity until the receiver is removed from the target area for several seconds before being returned to start a new transaction.

Observe Coil Signals

The following information is not required in order to use the EVM, as what can be observed below is entirely managed by the Semtech TS81000 Wireless Controller. However, it allows the observer an opportunity to see how the receiver and transmitter actively manage the wireless power process.

If you wish to observe the intrinsic wireless process, place an oscilloscope probe on the antenna leads, with the probe ground run to the board ground. Be sure the scope can handle signals up to 200 volts. While the EVM power output is only 19 volts, the antenna is part of a resonant circuit where considerably higher voltages are developed.

Place the receiver on the transmitter target. With the scope set to 0.5 to 1 uSec and 10 to 20 volts per division, you should observe a signal that is a composite of the sinusoidal power signal with a digital 'notch' in the sinewave which is produced by the communication between the receiver and transmitter. Note as you vary the load and the location of the receiver on the target that the amplitude and frequency of the coil signal changes. The greater the load, the more signal is sent to transfer the power required by the load. Similarly, the less well coupled the receiver antenna is to the transmitter coil, the more power must be sent to compensate for the inefficient misalignment.

Measure Efficiency

By measuring the power from the receiver's VOUT+ and - pins in comparison to the power entering the transmitter EVM, you can determine the efficiency of the power transfer through the system. For the EVMs used here (TSDMRX-19V20W-EVM on TSDMTX-19V2-EVM), the diagram below demonstrates that DC-DC efficiency is a function of output current, and runs about 85% at higher power levels, assuring good efficiency and minimal heat dissipation concerns. In certain applications a heatsink or heatspreader may need to be attached to the PCB to keep the temperature within desired limits.

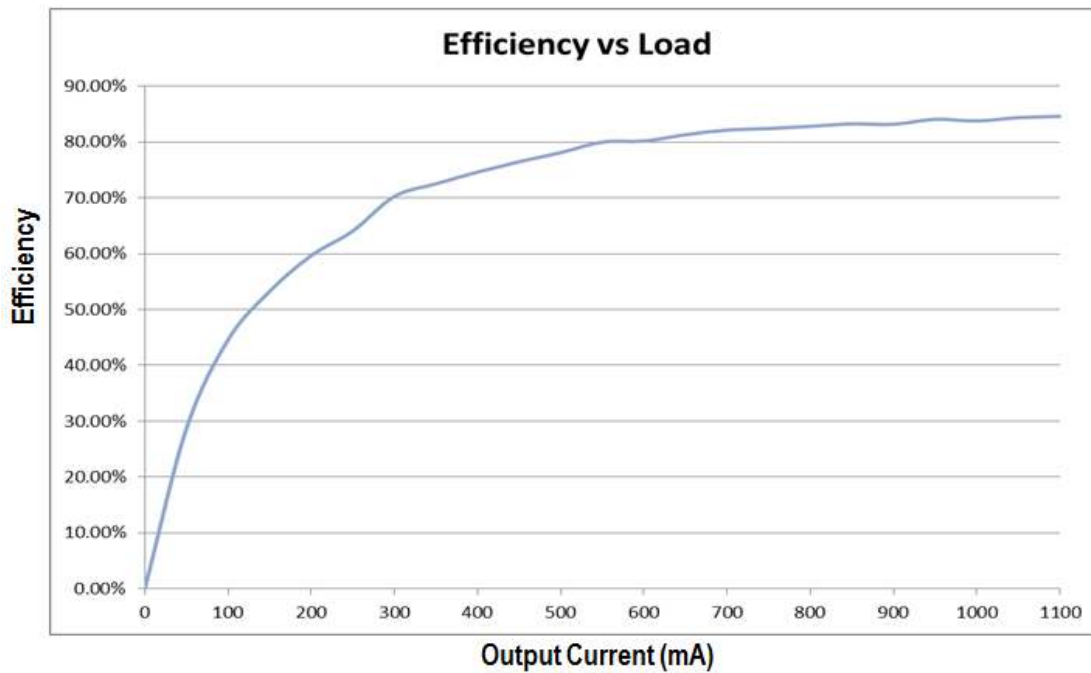

Documentation

The following sections document the hardware design of the TSDMRX-19V20W-EVM. This information can be used to better understand the functionality of the design, as well as assist in creating your own hardware solution based on this design.

A. Block Diagram

The TSDMRX-19V20W-EVM may be divided into a number of sub-blocks as show in the diagram:

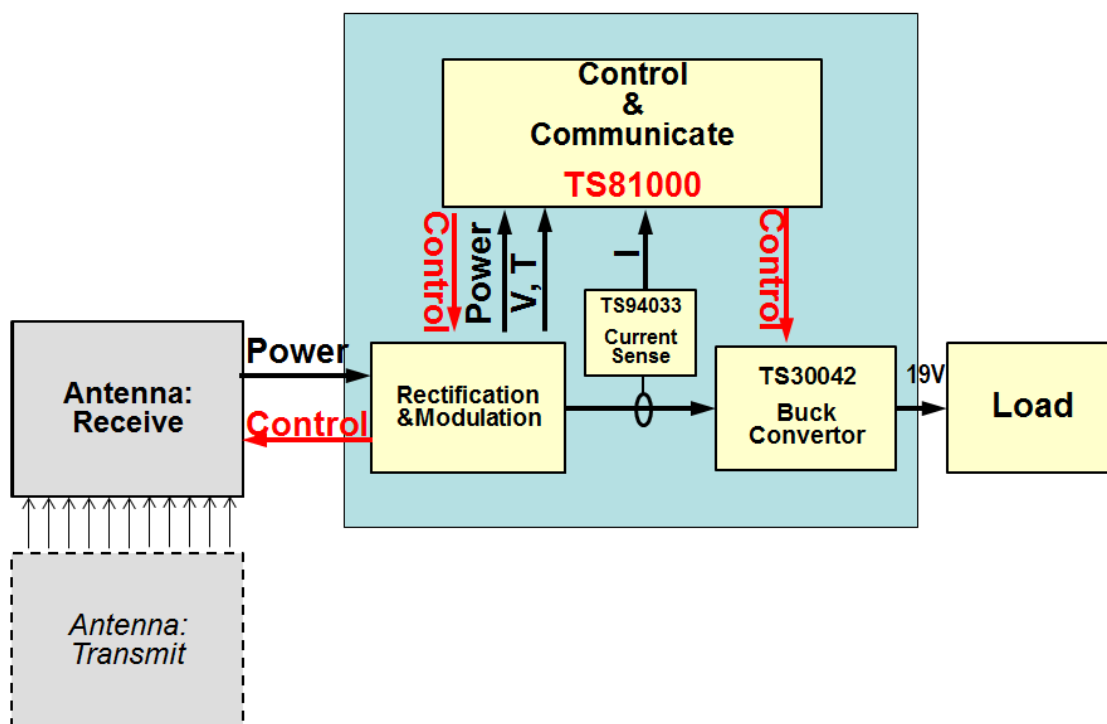

Antenna: Transmit – power source driving the receiver EVM (in this document: part of the TSDMTX-19V2-EVM).

Antenna: Receive – coil of wire placed in proximity to the transmit antenna to power the EVM receiver system. Also includes zero-crossing detection and over-voltage protection circuitry.

Rectification&Modulation – full wave Rectifier Bridge.

Current Sense – low power low offset current sense aplifier IC based on the TS94033.

Controller – based on the TS81000 High Efficiency Receiver Controller for Wireless Power Systems. The TS81000 collects voltage, current, and temperature feedback signals from the receiver system, controls the actions.

DC/DC Converter – based on the TS30042 Switching frequencies 1MHz, 2A Current-Mode Synchronous Buck DC/DC Converter, which converts 19VDC at up to 1.1 amperes for use by the user-selected user of the received power.

B. Schematic

Below are two copies of the schematic. The first, annotation has been added to indicate which part of the block diagram each component is a member of. The second will allow better use in print-out form, as the landscape orientation allows a larger image to be provided.

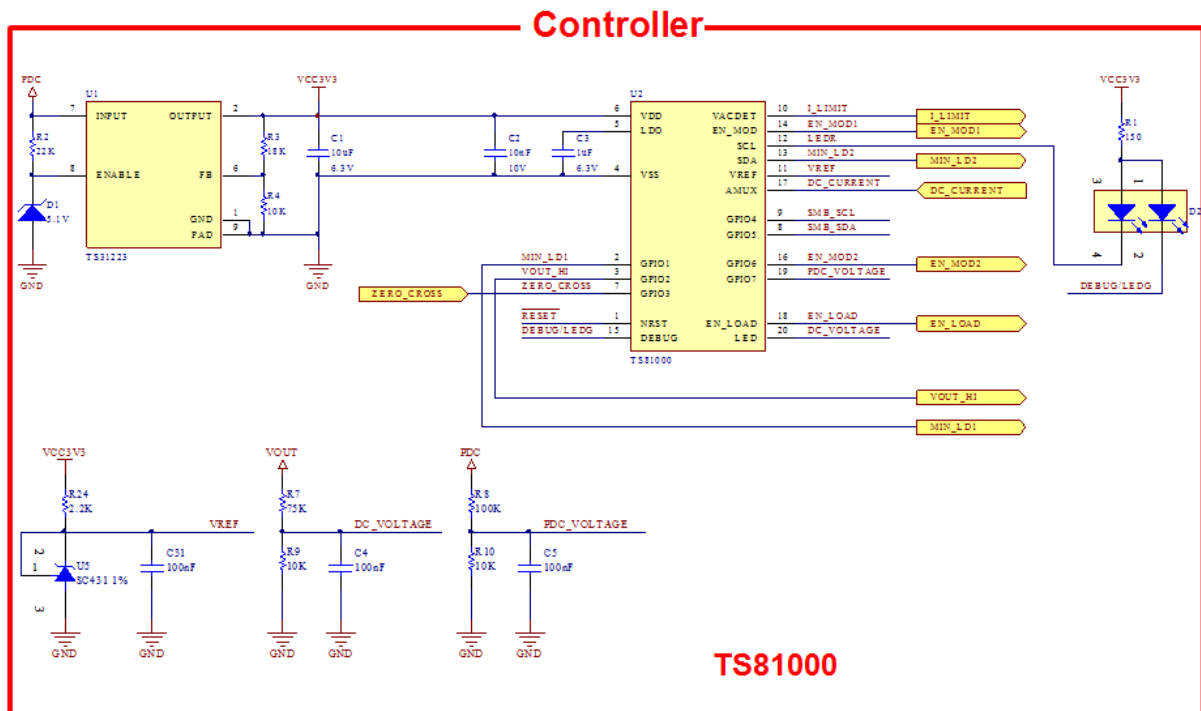
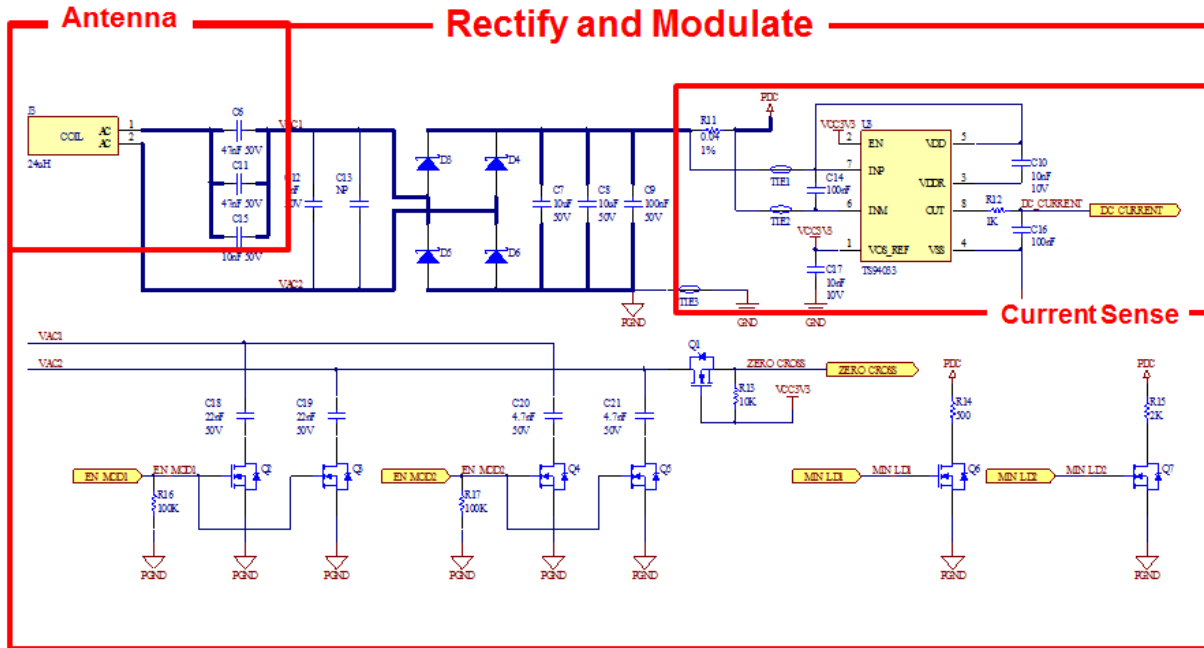

Buck convertor

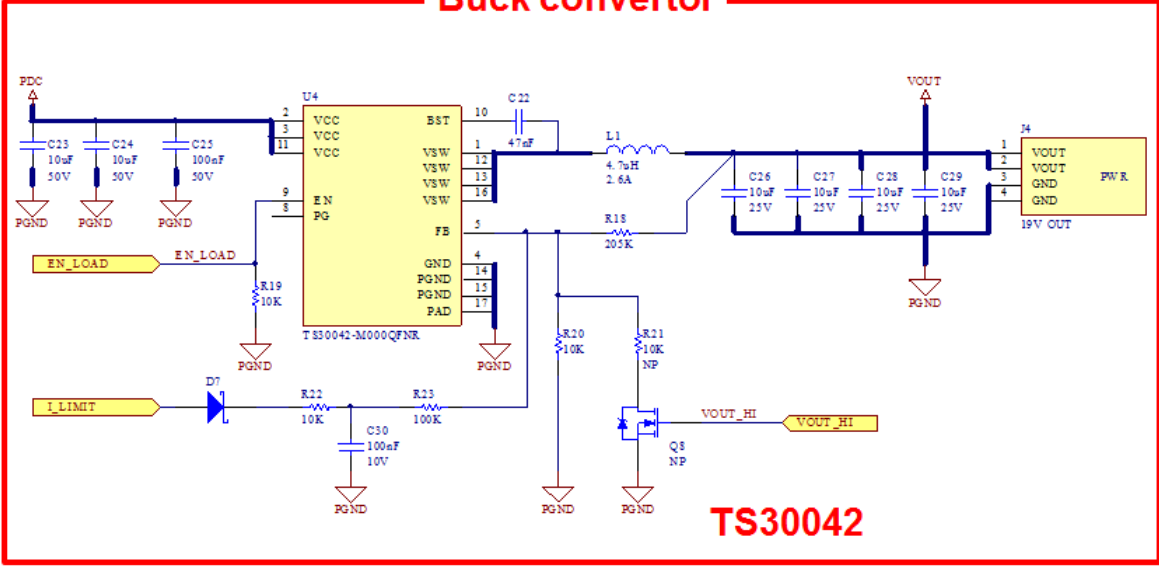

Test & Debug

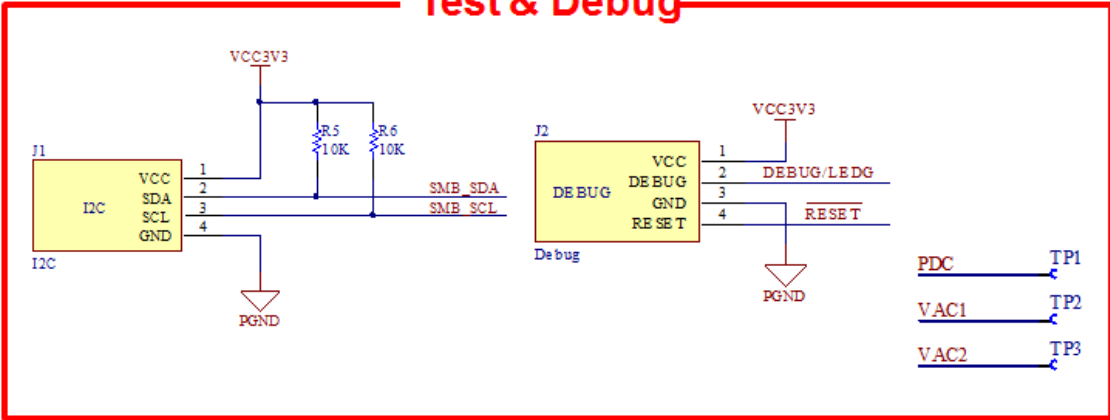

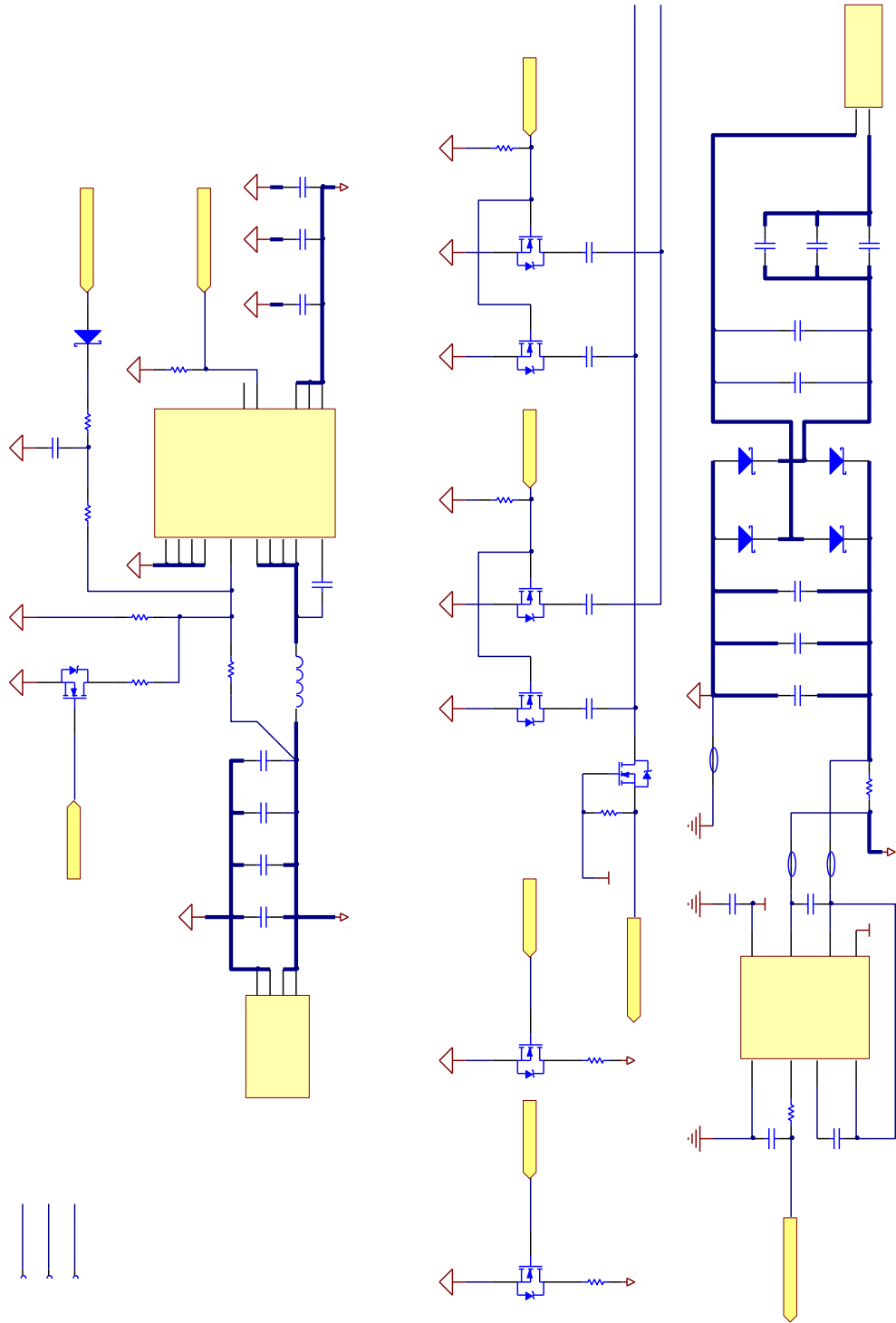

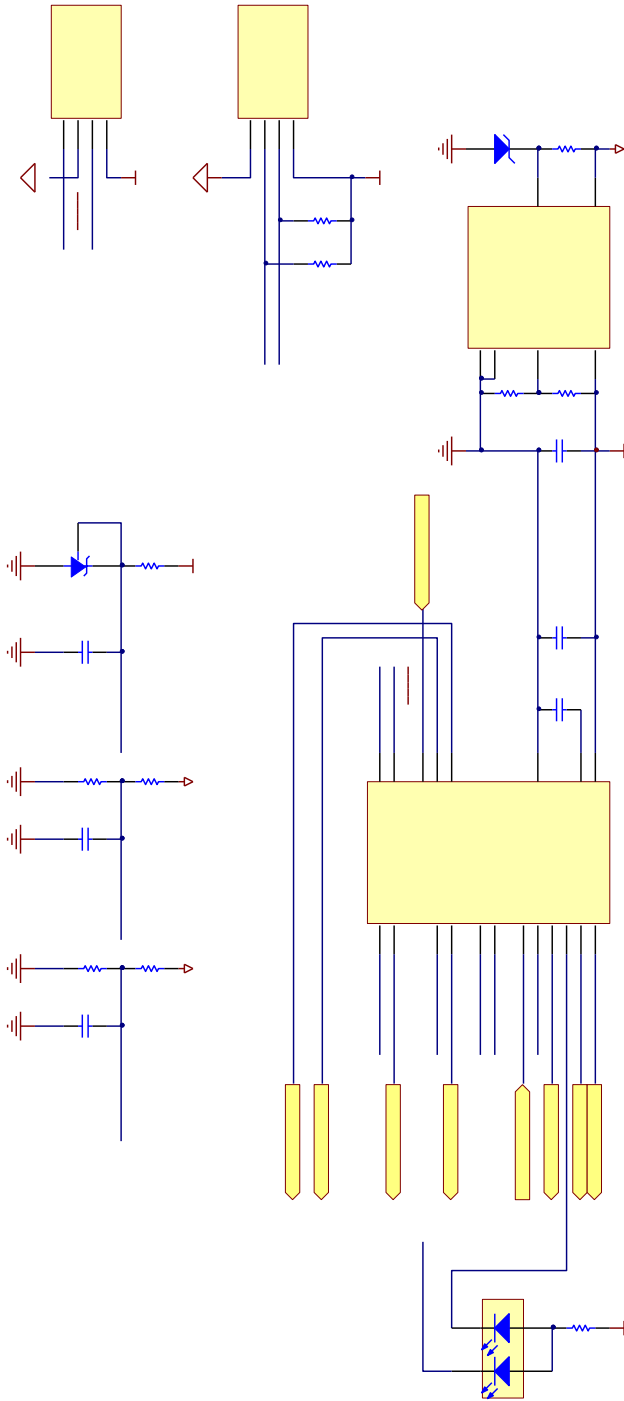

C. Bill Of Materials “BOM”

Below is a listing of the parts used in the TSDMRX-19V20W-EVM. An excel spreadsheet file with this information is available on the Semtech website as an added convenience.

Designator	Description	Value	Footprint	Manufacturer	ManufacturerCode	Quantity
1 C1	Capacitor	Cap 10uF 6.3V	CAPC0402L			1
2 C2, C10, C17	Capacitor	Cap 10nF 10V	CAPC0402L			3
3 C3	Capacitor	Cap 1uF 6.3V	CAPC0402L			1
4 C4, C5, C14, C16, C31	Capacitor	Cap 100nF 10V	CAPC0402L			5
5 C6, C11	Capacitor	Cap C0G 47nF 50V	CAPC1206-0805N	TDK	CGA5H2C0G1H473J	2
6 C7, C8, C23, C24	Capacitor	Cap X7R 10uF 50V	CAPC1210N	Taiyo Yuden	UMK325AB7106MM-T	4
7 C9	Capacitor	Cap 100nF 50V	CAPC0402L			1
8 C12	Capacitor	Cap 1nF 50V	CAPC0402L			1
9 C13	Capacitor	Cap NP	CAPC0402L			1
10 C15	Capacitor	Cap C0G 10nF 50V	CAPC1206-0805N	TDK		1
11 C18, C19	Capacitor	Cap 22nF 50V	CAPC0402L			2
12 C20, C21	Capacitor	Cap 4.7nF 50V	CAPC0402L			2
13 C22	Capacitor	Cap 47nF 50V	CAPC0402L			1
14 C25	Capacitor	Cap 100nF 50V	CAPC0402L	Kemet	C0603C104K5RAC7867	1
15 C26, C27, C28, C29	Capacitor	Cap X7R 10uF 25V	CAPC1206N	Taiyo Yuden	TMK316B7106KL-TD	4
16 C30	Capacitor	Cap 100nF 10V	CAPC0402L	Kemet	C0603C104K5RAC7867	1
17 D1	Zener Diode	5.1V	SOD523-L	ON Semiconductor	MM525V1T1G	1
18 D2	LED Dual Color	APHB1608ZGSURKC	LED_APHB1608	Kingbright		1
19 D3, D4, D5, D6	Schottky Diode	DB2141200L	DIODE-SMini2	Panasonic	DB2141200L	4
20 D7	Schottky Diode	BAS40-02V-V-G-08	SOD523-L	Vishay	BAS40-02V-V-G-08	1
21 J3	Coil connector, 2 contacts, solder pads	24uH		Abracon	AWCCA-RX350300-101	1
22 J4	Power connector	19V OUT	CON_Pins_4p			1
23 L1	Inductor	4.7uH 2.6A	IND_NRS5030	Taiyo Yuden	NRS5030T4R7MMGJV	1
24 Q1, Q2, Q3, Q4, Q5, Q6, Q7	N-Channel Power MOSFET	DMN62D0LFD-7	DFN80P120X120-3	Diodes, Inc.	DMN62D0LFD-7	7
25 Q8	N-Channel Power MOSFET	DMN62D0LFD-7 NP	DFN80P120X120-3	Diodes, Inc.	DMN62D0LFD-7	1
26 R1	Resistor	Res 150	RESC0402L			1
27 R2	Resistor	Res 22K	RESC0603L			1
28 R3	Resistor	Res 18K	RESC0402L			1
29 R4, R5, R6, R9, R10, R13, R19, R20, R22	Resistor	Res 10K	RESC0402L			9
30 R7	Resistor	Res 75K	RESC0402L			1
31 R8, R16, R17, R23	Resistor	Res 100K	RESC0402L			4
32 R11	Current Sense Resistor	0.04 1%	RESC0603L	Vishay	WSL0603R0400FEA18	1
33 R12	Resistor	Res 1K	RESC0402L			1
34 R14	Resistor	Res 500	RESC1206N			1
35 R15	Resistor	Res 2K	RESC1206N			1
36 R18	Resistor	Res 205K	RESC0402L			1
37 R21	Resistor	Res NP	RESC0402L			1
38 R24	Resistor	Res 2.2K	RESC0402L			1
39 U1	Linear Regulator	TS31223	DFN50P200X200-8V6-165N	Semtech	TS31223	1
40 U2	Wireless Power Receiver Controller	TS81000	UFQFPN50P300X300-20VL	Semtech	TS81000-2YA0060	1
41 U3	Current Sense Amplifier	TS94033	SC70-8N	Semtech	TS94033SKTRC	1
42 U4	Buck DC/DC Converter	TS30042-M000QFN	QFN50P300X300-16V6-165N	Semtech	TS30042-M000QFN	1
43 U5	Programmable Precision Reference	SC431 1%	SOT23-3N	Semtech	SC431CSK-1TRT	1

D. Board Layout

The diagram below shows the locations of the components used in the TSDMRX-19V20W-EVM PCB. Note especially that the majority of the board area is devoted to pinouts for testability, and that the actual circuit implementation footprint is 16mm x 31mm.

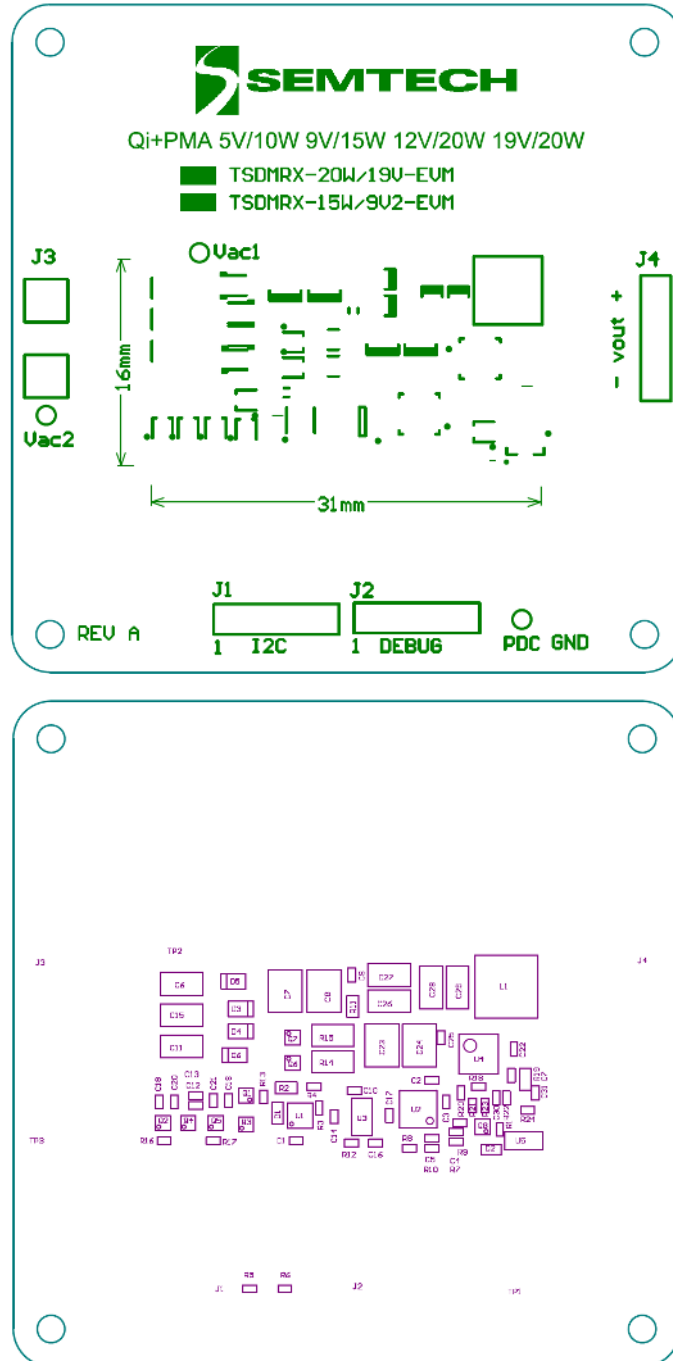

E. Board Layers

The TSDMRX-19V20W-EVM PCB is based on a four layer design as shown below. The ground plane in layer two is recommended to reduce noise and signal crosstalk. The EVM placed all components on the top of the board for easier evaluation of the system. End product versions of this design can be made significantly smaller by distributing components on both sides of the board. The Gerber files for this artwork can be downloaded from the Semtech web page.

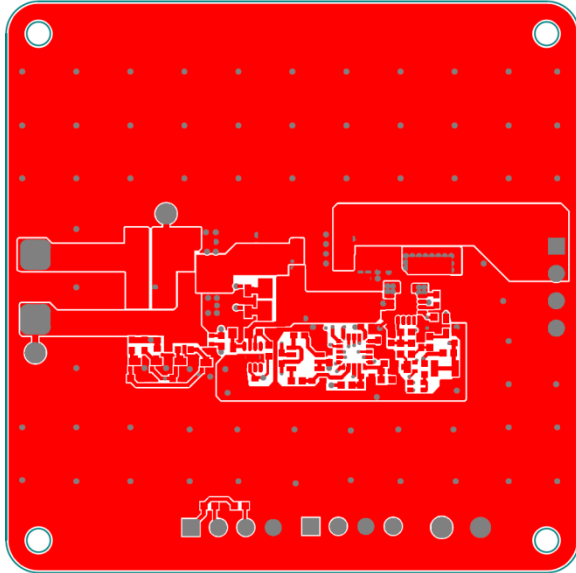

Top Layer

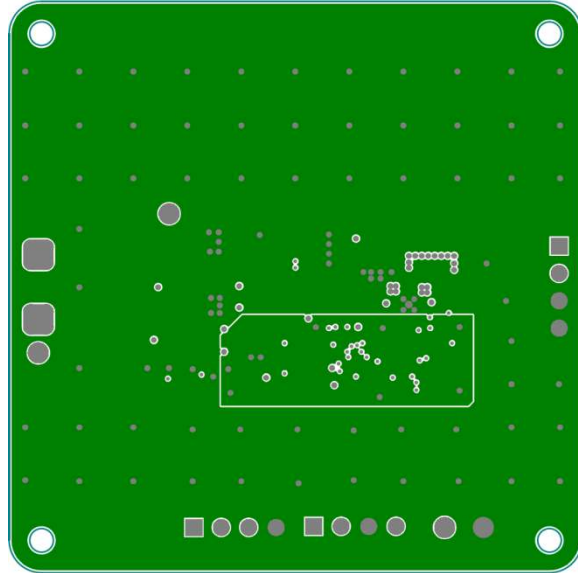

Ground Plane

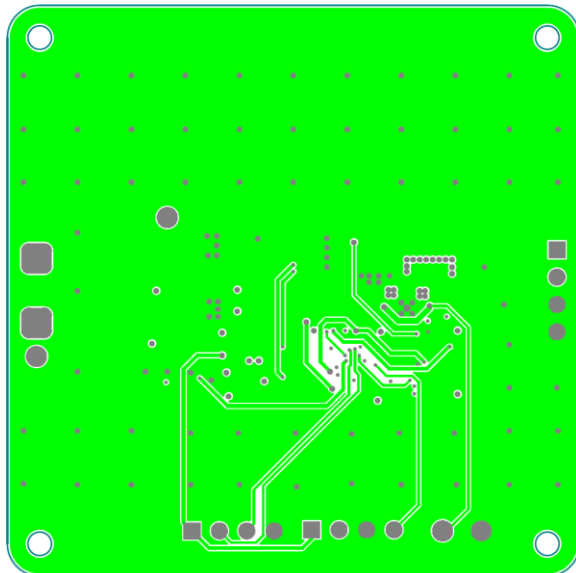

Signal Layer

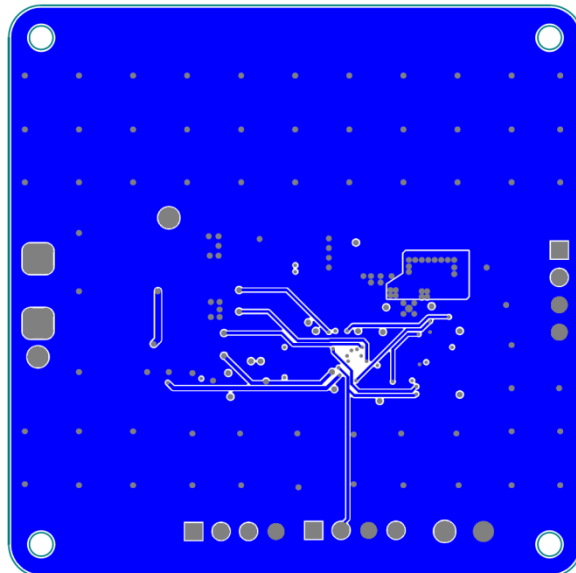

Bottom Layer

FAQs

Q: What output voltage is provided by the TSDMRX-19V20W-EVM system?

A: 19 volts, at up to 20 watts total power.

Q: What mode does the TSDMRX-19V20W-EVM operate in?

A: The receiver operates with Qi signaling on Semtech 19V2 (TSDMTX-19V2-EVM) transmitters.

Q: Where can I find more information on the Qi and PMA standards?

A: There are a number of websites that address this subject. A good starting point for Qi would be: <http://www.wirelesspowerconsortium.com/technology/how-it-works.html>. PMA, which is now joined with A4WP, is now called AirFuel. Information on them can be found at the following website: <http://www.airfuel.org/technologies/inductive>.

Q: Does the EVM part number represent something in particular?

A: Yes. The part number is broken into a prefix, main body, and suffix, separated by dashes. The prefix is comprised of three two letter groupings that each help define the product represented. As such, the part number can be read as follows:

Prefix characters:

1+2 = Company :	TS= Triune/Semtech	
3+4 = Environment :	DM = Dual Mode	WI = Wearable Infrastructure
5+6 = Type :	TX = Transmit	RX = Receive

Mid-section = Device Voltage and/or Wattage

Suffix = Equipment type:

EVM = Evaluation Module
MOD = Production Module

Therefore, the TSDMRX-5V/10W-EVM is a Dual Mode, 5Volt, 10 Watt Receiver Evaluation Module provided by Semtech.

Q: What if my questions weren't answered here?

A: Please visit the Semtech website as described on the next page. An updated FAQ as well as latest firmware for the TSDMRX-19V20W-EVM is maintained there and may contain the answers you're looking for. Your local Semtech FAE can also assist in answering your questions.

Next Steps

For more information on Wireless Power, go to the Semtech webpage at:
<http://semtech.com/wireless-charging>

You may also scan the bar code to the right to go to the above web page:



There you can find the downloadable copies of the schematic, BOM, and board artwork, as well as additional information on how to obtain Semtech wireless power products, from the chip level all the way to complete board modules, as your needs require.



IMPORTANT NOTICE

Information relating to this product and the application or design described herein is believed to be reliable, however such information is provided as a guide only and Semtech assumes no liability for any errors in this document, or for the application or design described herein. Semtech the latest relevant information before placing orders and should verify that such information is current and complete. Semtech reserves the right to make changes to the product or this document at any time without notice. Buyers should obtain warrants performance of its products to the specifications applicable at the time of sale, and all sales are made in accordance with Semtech's standard terms and conditions of sale.

SEMTECH PRODUCTS ARE NOT DESIGNED, INTENDED, AUTHORIZED OR WARRANTED TO BE SUITABLE FOR USE IN LIFE-SUPPORT APPLICATIONS, DEVICES OR SYSTEMS, OR IN NUCLEAR APPLICATIONS IN WHICH THE FAILURE COULD BE REASONABLY EXPECTED TO RESULT IN PERSONAL INJURY, LOSS OF LIFE OR SEVERE PROPERTY OR ENVIRONMENTAL DAMAGE. INCLUSION OF SEMTECH PRODUCTS IN SUCH APPLICATIONS IS UNDERSTOOD TO BE UNDERTAKEN SOLELY AT THE CUSTOMER'S OWN RISK. Should a customer purchase or use Semtech products for any such unauthorized application, the customer shall indemnify and hold Semtech and its officers, employees, subsidiaries, affiliates, and distributors harmless against all claims, costs damages and attorney fees which could arise.

The Semtech name and logo are registered trademarks of the Semtech Corporation. All other trademarks and trade names mentioned may be marks and names of Semtech or their respective companies. Semtech reserves the right to make changes to, or discontinue any products described in this document without further notice. Semtech makes no warranty, representation or guarantee, express or implied, regarding the suitability of its products for any particular purpose. All rights reserved.

© Semtech 2015

Contact Information

Semtech Corporation
200 Flynn Road, Camarillo, CA 93012
Phone: (805) 498-2111, Fax: (805) 498-3804
www.semtech.com