

NB4N441MNGEVB

NB4N441MNGEVB Evaluation Board User's Manual

Device Name: NB4N441MN



ON Semiconductor®

<http://onsemi.com>

EVAL BOARD USER'S MANUAL

Description

The NB4N441MNG is a precision clock PLL based synthesizer which generates select differential LVPECL clock output frequencies from 12.5 MHz to 425 MHz. A Serial Peripheral Interface (SPI) is used to configure the device to produce output frequencies from a single 27 MHz crystal input reference by programming three internal registers, P (pre-scale), M (PLL Feedback Divider), and N (Output Divider) using a three line LVTTTL/LVCMOS Serial Data Interface (SDI) consisting of a SERIAL DATA (SDATA) input, a SERIAL CLOCK (SCLOCK) input, and a SERIAL LOAD (SLOAD).

The NB4N441MNGEVB Evaluation board is designed to provide a flexible and convenient platform to quickly program, evaluate and verify the performance and operation of the NB4N441MNG device under test: With the device removed, this NB4N441MNGEVB Evaluation board is designed accept a 24 LD QFN GCI socket (M&M Specialties, Inc., 1-800-892-8760, www.mmspec.com, Dwg No.50-000-00306) to permit use as an insertion test fixture.

Board Features

- On board 27 MHz crystal source, or input external clock source (SMA)
- On board serial data loader with 16-bit DIP switches, or externally serial program through SMA connectors.
- PLL In Lock LED status indicator.
- 3.3 V split-power supply operation (banana jack and anvil supply connectors for V_{CC}, SMAGND, and DUTGND)
- LVPECL differential output signals via SMA connectors with provision for termination resistors.

Contents

- Description
- Board Features
- Board Layout Map
- Test and Measurement Setup Procedures

Appendix 1: Device Information

Appendix 2: Schematics

Appendix 3: Bill Of Materials, Lamination Stackup

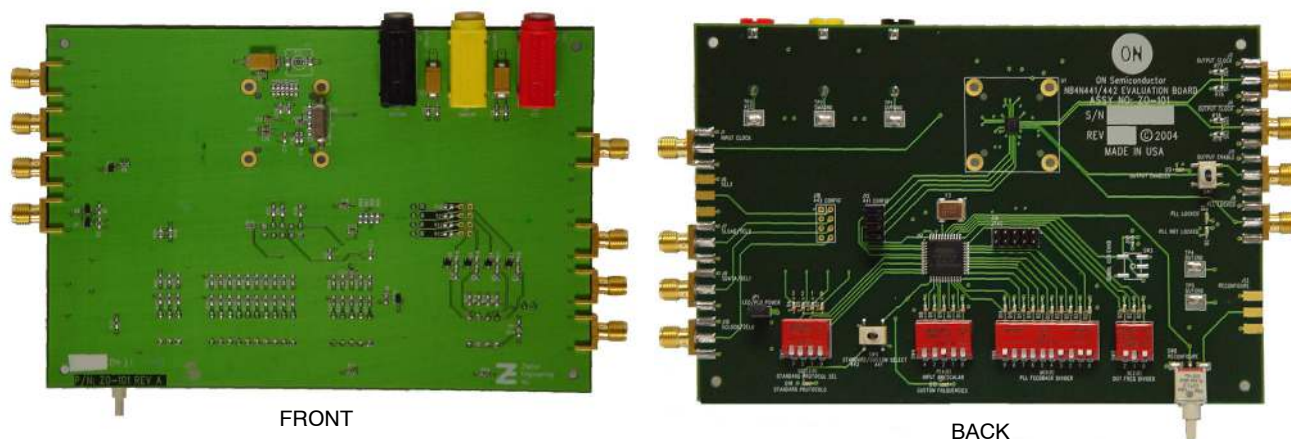
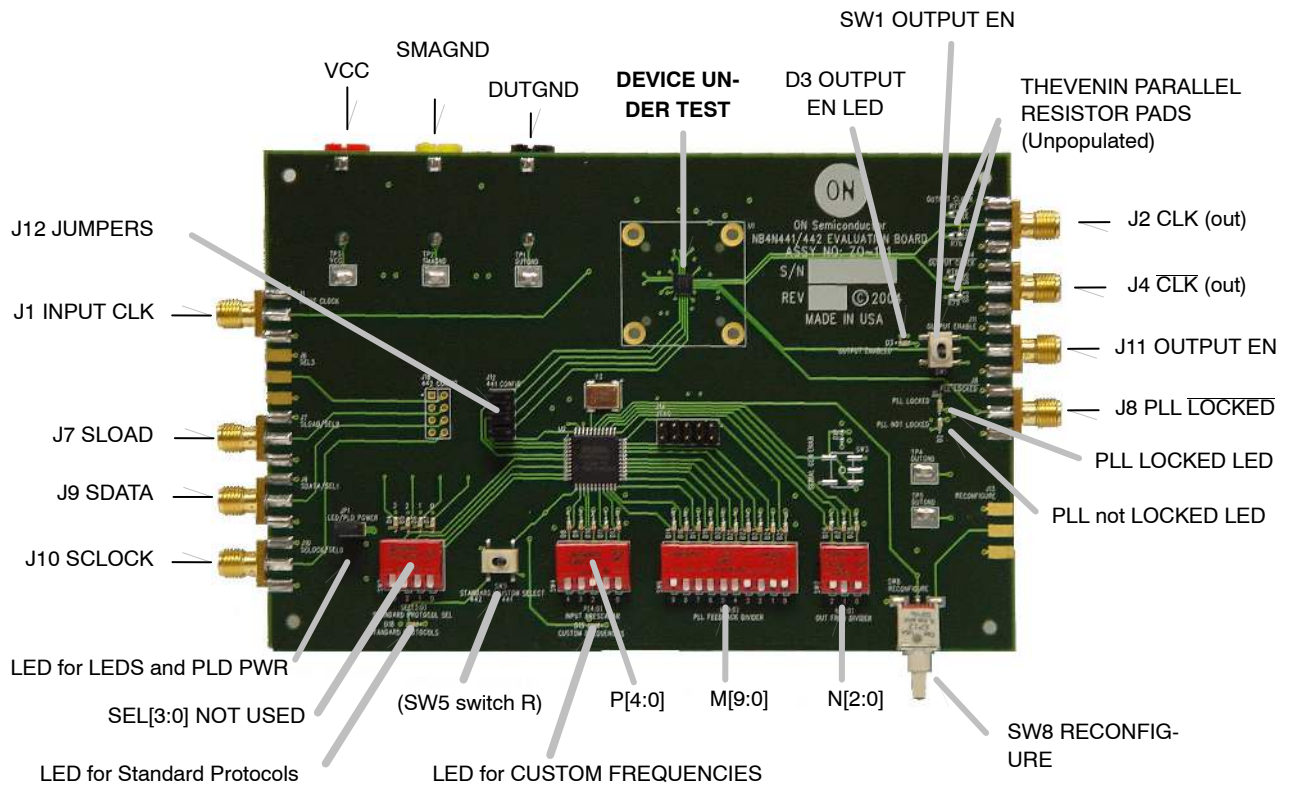

Figure 1. NB4N441MNGEVB Evaluation Board

NB4N441MNGEVB

BOARD LAYOUT MAP



FRONT

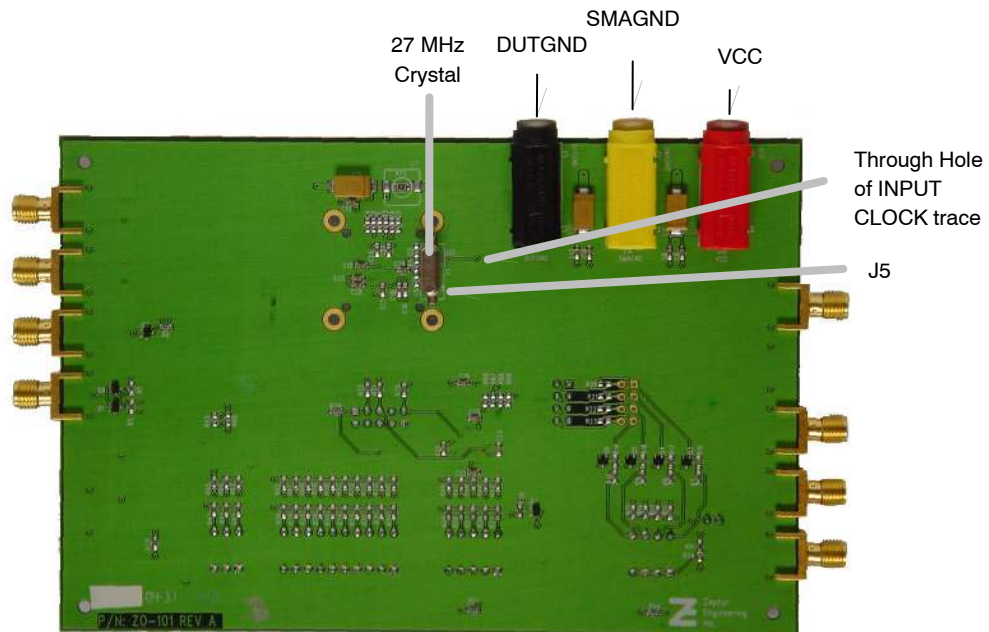

BACK

Figure 2. Board Layout Map

TEST AND MEASUREMENT SETUP AND PROCEDURE

Step 1: Equipment (or equivalent)

1. Agilent Signal Generator #33250A for CLK input
2. Tektronix TDS8000 Oscilloscope or Frequency Counter
3. Agilent #6624A DC Power Supply
4. Digital Voltmeter
5. Matched high-speed cables with SMA connectors

Step 2: Lab Setup Procedure for Split Supplies (into LOW impedance 50 Ω equipment or probes)

1. **Output Enable OFF:** Switch SW1 (UP) or externally LOW through J11 (offset LVCMOS/LVTTL of 2.0 V HIGH and -1.3 V LOW) to disable the output during setup. LED D3 indicator will be off to indicate disabled output.
2. **Supplies:** Connect a “split” power supply to the evaluation board for 3.3 V operation as follows:
 - V_{CC} (RED banana jack or clip anvil) at +2.0 V
 - SMAGND (YELLOW banana jack or clip anvil) at 0 V
 - DUTGND (BLACK banana jack or clip anvil) -1.3 V

3. **Output:** Connect LVPECL Output CLOCK and Output $\overline{\text{CLOCK}}$ outputs to the oscilloscope with matched cables.

NOTE: The readings of the output voltage levels will be offset by -1.3 V from standard LVPECL levels. With this split supply, the device outputs will be parallel terminated by the oscilloscope (or frequency counter) input module’s internal 50 Ω to GND impedance. See the data sheet Figure 10, where $SMAGND = V_{TT} = V_{CC} - 2.0 \text{ V} = 0 \text{ V} = \text{OSCILLOSCOPE GND}$.

An alternative thevenin parallel termination scheme can be accommodated by using the unpopulated Resistor Pads (R76, R77, R78, and R79) provided on the OUTPUT CLOCK and OUTPUT $\overline{\text{CLOCK}}$ lines near the SMA connectors. See AND8020 for additional details. Do not use both thevenin parallel termination scheme and LOW IMPEDANCE (50 Ω) termination schemes on the same output at the same time (double termination).

4. **Trigger:** Ensure the oscilloscope trigger input is properly setup and adjusted and has a 50 Ω termination to ground. The board does not provide 50 Ω source termination resistors. Two possible oscilloscope trigger methods might be
 1. “T” connector from CLKOUT to the trigger of the scope,
 2. Use $\overline{\text{CLKOUT}}$ directly to the trigger.
3. **XTAL/CLK Input:** Determine if the onboard crystal or an external signal reference will be used. Onboard Crystal signal source (27 MHz) is default

ready for use.

NOTE: If an external clock reference is used, then dismount the crystal and connect a clock signal (10 MHz – 50 MHz, 3.3 V_{PP} amplitude) with LEVELS OFFSET -1.3 V: as +2.0 V HIGH and -1.3 V LOW into CLK/XTAL1 (J1). Also short from the bottom side “through hole trace” of INPUT CLOCK to J5 (not J3). Do not drive XTAL2. Termination of the signal generator may be needed with 50 Ω to SMA ground.

4. **Program SDI:** The P, M, and N internal registers may be programmed by (A) the onboard PLD or (B) by using the three line 3.3 V_{PP} amplitude (offset LVTTL/LVCMOS) Serial Data Interface (SDI) consisting of a SERIAL DATA (SDATA) input, a SERIAL CLOCK (SCLOCK) input, and a SERIAL LOAD (SLOAD) as follows:

A. Onboard PLD

1. Insure all 4 of the J12 (441 CONFIG) jumpers are all installed connecting the PLD output to the Device
2. Insure JP1 LED/PLD indicates power is applied to the PLD (LED on);
3. Insure J3 (external CLOCK line from J1) is open, not LOADED, DRIVEN, or shorted;
4. Insure SW5 (LEFT: CUSTOM 441, RIGHT:STANDARD 442) select is set to the LEFT (bypassing SW2, SEL[3:0]). Note LED will light for “CUSTOM FREQUENCIES”.
5. Set SW4, SW6, and SW7 rocker switches to desired P, M, and N programming values: UP =0 LOGIC LOW (LED indicator OFF); DOWN = 1 LOGIC HIGH (LED indicator ON).
6. Load program values by depressing momentary switch SW8, or send a pulse signal (125 ns min) through J13 SMA connector (when installed) with OFFSET LVCMOS/LVTTL LEVELS of +2.0 V HIGH and -1.3 V LOW.

B. External SDI

1. See datasheet DC Table, AC Table, as well as Figures 5 and 6.
2. To use the SDI (serial data input) port, generate and input SCLOCK, SDATA, and SLOAD signals with OFFSET LVCMOS/LVTTL LEVELS of +2.0 V HIGH and -1.3 V LOW. The SCLOCK signal will sample the information presented on SDATA line. Values are loaded and indexed into a 18 bit shift register. The register shifts once per rising edge of the SCLOCK input. The serial input SDATA bits must each meet setup and

hold timing to the respective SCLOCK rising edge as specified in the AC Characteristics section of the datasheet document. The MOST Significant Bit (MSB), P4, is indexed in first followed by P3, P2, P1, N2, N1, N0, M9 through the LEAST Significant Bit (LSB), M0, indexed in last. A Pulse on the SLOAD pin after the SHIFT register is fully indexed (18 clocks) will load and latch the data values for the internal P, M, and N registers. The SLOAD pulse Low to HIGH rising edge transition transfers the data from the SHIFT register to the LATCH register. The SLOAD Pulse HIGH to LOW transition will lock the new data values into the LATCH register.

- 5. Output Enable ON:** Switch SW1 (DOWN) or externally HIGH through J11 (offset LVCMOS/LVTTL of 2.0V HIGH and -1.3 V LOW) to enable the output after setup. LED D3 indicator will be ON to indicate an enabled output.

ALTERNATE STEP 2: LAB SET-UP PROCEDURE FOR SINGLE SUPPLY (INTO HIGH IMPEDANCE PROBES)

- 1. Output Enable OFF:** Switch SW1 (UP) or externally LOW through J11 (standard LVCMOS/LVTTL of 2.0V HIGH and 0.8 V LOW) to disable the output during setup. LED D3 indicator will be off to indicate disabled output.
- 2. Supplies:** Connect a “single” power supply to the evaluation board for 3.3 V operation as follows:
 - VCC (RED banana jack or clip anvil) at +3.3 V
 - SMAGND (YELLOW banana jack or clip anvil) at 0 V
 - DUTGND (BLACK banana jack or clip anvil) 0 V
- 3. Output:** Connect LVPECL OUTPUT CLOCK and OUTPUT $\overline{\text{CLOCK}}$ outputs to the oscilloscope with matched cables. The device outputs will require proper termination. A thevenin parallel termination scheme can be accomplished by populating Resistor Pads (R76, R77, R78, and R79) provided on the OUTPUT CLOCK and OUTPUT $\overline{\text{CLOCK}}$ lines near the SMA connectors. Install 127 Ohm resistors R77 at SG4 and R78 at SG5. Install 83 Ohm resistors R76 at SG2 and R79 at SG2. See AND8020 for additional details. Use HIGH IMPEDANCE (FET) Probes or equipment only. Do not use LOW IMPEDANCE (50 Ω) equipment or probes when using thevenin parallel termination or the signal will be double terminated.
- 4. Trigger:** Ensure the oscilloscope trigger input is setup and adjusted properly. A self triggered

real-time high impedance input scope will not require an external trigger connection.

- 5. XTAL/CLK Input:** Determine if the onboard crystal or an external signal reference will be used. Onboard Crystal signal source is default ready for use.

NOTE: If an external clock reference is used, then dismount crystal and connect a clock signal (10 MHz – 50 MHz) with standard LVTTL/LVCMOS into INPUT CLOCK (J1). Also short from the bottom side “through hole trace” of INPUT CLOCK to J5 (not J3). Do not drive XTAL2. Termination of the signal generator may be needed with 50 Ω to SMA ground.

- 6. Program SDI:** The P, M, and N internal registers may be programmed by (A) the onboard PLD or (B) by using the three line LVTTL/LVCMOS Serial Data Interface (SDI) consisting of a SERIAL DATA (SDATA) input, a SERIAL CLOCK (SCLOCK) input, and a SERIAL LOAD (SLOAD) as follows:

A. Onboard PLD

1. Insure all 4 of the J12 (441 CONFIG) jumpers are all installed connecting the PLD output to the Device
2. Insure JP1 LED/PLD indicates power is applied to the PLD (LED on)
3. Insure J3 (external CLOCK line from J1) is open, not LOADED, DRIVEN, or shorted;
4. Insure SW5 (LEFT: CUSTOM 441, RIGHT:STANDARD 442) select is set to the LEFT (bypassing SW2, SEL[3:0]. Note LED will light for “CUSTOM FREQUENCIES”.
5. Set SW4, SW6, and SW7 rocker switches to desired P, M, and N programming values: UP =0 LOGIC LOW (LED indicator OFF); DOWN = 1 LOGIC HIGH (LED indicator ON).
6. Load program values by depressing momentary switch SW8, or send a pulse signal through J13 SMA connector (when installed) with standard LVTTL/LVCMOS levels.

B. External SDI

1. See datasheet DC Table, AC Table, as well as Figures 5 and 6.
2. To use the SDI serial data input port, generate and input SCLOCK, SDATA, and SLOAD signals with standard LVTTL/LVCMOS levels. The SCLOCK signal will sample the information presented on SDATA line. Values are loaded and indexed into a 18 bit shift register. The register shifts once per rising edge of the SCLOCK input. The serial input SDATA bits must each meet setup and hold

NB4N441MNGEVB

timing to the respective SCLOCK rising edge as specified in the AC Characteristics section of the datasheet document. The MOST Significant Bit (MSB), P4, is indexed in first followed by P3, P2, P1, N2, N1, N0, M9 through the LEAST Significant Bit (LSB), M0, indexed in last. A Pulse on the SLOAD pin after the SHIFT register is fully indexed (18 clocks) will load and latch the data values for the internal P, M, and N registers. The

SLOAD pulse Low to HIGH rising edge transition transfers the data from the SHIFT register to the LATCH register. The SLOAD Pulse HIGH to LOW transition will lock the new data values into the LATCH register.

7. **Output Enable ON:** Switch SW1 (DOWN) or externally HIGH through J11 to enable the output after setup. LED D3 indicator will be ON to indicate an enabled output.

NB4N441MNGEVB

APPENDIX 1: DEVICE AND BOARD INFORMATION

SEE CURRENT DATASHEET

DEVICE PINS:

Pin #	Pin Name	I/O	Open Pin Default	Type	Function
	441				
1	GND	Supply			Negative Power Supply (Ground)
2	NC				No Connect
3	VCCPLL	Supply			Positive supply for the PLL and is connected to +3.3 V
4	NC				No Connect
5	NC				No Connect
6	GND	Supply			Negative Power Supply (Ground)
7	XTAL2	Input			Crystal Oscillator Interface – Crystal Input
8	CLK/XTAL1	Input		CMOS/TTL	Crystal Oscillator Interface – Crystal Input or External Clock Input
9	GND	Supply			Negative Power Supply (Ground)
10	NC				No Connect
11	VCC	Supply			Positive Power Supply
12	VCC	Supply			Positive Power Supply
13	VCC	Supply			Positive Power Supply
14	NC				No Connect
15	SLOAD	Input	L	CMOS/TTL	Serial Load Input
16	SDATA	Input	L	CMOS/TTL	Serial Data Input
17	SCLOCK	Input	L	CMOS/TTL	Serial Clock Input
18	GND	Supply			Negative Power Supply (Ground)
19	GND	Supply			Negative Power Supply (Ground)
20	LOCKED	Output		CMOS/TTL	PLL Locked Indicator
21	OE	Input	H	CMOS/TTL	Synchronous Output Enable. Active HIGH. The Enable is synchronous to the output clock to eliminate the possibility of runt pulses on the CLKOUT outputs.
22	CLKOUT	Output		LVPECL	Differential Clock Output
23	CLKOUT	Output		LVPECL	Differential Clock Output
24	VCC	Supply			Positive Power Supply

Board Pins

Input Clock: An SMA connector (J1) board trace to CLK/XTAL1 device pin contains a gap placed on the board trace at the crystal pin (J5). This board trace and connector are open and not connected to the crystal pin and has no impedance affect on the crystal pin. A short must bridge this gap to connect the INPUT CLOCK SMA to the device CLK/XTAL1 pin. A 50 Ω termination resistor may be added from the board trace from CLK to SMAGND at the SMA connector, or, install a 50 Ω resistor in place of C6.

SW4, 6 and 7 are the M, N, and P SELECT: DIP switches JP1 is an LED power supply jumper provided to disable the LED's and their current. Disabling the LEDs will allow measuring only the device power supply current.

Output CLOCK and Output CLOCK: The outputs have equal length board traces with SMA connectors, J2 & J4. Use matched cables to connect the outputs to an oscilloscope or frequency counter. Alternative connection pads are supplied for installation of a Thevenin termination scheme.

Serial Pins (NB4N441) SCLOCK, SDATA and SLOAD pins have board traces connected to SMA connectors J10, J9 and J7 for external control. There are no 50 Ω termination resistors on these nodes. If signal sources requiring output termination are needed to drive SCLOCK, SDATA and SLOAD, a 50 Ω resistor can be added, from the board trace at the SMA conductor to SMA ground.

Output Enable: The Output Enable function is carried out manually with the switch, SW1, or externally via SMA connector J11, and observing the OUTPUT CLOCK & OUTPUT CLOCK CLKOUT pins.

PLL LOCKED There are two convenient PLL indicator LEDs, green for when the device is PLL LOCKED and red for PLL not LOCKED.

LED/PLD Power: The LED and PLD power can be disabled by leaving JP1 open or removing shunt from JP1.

NB4N441MNGEVB

APPENDIX 2: SCHEMATICS

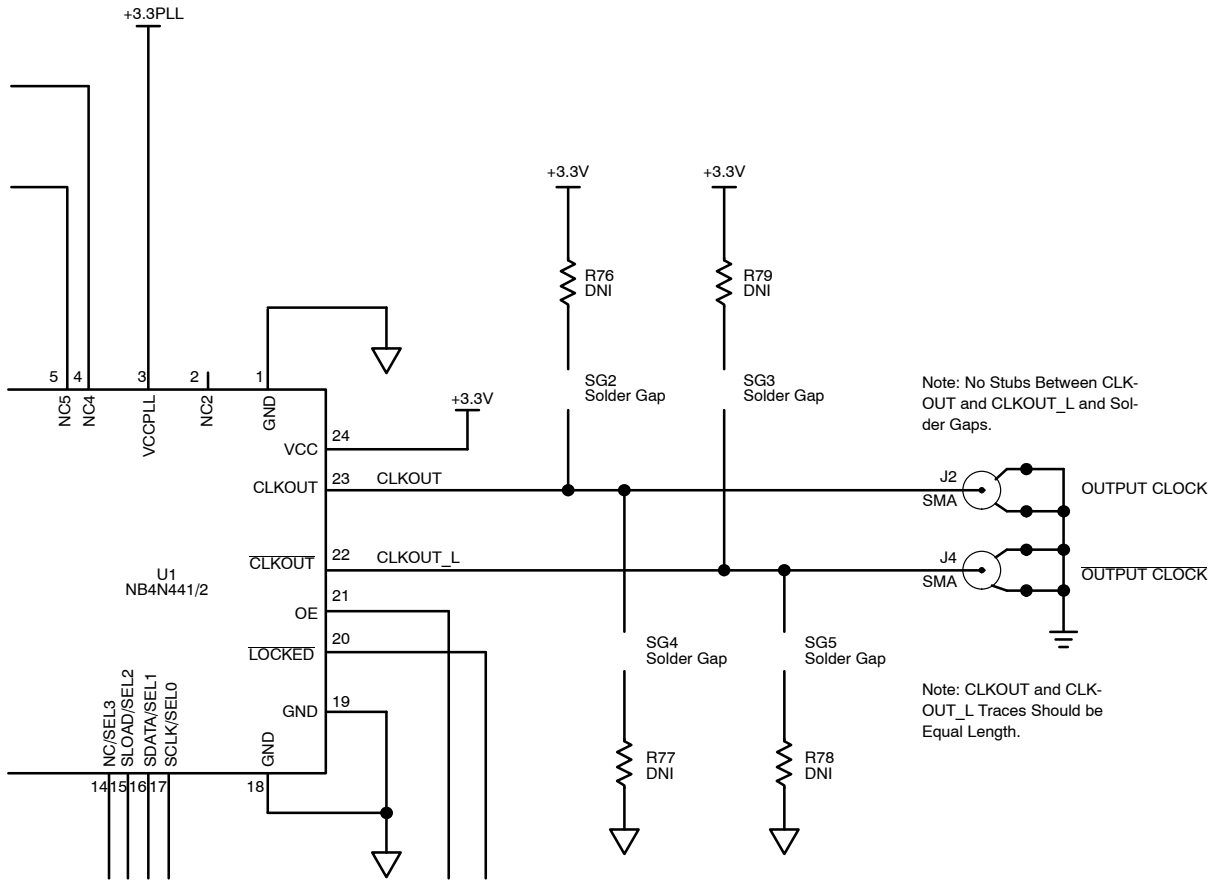

Figure 3. Outputs

NB4N441MNGEVB

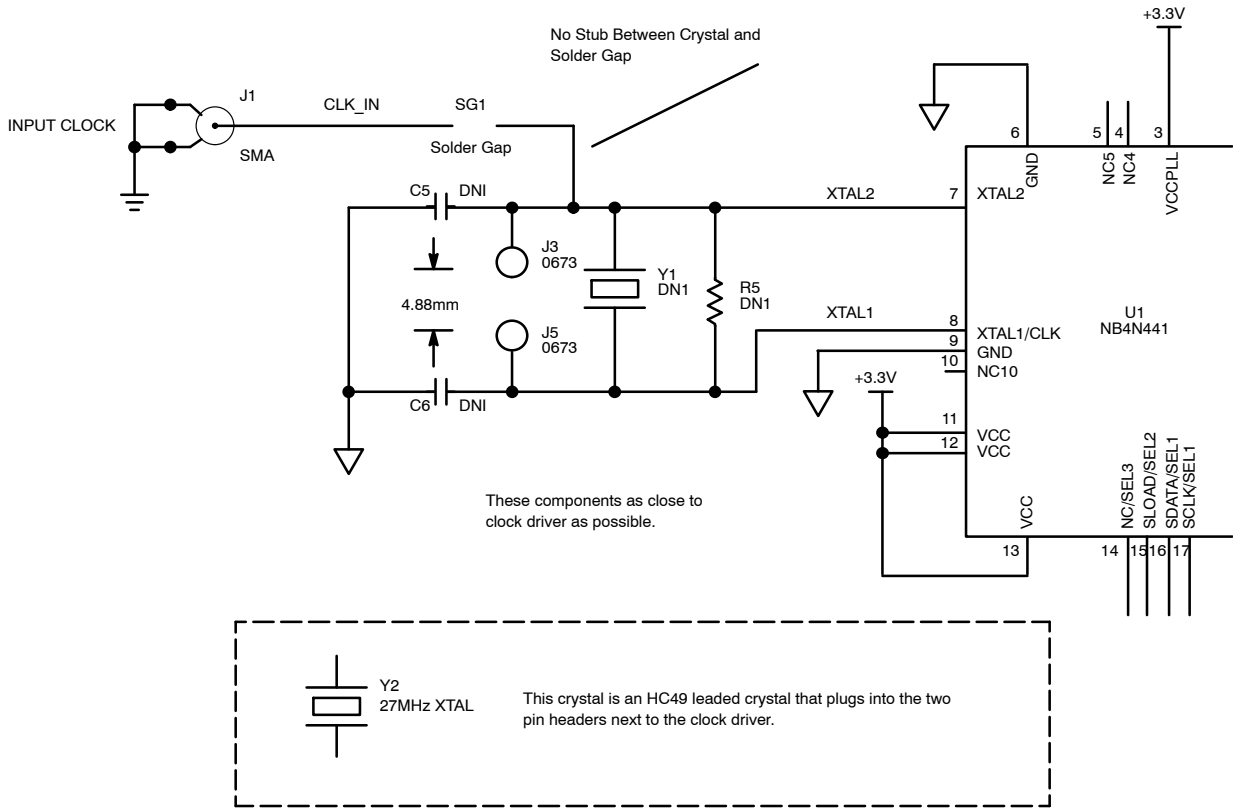

Figure 4. Input Clock and Crystal

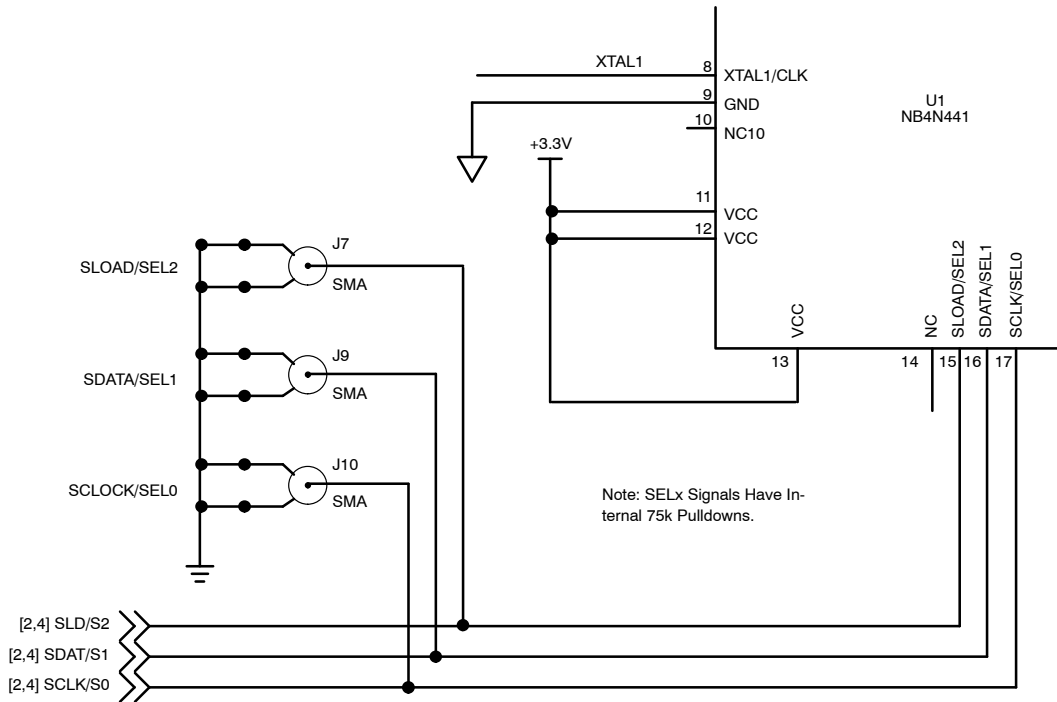

Figure 5. SDI Inputs

NB4N441MNGEVB

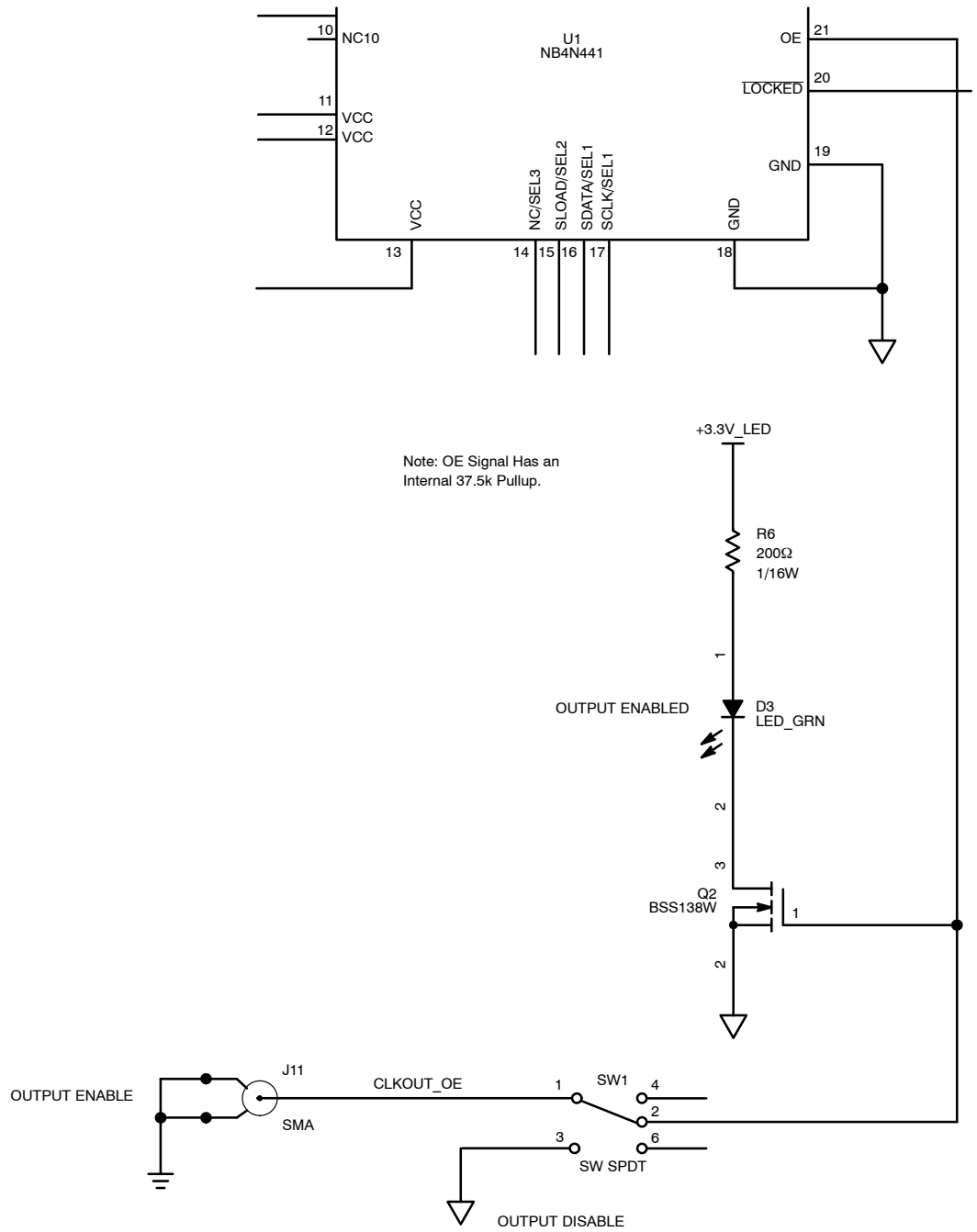

Figure 6. Output Enable

NB4N441MNGEVB

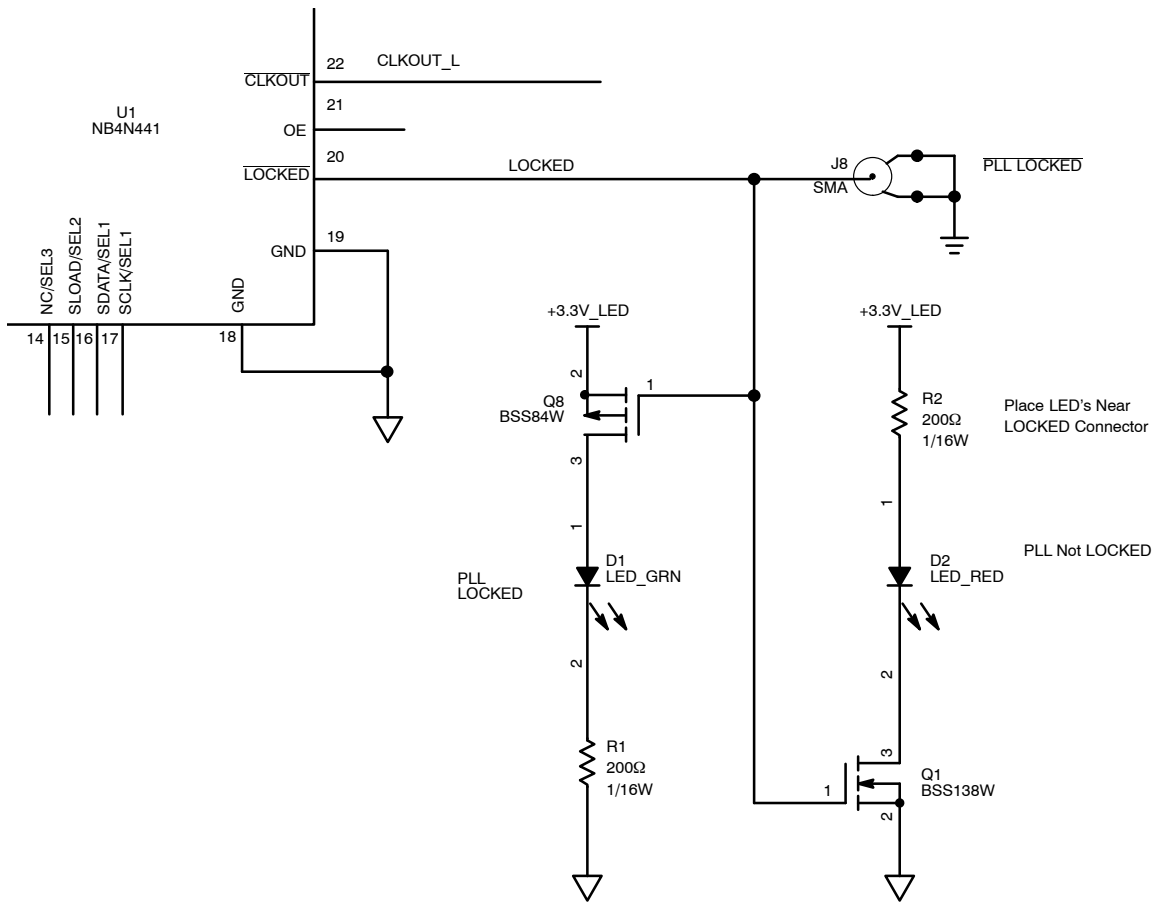

Figure 7. Output LOCKED/Not LOCKED

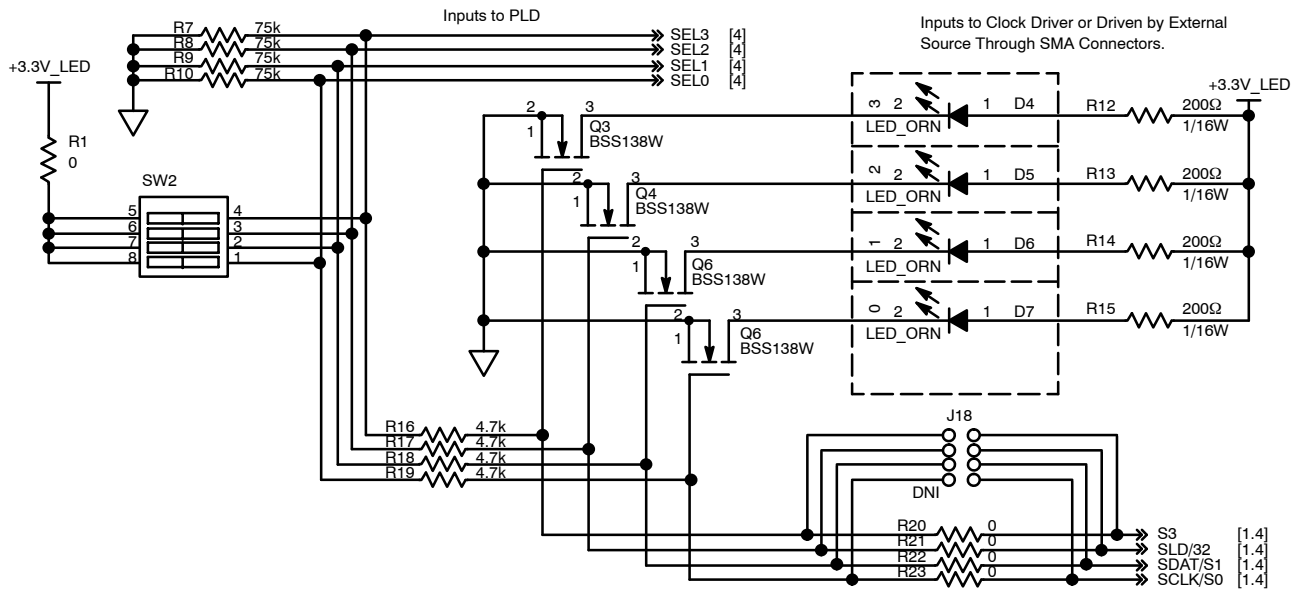

Figure 8. Inputs to PLD

NB4N441MNGEVB

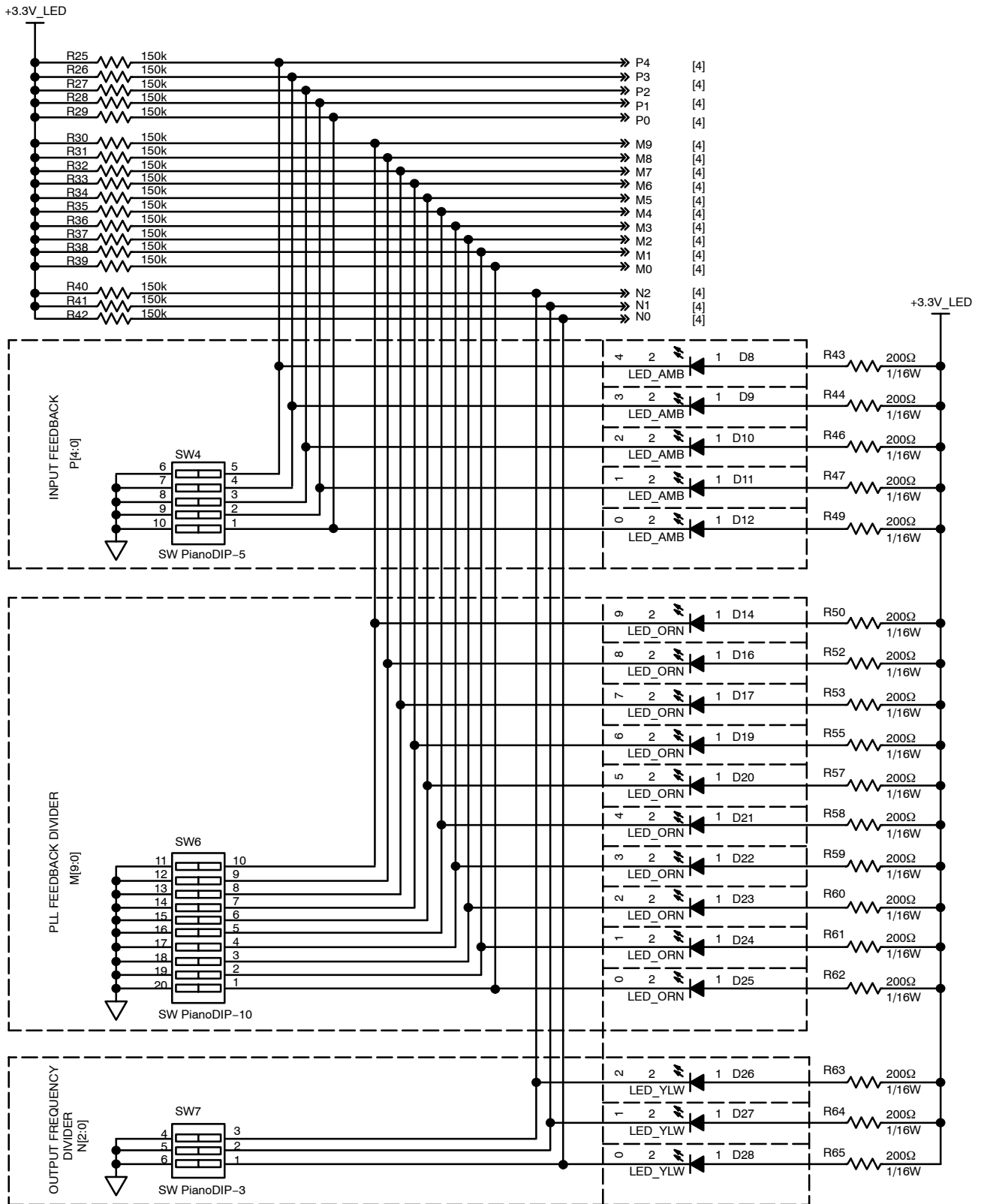

Figure 9. Switches and LED

NB4N441MNGEVB

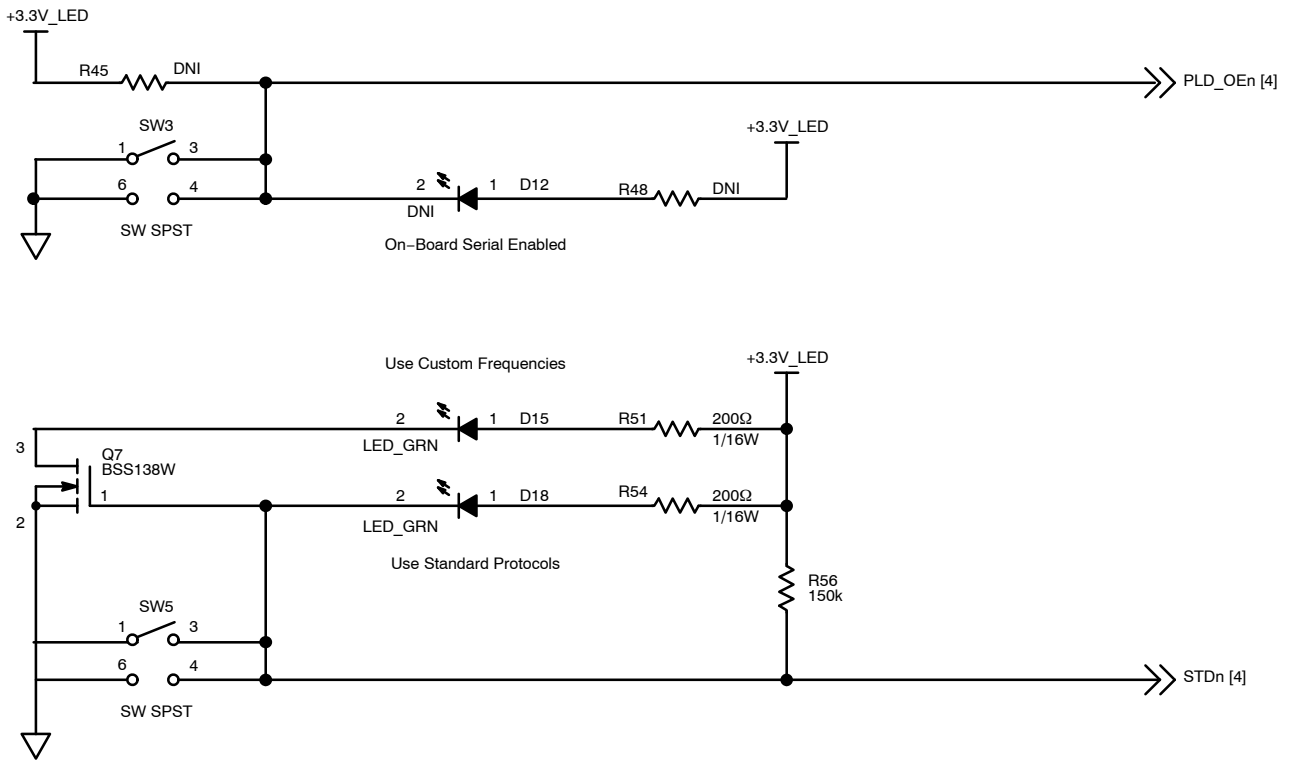

Figure 10. Output Enable

NB4N441MNGEVB

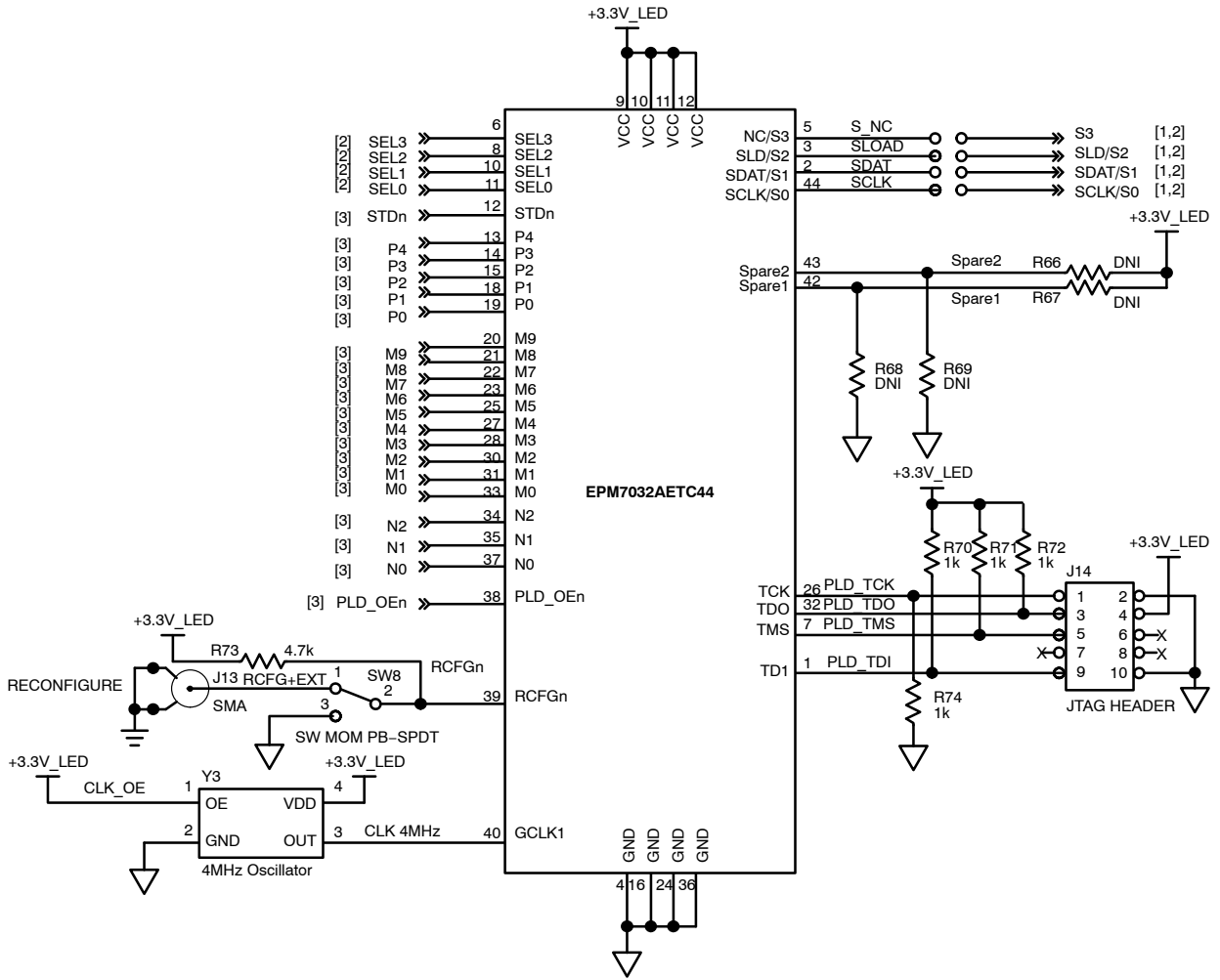

Figure 11. PLD

NB4N441MNGEVB

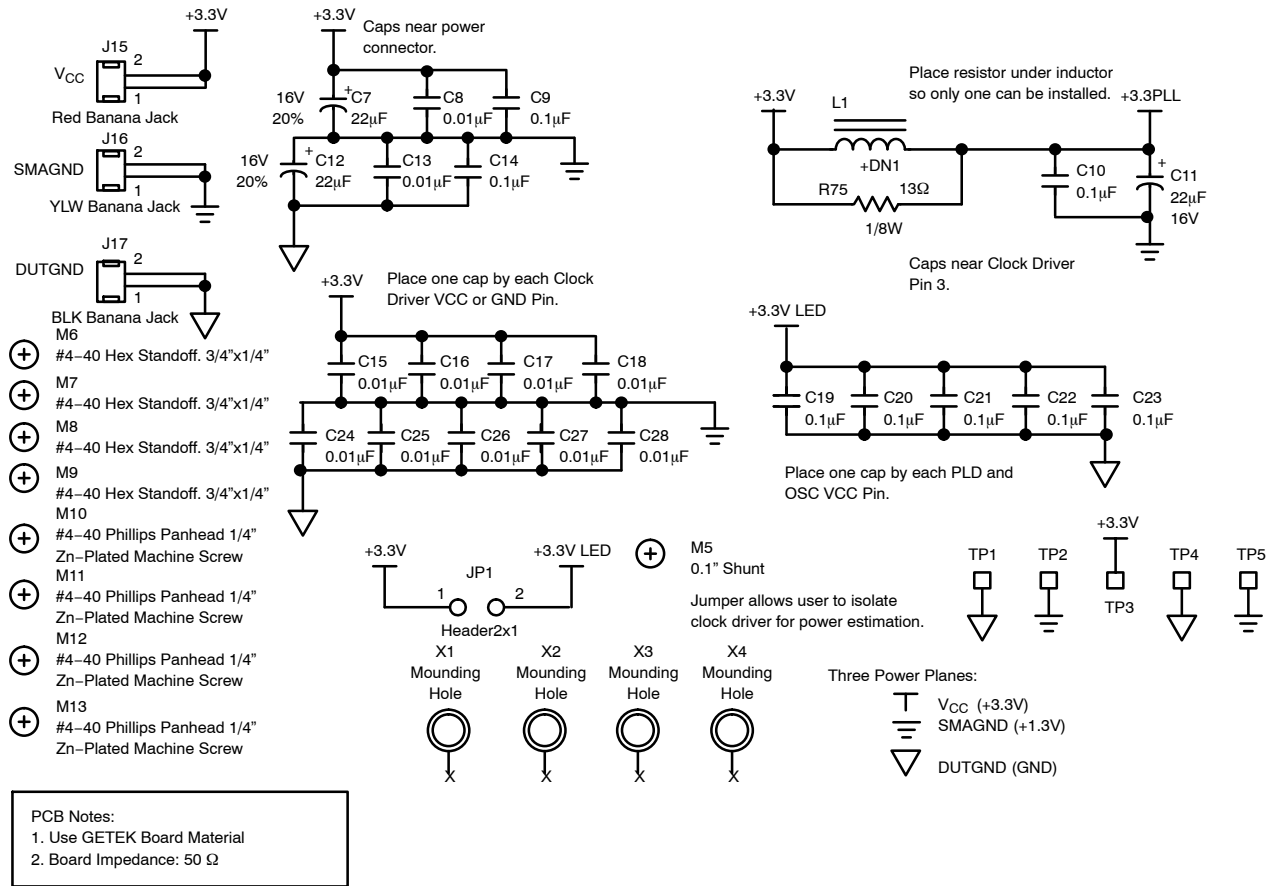

Figure 12. Power and Hardware

NB4N441MNGEVB

APPENDIX 3: BILL OF MATERIALS, LAMINATION STACKUP, AND ASSEMBLY NOTES

Item	Mfg Part #	Description	Manufacturer	Reference	Vendor Part #	Vendor	Qty
1		DNI		C1,C2,R3,C3,R4,C4,R5,C5,C6,R45,R48,R66,R67,R68,R69,R76,R77,R78,R79			19
2	T494D226K016AS	22 μ F	Kemet	C7,C11,C12	399-1782-1-ND	Digikey	3
3	C0603C103K5RACTU	0.01 μ F	Kemet	C8,C10,C13,C15,C16,C17,C18,C24,C25,C26,C27,C28	399-1091-1-ND	Digikey	12
4	ECJ-1VB1C104K	0.1 μ F	Panasonic	C9,C14	PCC1762CT-ND	Digikey	2
5	ECJ-1VB1C104K	0.1 μ F	Panasonic	C19,C20,C21,C22,C23	PCC1762CT-ND	Digikey	5
6	LTST_C190GKT	LED_GRN	Lite-On	D3,D1	160-1183-1-ND	Digikey	2
7	LTST_C190CKT	LED_RED	Lite-On	D2	160-1181-1-ND	Digikey	1
8	LTST_C190EKT	LED_ORN	Lite-On	D4,D5,D6,D7	160-1182-1-ND	Digikey	4
9	LTST_C190AKT	LED_AMB	Lite-On	D8,D9,D10,D11,D13	160-1180-1-ND	Digikey	5
10		DNI		D12			1
11	LTST_C190EKT	LED_ORN	Lite-On	D14,D16,D17,D19,D20,D21, D22,D23,D24,D25	160-1182-1-ND	Digikey	10
12	LTST_C190GKT	LED_GRN	Lite-On	D15,D18	160-1183-1-ND	Digikey	2
13	LTST_C190YKT	LED_YLW	Lite-On	D26,D27,D28	160-1184-1-ND	Digikey	3
14	22-03-2021	Header2x1	Molex	JP1	WM4000-ND	Digikey	1
15	142-0701-801	SMA	Johnson Components	J1,J2,J4,J7,J8,J9,J10,J11	J502-ND	Digikey	8
16	0673-0-15-01-30-02-10-0	0673	Mill-Max	J3,J5			2
17	142-0701-801	SMA	Johnson Components	J6	J502-ND	Digikey	1
18	10-89-1081	8-pin Header	Molex	J12	WM6808-ND	Digikey	1
19	142-0701-801	SMA	Johnson Components	J13	J502-ND	Digikey	1
20	10-89-1101	JTAG HEADER	Molex	J14	WM6810-ND	Digikey	1
21	571-0500	RED BANANA JACK	Deltron	J15	150-039	Farnell / Newark	1
22	571-0700	YLW BANANA JACK	Deltron	J16	150-043	Farnell / Newark	1
23	571-0100	BLK BANANA JACK	Deltron	J17	150-040	Farnell / Newark	1
24	10-89-1081	DNI	Molex	J18	WM6808-ND	Digikey	1
25	CDRH74-102MC	DNI	Sumida	L1	308-1197-1-ND	Digikey	1
26	382811-5	0.1" Shunt	AMP/Tyco	M1,M2,M3,M4	A26229-ND	Digikey	4
27	382811-5	0.1" Shunt	AMP/Tyco	M5	A26229-ND	Digikey	1
28	1895	#4-40 Hex Standoff, 3/4"x1/4"	Keystone	M6,M7,M8,M9	1895K-ND	Digikey	4
29	PMS 440 0025 PH	#4-40 Phillips Panhead 1/4" Zn-plated Machine Screw	Building Fasteners	M10,M11,M12,M13	H342-ND	Digikey	4
30	50-000-00306	24 LD QFN GCI Flex Socket	M&M Specialties	M14	50-000-00306	M&M Specialties	1
31	BSS138W-7	BSS138W	Diodes Inc.	Q1,Q2,Q3,Q4,Q5,Q6	BSS138WDICT-ND	Digikey	6
32	BSS138W-7	BSS138W	Diodes Inc.	Q7	BSS138WDICT-ND	Digikey	1
33	BSS84W-7	BSS84W	Diodes Inc.	Q8	621-BSS84W	Mouser	1
34	ERJ-3GEYJ221V	200 Ω	Panasonic	R1,R2,R6,R12,R13,R14,R15	P220GCT-ND	Digikey	7

NB4N441MNGEVB

Item	Mfg Part #	Description	Manufacturer	Reference	Vendor Part #	Vendor	Qty
35	ERJ-3GEYJ753V	75k	Panasonic	R7,R8,R9,R10	P75KGCT-ND	Digikey	4
36	ERJ-3GEY0R00V	0.0	Panasonic	R11	P0.0GCT-ND	Digikey	1
37	ERJ-3GEYJ472V	4.7k	Panasonic	R16,R17,R18,R19	P4.7KGCT-ND	Digikey	4
38	ERJ-3GEY0R00V	0.0	Panasonic	R20,R21,R22,R23	P0.0GCT-ND	Digikey	4
39	ERJ-3GEY0R00V	0.0	Panasonic	R24	P0.0GCT-ND	Digikey	1
40	ERJ-3GEYJ154V	150k	Panasonic	R25,R26,R27,R28,R29,R30,R31,R32,R33,R34,R35,R36,R37,R38,R39,R40,R41,R42,R56	P150KGCT-ND	Digikey	19
41	ERJ-3GEYJ221V	200Ω	Panasonic	R43,R44,R46,R47,R49,R50,R51,R52,R53,R54,R55,R57,R58,R59,R60,R61,R62,R63,R64,R65	P220GCT-ND	Digikey	20
42	ERJ-3GEYJ102V	1K	Panasonic	R70,R71,R72,R74	P1.0KGCT-ND	Digikey	4
43	ERJ-3GEYJ472V	4.7k	Panasonic	R73	P4.7KGCT-ND	Digikey	1
44	ERJ-6GEYJ130V	13Ω	Panasonic	R75	P13ACT-ND	Digikey	1
45	GT11MSCKETR	SW SPDT	C&K	SW1	CKN1099CT-ND	Digikey	1
46	76PSB04	SW DIP-4	Grayhill	SW2	GH1215-ND	Digikey	1
47		DNI		SW3			1
48	76PSB05	SW PianoDIP-5	Grayhill	SW4	GH1216-ND	Digikey	1
49	GT12MSCKETR	SW SPST	C&K	SW5	CKN1100CT-ND	Digikey	1
50	76PSB10	SW PianoDIP-10	Grayhill	SW6	GH1221-ND	Digikey	1
51	76PSB03	SW PianoDIP-3	Grayhill	SW7	GH1214-ND	Digikey	1
52	EP12SD1SAKE	SW MOM PB-SPDT	C&K	SW8	CKN4056CT-ND	Digikey	1
53	5015	TP_SMT_KEYSTONE	Keystone	TP1,TP2,TP3,TP4,TP5	5015KCT-ND	Digikey	5
54	NB4N441	NB4N441	ON Semiconductor	U1			1
55	EPM7032AETC44-10	EPM7032AETC44	Altera	U2	EPM7032AETC44-10	Arrow	1
56		Mounting Hole		X1,X2,X3,X4			4
57	HCM49-21.47727MABJT	DNI	Citizen	Y1	300-6143-1-ND	Digikey	1
58	HC49US27.000MABJ	27MHz XTAL	Citizen	Y2	300-6050-ND	Digikey	1
59	CSX750FBC4.000000MTR	4MHz Oscillator	Citizen	Y3	300-7232-1-ND	Digikey	1

NB4N441MNGEVB

LAMINATION STACK

- L1 Signal
- L2 SMAGND
- L3 V_{CC} and DUTGND
- L4 DUTGND and Signal

LAMINATION DIAGRAM					
Layer Number	Layer Name	Copper Thickness	Dielectric Thickness	Layer Material	Trace Width
1	TOP	1/2 OZ.			0.012
			0.006	GETEK	
2	SMAGND	1 OZ.			---
			Adjust	GETEK	
3	PWR	1 OZ.			---
			0.006	GETEK	
4	DUTGND	1/2 OZ.			0.011
FINISHED PCB THICKNESS TO BE:			0.64 ±0.003		

ASSEMBLY NOTES:

Notes (Unless Otherwise Specified)

Material:

- GETEK Laminate Epoxy/Polyphenylene Oxide Resin Type NEMA FR-4 (IPC-L-1088/04). See Layer Table. Inner Layers: 1 oz. Copper clad
Outer Layers: 1/2 oz. Copper Foil Plated to 1 1/2 oz finished.
- Refer to Stacking Diagram for Finished Board Thickness.

Tooling:

- Photo etch circuitry per artwork drill locations controlled by drill file.drl fabrication print.
- The dielectric thickness of the controlled impedance layers is for reference only. Final acceptance shall be determined by these layer pairs having a characteristic impedance of $52.5 \Omega \pm 10\%$. The vendor can make width adjustments on only the critical conductor widths of ± 0.0005 . All other adjustments must have prior approval from Baldwin Tech Layer Grouping (1.2).
- Finished conductor width to be 0.012".

Finish:

- Plating Specification: Electrodeposited hard gold plate, Type 1 (99.7% min gold) Grade C (Knoop Hardness 130-200), Class 1 (50-100 micro-inches thick) in accordance with MIL-G-4520C and ANSI/IPC-A-6000. Section 4.0 (surface plating acceptability requirements), Class 3 (50-100

micro-inches thick) over electrodeposited nickel plate in accordance with ANSI/IPC-A-6000, Section 4.0, Class 3 (200-600 micro-inches thick).

- Drill sizes are finished. Plated through holes to have a minimum barrel plating of 0.0008 in.
- Board twist and warp not to exceed 0.005 in (5%) per linear inch. Front to back registration to be within 0.003 in.
- True position tolerance shall be determined by a minimum annular ring of 0.005 in.
- Plated holes shall not be rough or irregular so as to hinder proper solder wicking.
- Soldermask: Green LPI: B0
- Apply Legend (SILKSCREEN) to both sides using a nonconductive, white, Epoxy based ink per artwork.
- No board shop logo on board.
- Each PCB shall be serialized, in legend, in the area shown, as follow: 0005-1-1 (Sequential Number (assigned per panel)-Panel Number (assigned per log)-Year and Week).

Testing:

- Final Electrical Test shall be performed per provided IPC-356 netlist. The PCB shall have a verification stamp. Connectivity to be verified against IPC format net list.
- A TDR report for each layer shall be provided by vendor at time of shipment.

onsemi, **Onsemi**, and other names, marks, and brands are registered and/or common law trademarks of Semiconductor Components Industries, LLC dba "**onsemi**" or its affiliates and/or subsidiaries in the United States and/or other countries. **onsemi** owns the rights to a number of patents, trademarks, copyrights, trade secrets, and other intellectual property. A listing of **onsemi**'s product/patent coverage may be accessed at www.onsemi.com/site/pdf/Patent-Marking.pdf. **onsemi** is an Equal Opportunity/Affirmative Action Employer. This literature is subject to all applicable copyright laws and is not for resale in any manner.

The evaluation board/kit (research and development board/kit) (hereinafter the "board") is not a finished product and is not available for sale to consumers. The board is only intended for research, development, demonstration and evaluation purposes and will only be used in laboratory/development areas by persons with an engineering/technical training and familiar with the risks associated with handling electrical/mechanical components, systems and subsystems. This person assumes full responsibility/liability for proper and safe handling. Any other use, resale or redistribution for any other purpose is strictly prohibited.

THE BOARD IS PROVIDED BY ONSEMI TO YOU "AS IS" AND WITHOUT ANY REPRESENTATIONS OR WARRANTIES WHATSOEVER. WITHOUT LIMITING THE FOREGOING, ONSEMI (AND ITS LICENSORS/SUPPLIERS) HEREBY DISCLAIMS ANY AND ALL REPRESENTATIONS AND WARRANTIES IN RELATION TO THE BOARD, ANY MODIFICATIONS, OR THIS AGREEMENT, WHETHER EXPRESS, IMPLIED, STATUTORY OR OTHERWISE, INCLUDING WITHOUT LIMITATION ANY AND ALL REPRESENTATIONS AND WARRANTIES OF MERCHANTABILITY, FITNESS FOR A PARTICULAR PURPOSE, TITLE, NON-INFRINGEMENT, AND THOSE ARISING FROM A COURSE OF DEALING, TRADE USAGE, TRADE CUSTOM OR TRADE PRACTICE.

onsemi reserves the right to make changes without further notice to any board.

You are responsible for determining whether the board will be suitable for your intended use or application or will achieve your intended results. Prior to using or distributing any systems that have been evaluated, designed or tested using the board, you agree to test and validate your design to confirm the functionality for your application. Any technical, applications or design information or advice, quality characterization, reliability data or other services provided by **onsemi** shall not constitute any representation or warranty by **onsemi**, and no additional obligations or liabilities shall arise from **onsemi** having provided such information or services.

onsemi products including the boards are not designed, intended, or authorized for use in life support systems, or any FDA Class 3 medical devices or medical devices with a similar or equivalent classification in a foreign jurisdiction, or any devices intended for implantation in the human body. You agree to indemnify, defend and hold harmless **onsemi**, its directors, officers, employees, representatives, agents, subsidiaries, affiliates, distributors, and assigns, against any and all liabilities, losses, costs, damages, judgments, and expenses, arising out of any claim, demand, investigation, lawsuit, regulatory action or cause of action arising out of or associated with any unauthorized use, even if such claim alleges that **onsemi** was negligent regarding the design or manufacture of any products and/or the board.

This evaluation board/kit does not fall within the scope of the European Union directives regarding electromagnetic compatibility, restricted substances (RoHS), recycling (WEEE), FCC, CE or UL, and may not meet the technical requirements of these or other related directives.

FCC WARNING – This evaluation board/kit is intended for use for engineering development, demonstration, or evaluation purposes only and is not considered by **onsemi** to be a finished end product fit for general consumer use. It may generate, use, or radiate radio frequency energy and has not been tested for compliance with the limits of computing devices pursuant to part 15 of FCC rules, which are designed to provide reasonable protection against radio frequency interference. Operation of this equipment may cause interference with radio communications, in which case the user shall be responsible, at its expense, to take whatever measures may be required to correct this interference.

onsemi does not convey any license under its patent rights nor the rights of others.

LIMITATIONS OF LIABILITY: **onsemi** shall not be liable for any special, consequential, incidental, indirect or punitive damages, including, but not limited to the costs of requalification, delay, loss of profits or goodwill, arising out of or in connection with the board, even if **onsemi** is advised of the possibility of such damages. In no event shall **onsemi**'s aggregate liability from any obligation arising out of or in connection with the board, under any theory of liability, exceed the purchase price paid for the board, if any.

The board is provided to you subject to the license and other terms per **onsemi**'s standard terms and conditions of sale. For more information and documentation, please visit www.onsemi.com.

ADDITIONAL INFORMATION

TECHNICAL PUBLICATIONS:

Technical Library: www.onsemi.com/design/resources/technical-documentation
onsemi Website: www.onsemi.com

ONLINE SUPPORT: www.onsemi.com/support

For additional information, please contact your local Sales Representative at www.onsemi.com/support/sales