

Preface

Atmel® maXTouch® Xplained Pro is an extension board to the Atmel Xplained Pro evaluation platform. The board enables the user to experiment with user interface applications with maXTouch and LCD.



Table of Contents

Preface.....	1
1. Introduction.....	3
1.1. Features.....	3
1.2. Kit Overview.....	3
2. Getting Started.....	5
2.1. Xplained Pro Quick Start.....	5
2.2. Connecting maXTouch Xplained Pro to the Xplained Pro MCU Board.....	5
2.3. Design Documentation and Relevant Links.....	5
3. Xplained Pro.....	7
3.1. Hardware Identification System.....	7
3.2. Xplained Pro Headers and Connectors.....	7
3.2.1. Xplained Pro Standard Extension Header.....	7
3.2.2. Xplained Pro LCD Extension Connector.....	8
4. Hardware User Guide.....	11
4.1. Electrical Characteristics.....	11
4.2. Headers and Connectors.....	11
4.2.1. maXTouch Xplained Pro Extension Headers.....	11
4.3. Peripherals.....	14
4.3.1. maXTouch Capacitive Touch Controller.....	14
4.3.2. Interface Selector.....	14
4.4. Mounting.....	14
4.4.1. Board Stacking Options.....	14
5. Hardware Revision History and Known Issues.....	18
5.1. Identifying Product ID and Revision.....	18
5.2. Revision 2.....	18
6. Document Revision History.....	19
7. Evaluation Board/kit Important Notice.....	20

1. Introduction

1.1. Features

- 4.3" Display module
 - ILI9488 LCD Driver
 - 320x480 Resolution
 - Parallel interface (up to 18-bit)
 - Parallel RGB interface
 - 3- and 4-wire SPI interface
 - maXTouch capacitive touch screen controller
- Xplained Pro hardware identification system
- Kit Contents
 - One 4.3" display module
 - One 50-way Flexible Flat Cable (FFC)
 - One 20-way Ribbon Cable
 - Four mounting screws and eight threaded spacers

1.2. Kit Overview

Atmel maXTouch Xplained Pro is an extension board for the Xplained Pro platform with a 320x480 RGB LCD and a capacitive touch sensor with a maXTouch controller. The LCD can be controlled via different interfaces, including 3- and 4-wire SPI, Parallel and RGB Parallel interface mode using the DIP-switch to select the interface. The maXTouch Xplained Pro kit connects to any Xplained Pro standard extension header on any Xplained Pro MCU board using the 20-pin header, but is limited to 3- and 4-wire SPI mode. maXTouch Xplained Pro also features a standard Xplained Pro LCD connector (FFC), which enables use of the parallel interfaces. Both connections features SPI interface for the LCD and I²C for the maXTouch device.

Figure 1-1. maXTouch Xplained Pro Extension Board

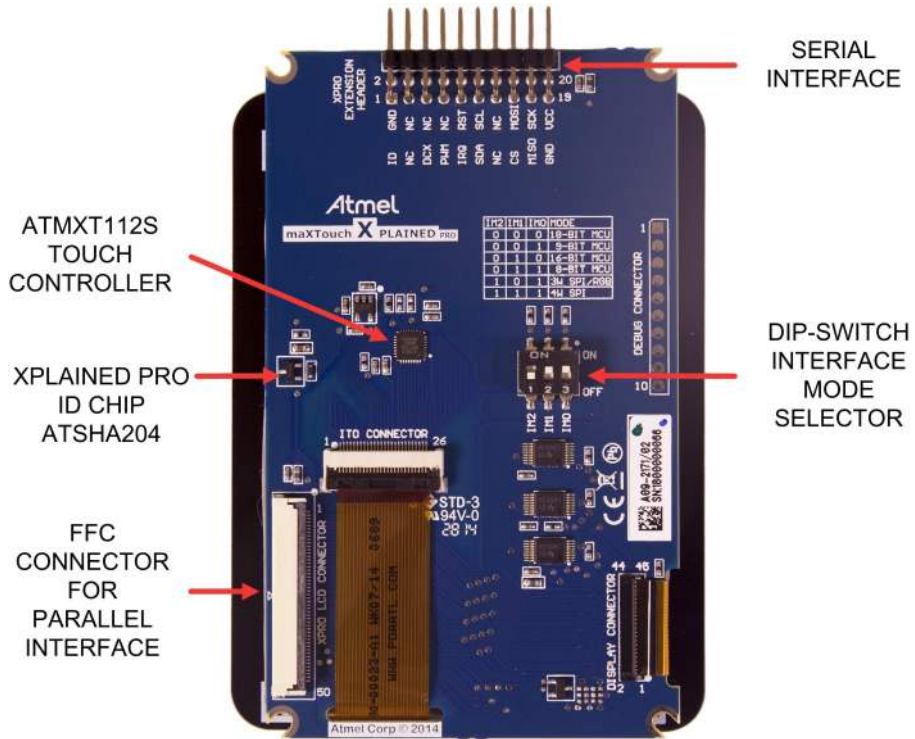

2. Getting Started

2.1. Xplained Pro Quick Start

Steps to start exploring the Atmel Xplained Pro platform:

1. Download [Atmel Studio](#).
2. Launch Atmel Studio.
3. Connect maXTouch Xplained Pro to an Xplained Pro MCU board and connect a USB cable to the DEBUG USB port on the Xplained Pro MCU board.

When the Xplained Pro MCU kit is connected to your computer for the first time, the operating system will perform a driver software installation. The driver file supports both 32- and 64-bit versions of Microsoft® Windows® XP, Windows Vista®, Windows 7, and Windows 8.

Once the Xplained Pro MCU board is powered the green power LED will be lit and Atmel Studio will auto detect which Xplained Pro MCU- and extension board(s) are connected. Atmel Studio will present relevant information like datasheets and kit documentation. The kit landing page in Atmel Studio also has the option to launch Atmel Software Framework (ASF) example applications for the kit. The target device is programmed and debugged by the on-board Embedded Debugger and therefore no external programmer or debugger tool is needed.

2.2. Connecting maXTouch Xplained Pro to the Xplained Pro MCU Board

Atmel maXTouch Xplained Pro has been designed to be connected to the Xplained Pro header marked EXT3. However, it is compatible with all Xplained Pro EXT headers. Refer to the pin-out of your Xplained Pro evaluation kit to find out which Xplained Pro EXT headers that can be used. The Flexible Flat Cable (FFC) connector can be used if parallel interface from the MCU to the display is used on kits featuring the Xplained Pro LCD connector. (Only one cables should be connected at the same time.)

Once the Xplained Pro MCU board is powered the green power LED will be lit and Atmel Studio will auto detect which Xplained Pro MCU- and extension board(s) that is connected. Atmel Studio will present relevant information like datasheets and kit documentation. The kit landing page in Atmel Studio also have the option to launch Atmel Software Framework (ASF) example applications for the kit. The target device is programmed and debugged by the on-board Embedded Debugger. No external programmer or debugger tool is needed.

2.3. Design Documentation and Relevant Links

The following list contains links to the most relevant documents and software for maXTouch Xplained Pro:

- [Xplained Pro products](#) - Atmel Xplained Pro is a series of small-sized and easy-to-use evaluation kits for Atmel microcontrollers and other Atmel products. It consists of a series of low-cost MCU boards for evaluation and demonstration of features and capabilities of different MCU families.
- [Atmel Studio](#) - Free Atmel IDE for development of C/C++ and assembler code for Atmel microcontrollers.
- [EDBG User Guide](#) - User guide containing more information about the on-board Embedded Debugger.
- [Atmel Data Visualizer](#) - Atmel Data Visualizer is a program used for processing and visualizing data. Data Visualizer can receive data from various sources such as the Embedded Debugger Data Gateway Interface found on Xplained Pro boards and COM ports.

- [Design Documentation](#) - Package containing CAD source, schematics, BOM, assembly drawings, 3D plots, layer plots etc.
- [Hardware Users Guide in PDF format](#) - PDF version of this User Guide.
- [maXTouch Xplained Pro on the Atmel website](#) - Atmel website link.

3. Xplained Pro

Xplained Pro is an evaluation platform that provides the full Atmel microcontroller experience. The platform consists of a series of Microcontroller (MCU) boards and extension boards, which are integrated with Atmel Studio, have Atmel Software Framework (ASF) drivers and demo code, support data streaming, and more. Xplained Pro MCU boards support a wide range of Xplained Pro extension boards, which are connected through a set of standardized headers and connectors. Each extension board has an identification (ID) chip to uniquely identify which boards are connected to an Xplained Pro MCU board. This information is used to present relevant user guides, application notes, datasheets, and example code through Atmel Studio.

3.1. Hardware Identification System

All Xplained Pro compatible extension boards have an Atmel ATSHA204 CryptoAuthentication™ chip mounted. This chip contains information that identifies the extension with its name and some extra data. When an Xplained Pro extension is connected to an Xplained Pro MCU board the information is read and sent to Atmel Studio. The Atmel Kits extension, installed with Atmel Studio, will give relevant information, code examples, and links to relevant documents. The table below shows the data fields stored in the ID chip with example content.

Table 3-1. Xplained Pro ID Chip Content

Data field	Data type	Example content
Manufacturer	ASCII string	Atmel\0'
Product Name	ASCII string	Segment LCD1 Xplained Pro\0'
Product Revision	ASCII string	02\0'
Product Serial Number	ASCII string	1774020200000010\0'
Minimum Voltage [mV]	uint16_t	3000
Maximum Voltage [mV]	uint16_t	3600
Maximum Current [mA]	uint16_t	30

3.2. Xplained Pro Headers and Connectors

3.2.1. Xplained Pro Standard Extension Header

All Xplained Pro kits have one or more dual row, 20-pin, 100mil extension header. Xplained Pro MCU boards have male headers, while Xplained Pro extensions have their female counterparts. Note that all pins are not always connected. All connected pins follow the defined pin-out description in the table below.

The extension headers can be used to connect a variety of Xplained Pro extensions to Xplained Pro MCU boards or to access the pins of the target MCU on Xplained Pro MCU boards directly.

Table 3-2. Xplained Pro Standard Extension Header

Pin number	Name	Description
1	ID	Communication line to the ID chip on an extension board
2	GND	Ground
3	ADC(+)	Analog to digital converter, alternatively positive part of differential ADC
4	ADC(-)	Analog to digital converter, alternatively negative part of differential ADC
5	GPIO1	General purpose I/O
6	GPIO2	General purpose I/O
7	PWM(+)	Pulse width modulation, alternatively positive part of differential PWM
8	PWM(-)	Pulse width modulation, alternatively negative part of differential PWM
9	IRQ/GPIO	Interrupt request line and/or general purpose I/O
10	SPI_SS_B/ GPIO	Slave select for SPI and/or general purpose I/O
11	I ² C_SDA	Data line for I ² C interface. Always implemented, bus type.
12	I ² C_SCL	Clock line for I ² C interface. Always implemented, bus type.
13	UART_RX	Receiver line of target device UART
14	UART_TX	Transmitter line of target device UART
15	SPI_SS_A	Slave select for SPI. Should preferably be unique.
16	SPI_MOSI	Master out slave in line of serial peripheral interface. Always implemented, bus type.
17	SPI_MISO	Master in slave out line of serial peripheral interface. Always implemented, bus type.
18	SPI_SCK	Clock for serial peripheral interface. Always implemented, bus type.
19	GND	Ground
20	VCC	Power for extension board

3.2.2. Xplained Pro LCD Extension Connector

The LCD connector provides the ability to connect to display extensions that have a parallel interface. The connector implements signals for a MCU parallel bus interface and a LCD controller interface as well as signals for a touch controller. The connector pin-out definition is shown in [Table 3-3 Xplained Pro LCD Connector](#) on page 9. Note that usually only one display interface is implemented, either the LCD controller or the MCU bus interface.

A FPC/FFC connector with 50 pins and 0.5mm pitch is used for the LCD connector. The connector XF2M-5015-1A from Omron is used on several Xplained Pro designs and can be used as a reference.

Table 3-3. Xplained Pro LCD Connector

Pin number	Name	RGB interface description	MCU interface description
1	ID		Communication line to the ID chip on an extension board
2	GND	Ground	
3	D0	Data line	
4	D1	Data line	
5	D2	Data line	
6	D3	Data line	
7	GND	Ground	
8	D4	Data line	
9	D5	Data line	
10	D6	Data line	
11	D7	Data line	
12	GND	Ground	
13	D8	Data line	
14	D9	Data line	
15	D10	Data line	
16	D11	Data line	
17	GND	Ground	
18	D12	Data line	
19	D13	Data line	
20	D14	Data line	
21	D15	Data line	
22	GND	Ground	
23	D16	Data line	
24	D17	Data line	
25	D18	Data line	
26	D19	Data line	
27	GND	Ground	
28	D20	Data line	
29	D21	Data line	
30	D22	Data line	
31	D23	Data line	
32	GND	Ground	

Pin number	Name	RGB interface description	MCU interface description
33	PCLK / CMD DATA SEL	Pixel clock	Display RAM select. One address line of the MCU for displays where it is possible to select either register or data interface.
34	VSYNC / CS	Vertical Synchronization	Chip select
35	HSYNC / WE	Horizontal Synchronization	Write enable signal
36	DATA ENABLE / RE	Data enable signal	Read enable signal
37	SPI SCK	Clock for serial peripheral interface	
38	SPI MOSI	Master out slave in of serial peripheral interface	
39	SPI MISO	Master in slave out of serial peripheral interface	
40	SPI SS	Slave select for serial peripheral interface. Preferably a dedicated pin.	
41	ENABLE	Display enable	
42	I ² C SDA	I ² C data	
43	I ² C SCL	I ² C clock	
44	IRQ1	Interrupt 1	
45	IRQ2	Interrupt 2	
46	PWM	Backlight control	
47	RESET	Extension reset	
48	VCC	3.3V power supply for extension board	
49	VCC	3.3V power supply for extension board	
50	GND	Ground	

4. Hardware User Guide

4.1. Electrical Characteristics

maXTouch Xplained Pro can be connected to several Xplained Pro MCU boards and manually connected to other hardware. Xplained Pro MCU board(s) that does not have 3.3V as it's primary target voltage will read all ID devices on connected extensions to check if they support the target voltage before enabling it to the extension headers. The table below shows the static content written in the ID chip.

Table 4-1. maXTouch Xplained Pro ID Chip Content

Data field	Content
Product name	maXTouch Xplained Pro
Minimum operation voltage	3.0V
Maximum operation voltage	3.3V
Maximum current	50mA

Related Links

[Hardware Identification System](#) on page 7

4.2. Headers and Connectors

4.2.1. maXTouch Xplained Pro Extension Headers

maXTouch Xplained Pro implements one [Table 3-2 Xplained Pro Standard Extension Header](#) on page 8 marked with XPRO EXTENSION HEADER in silkscreen. This header makes it possible to connect the board to any Xplained Pro MCU board using a 20-pin ribbon cable (included in kit). maXTouch Xplained Pro also implements one [Table 3-3 Xplained Pro LCD Connector](#) on page 9 marked with XPRO LCD CONNECTOR in silkscreen. The pin-out definition for the extension header can be seen in [Table 4-2 maXTouch Xplained Pro Standard Extension Header](#) on page 11 and the pin-out for the LCD connector in [Table 4-3 maXTouch Xplained Pro Xplained Pro LCD Connector](#) on page 12.

Table 4-2. maXTouch Xplained Pro Standard Extension Header

Pin on EXT	Function	Description
1	ID	Communication line to ID chip
2	GND	Ground
3	Not Connected	
4	Not Connected	
5	GPIO	Command/Data Select
6	Not Connected	
7	PWM	Backlight control
8	Not Connected	
9	GPIO/IRQ	IRQ from maXTouch controller

Pin on EXT	Function	Description
10	GPIO	RESET signal for maXTouch and LCD controller
11	I ² C SDA	I ² C Data line for maXTouch controller
12	I ² C SCL	I ² C Clock line for maXTouch controller
13	Not Connected	
14	Not Connected	
15	CS	CS line for LCD controller
16	SPI MOSI	SPI Data to LCD controller
17	SPI MISO	SPI Data from LCD controller
18	SPI SCK	SPI Clock line
19	GND	Ground
20	VCC	Target supply voltage

Table 4-3. maXTouch Xplained Pro Xplained Pro LCD Connector

Pin number	Name	RGB interface description	MCU interface description
1	ID	Communication line to ID chip on extension board	
2	GND	Ground	
3	D0	Data line	
4	D1	Data line	
5	D2	Data line	
6	D3	Data line	
7	GND	Ground	
8	D4	Data line	
9	D5	Data line	
10	D6	Data line	
11	D7	Data line	
12	GND	Ground	
13	D8	Data line	
14	D9	Data line	
15	D10	Data line	
16	D11	Data line	
17	GND	Ground	
18	D12	Data line	
19	D12	Data line	

Pin number	Name	RGB interface description	MCU interface description
20	D14		Data line
21	D15		Data line
22	GND		Ground
23	D16		Data line
24	D17		Data line
25	Not Connected		
26	Not Connected		
27	GND		Ground
28	Not Connected		
29	Not Connected		
30	Not Connected		
31	Not Connected		
32	GND		Ground
33	PCLK / CMD_DATA_SEL	Pixel clock	Display RAM select. One address line of the MCU for displays where it is possible to select either the register or the data interface
34	VSYNC / CS	Vertical synchronization	Chip select
35	HSYNC / WE	Horizontal synchronization	Write enable signal
36	DATA ENABLE / RE	Data enable signal	Read enable signal
37	SPI SCK	Clock for Serial peripheral interface	
38	SPI MOSI	Master out slave in line of Serial peripheral interface	
39	SPI MISO	Master in slave out line of Serial peripheral interface	
40	SPI SS	Slave select for SPI. Should be unique if possible	
41	Not Connected		
42	TWI SDA	I ² C data line (maXTouch)	
43	TWI SCL	I ² C clock line (maXTouch)	
44	IRQ1	maXTouch interrupt line	
45	Not Connected		
46	PWM	Backlight control	
47	RESET	Reset for both display and maxTouch	
48	VCC	3.3V power supply for extension board	

Pin number	Name	RGB interface description	MCU interface description
49	VCC	3.3V power supply for extension board	
50	GND	Ground	

4.3. Peripherals

4.3.1. maXTouch Capacitive Touch Controller

maXTouch Xplained Pro has a ATMXT112S capacitive touch controller that's accessible over I²C. See code examples in ASF for how to set up and use the touch controller.

4.3.2. Interface Selector

maXTouch Xplained Pro features a 3-way DIP-switch that is used for configuring the display interface mode. Setting the switch positions to ON, will result in a high level (1) for the IMx line. See the table below for interface mode settings.

Table 4-4. maXTouch Xplained Pro DIP-Switch Settings

IM2	IM1	IM0	Interface	Pins in use
0	0	0	18-bit parallel bus	DB[17:0], CS, D/C, WE, RE
0	0	1	9-bit parallel bus	DB[8:0], CS, D/C, WE, RE
0	1	0	16-bit parallel bus	DB[15:0], CS, D/C, WE, RE
0	1	1	8-bit parallel bus	DB[7:0], CS, D/C, WE, RE
1	0	1	18-bit RGB parallel mode ⁽¹⁾	DB[17:0], HSYNC, VSYNC, PCLK, DE, MOSI, MISO, SCLK, CS
1	0	1	3-wire/9-bit SPI mode ⁽¹⁾	MOSI, MISO, SCLK, CS
1	1	1	4-wire/8-bit SPI mode	MOSI, MISO, SCLK, CS, D/C

Note:

1. The setting for RGB parallel mode and 3-wire SPI is the same. To be able to use the RGB mode, the internal configuration registers needs to be set correctly using 3-wire SPI.

4.4. Mounting

The kit includes accessories for mounting the display module to a MCU board.

- Mounting accessories:
 - Four M2.5 x 5 mm screws
 - Four M2.5 x 20 mm hex spacers (male to female)
 - Four M2.5 x 10 mm hex spacers (female to female)

4.4.1. Board Stacking Options

maXTouch Xplained Pro display module is intended to be mountable on top, on the bottom, or placed sideways to an Xplained Pro MCU board as shown in the following illustrations.

Figure 4-1. Side by Side Connection Option

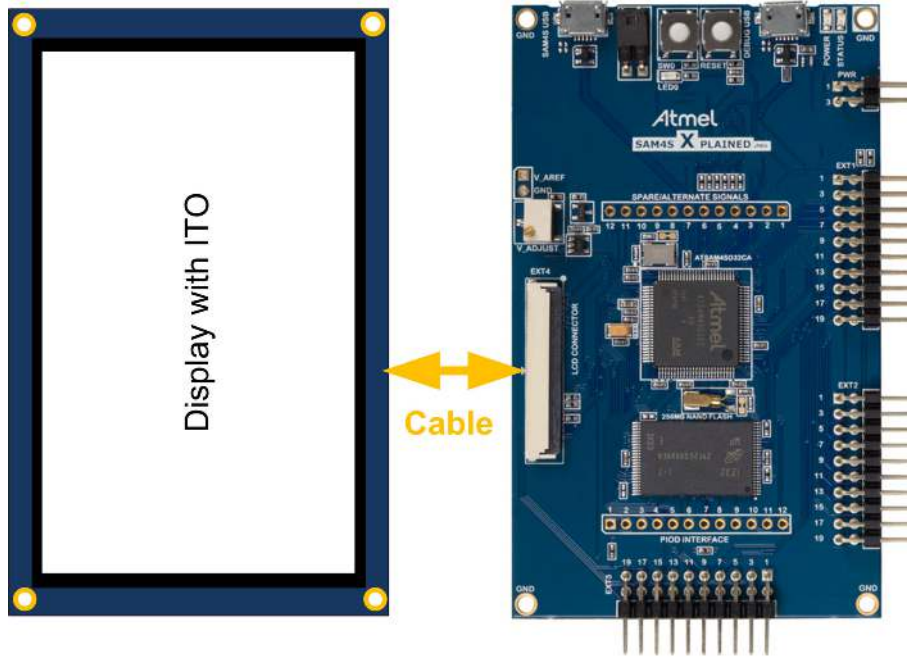

Figure 4-2. Top Side Mounting

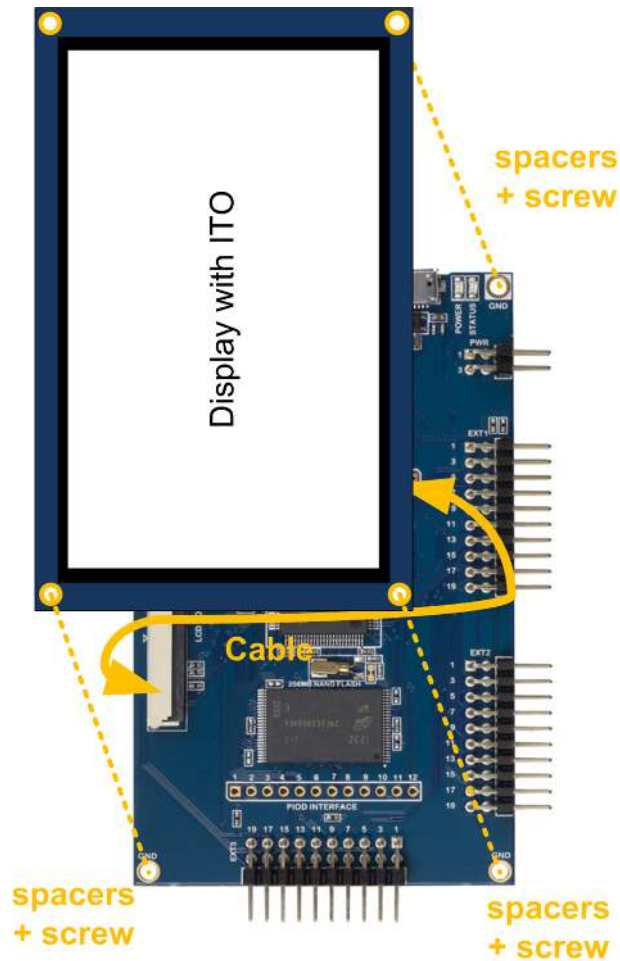
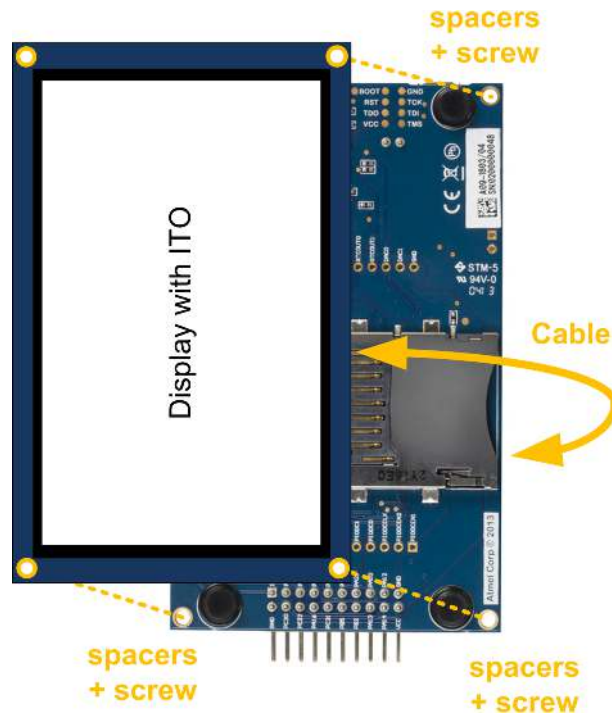

Figure 4-3. Bottom Side Mounting



The stacking is supported by spacers and screws. [Figure 4-4 Display Module Top-stacked](#) on page 16 shows an display module stacked on top of a MCU board. [Figure 4-5 Display Module Bottom-stacked](#) on page 17 shows an LCD board stacked on the bottom side of a MCU board, note that the MCU board has been flipped upside down in this drawing. Both of these mounting configurations requires four long spacers (M2.5 x 20mm, female/male), four short spacers (M2.5 x 10mm, female/female), and four screws (M2.5 x 5mm).

Figure 4-4. Display Module Top-stacked

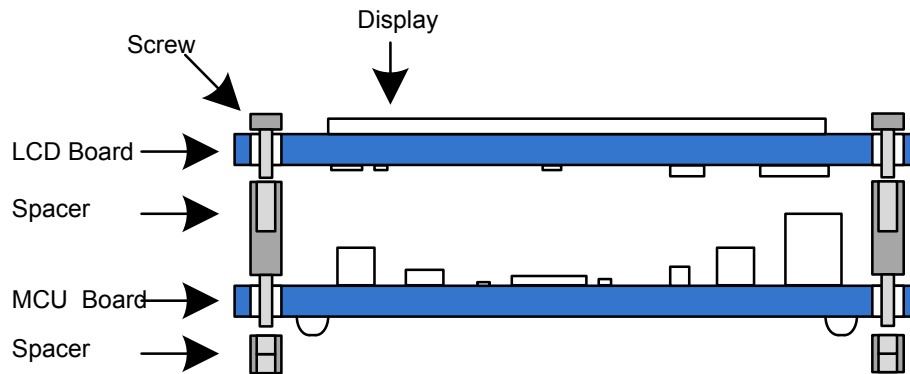
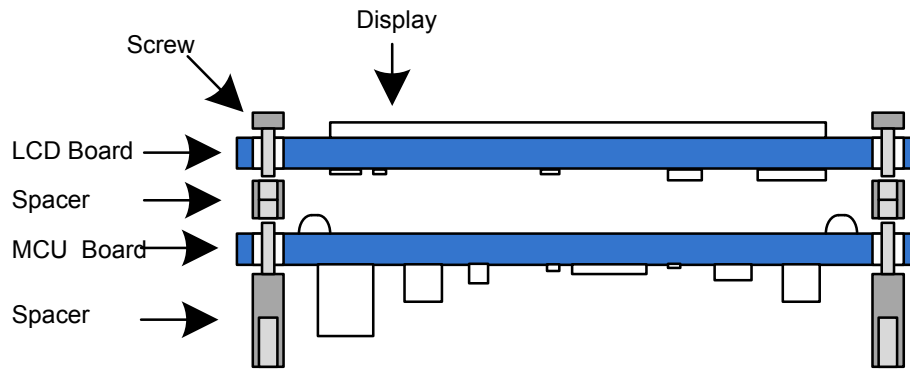

Figure 4-5. Display Module Bottom-stacked



5. Hardware Revision History and Known Issues

5.1. Identifying Product ID and Revision

The revision and product identifier of Xplained Pro boards can be found in two ways; either through Atmel Studio or by looking at the sticker on the bottom side of the PCB.

By connecting an Xplained Pro MCU board to a computer with Atmel Studio running, an information window will pop up. The first six digits of the serial number, which is listed under kit details, contain the product identifier and revision. Information about connected Xplained Pro extension boards will also appear in the Atmel Kit's window.

The same information can be found on the sticker on the bottom side of the PCB. Most kits will print the identifier and revision in plain text as A09-nnnn\rr, where nnnn is the identifier and rr is the revision. Boards with limited space have a sticker with only a QR-code, which contains a serial number string.

The serial number string has the following format:

```
"nnnnrrssssssss"  
n = product identifier  
r = revision  
s = serial number
```

The product identifier for maXTouch Xplained Pro is A09-2171.

5.2. Revision 2

Revision 2 of maXTouch Xplained Pro (2171) is the initial released version.

6. Document Revision History

Doc. rev.	Date	Comment
42350B	01/2016	Added Electrical Characteristics on page 11.
42350A	11/2014	Initial document release.

7. Evaluation Board/kit Important Notice

This evaluation board/kit is intended for use for **FURTHER ENGINEERING, DEVELOPMENT, DEMONSTRATION, OR EVALUATION PURPOSES ONLY**. It is not a finished product and may not (yet) comply with some or any technical or legal requirements that are applicable to finished products, including, without limitation, directives regarding electromagnetic compatibility, recycling (WEEE), FCC, CE or UL (except as may be otherwise noted on the board/kit). Atmel supplied this board/kit "AS IS," without any warranties, with all faults, at the buyer's and further users' sole risk. The user assumes all responsibility and liability for proper and safe handling of the goods. Further, the user indemnifies Atmel from all claims arising from the handling or use of the goods. Due to the open construction of the product, it is the user's responsibility to take any and all appropriate precautions with regard to electrostatic discharge and any other technical or legal concerns.

EXCEPT TO THE EXTENT OF THE INDEMNITY SET FORTH ABOVE, NEITHER USER NOR ATMEL SHALL BE LIABLE TO EACH OTHER FOR ANY INDIRECT, SPECIAL, INCIDENTAL, OR CONSEQUENTIAL DAMAGES.

No license is granted under any patent right or other intellectual property right of Atmel covering or relating to any machine, process, or combination in which such Atmel products or services might be or are used.

Mailing Address:

Atmel Corporation
1600 Technology Drive
San Jose, CA 95110
USA



Atmel Corporation 1600 Technology Drive, San Jose, CA 95110 USA T: (+1)(408) 441.0311 F: (+1)(408) 436.4200 | www.atmel.com

© 2016 Atmel Corporation. / Rev.: Atmel-42350B-maXTouch-Xplained-Pro_User Guide-01/2016

Atmel®, Atmel logo and combinations thereof, Enabling Unlimited Possibilities®, maXTouch®, and others are registered trademarks or trademarks of Atmel Corporation in U.S. and other countries. Windows® is a registered trademark of Microsoft Corporation in U.S. and or other countries. Other terms and product names may be trademarks of others.

DISCLAIMER: The information in this document is provided in connection with Atmel products. No license, express or implied, by estoppel or otherwise, to any intellectual property right is granted by this document or in connection with the sale of Atmel products. EXCEPT AS SET FORTH IN THE ATMEL TERMS AND CONDITIONS OF SALES LOCATED ON THE ATMEL WEBSITE, ATMEL ASSUMES NO LIABILITY WHATSOEVER AND DISCLAIMS ANY EXPRESS, IMPLIED OR STATUTORY WARRANTY RELATING TO ITS PRODUCTS INCLUDING, BUT NOT LIMITED TO, THE IMPLIED WARRANTY OF MERCHANTABILITY, FITNESS FOR A PARTICULAR PURPOSE, OR NON-INFRINGEMENT. IN NO EVENT SHALL ATMEL BE LIABLE FOR ANY DIRECT, INDIRECT, CONSEQUENTIAL, PUNITIVE, SPECIAL OR INCIDENTAL DAMAGES (INCLUDING, WITHOUT LIMITATION, DAMAGES FOR LOSS AND PROFITS, BUSINESS INTERRUPTION, OR LOSS OF INFORMATION) ARISING OUT OF THE USE OR INABILITY TO USE THIS DOCUMENT, EVEN IF ATMEL HAS BEEN ADVISED OF THE POSSIBILITY OF SUCH DAMAGES. Atmel makes no representations or warranties with respect to the accuracy or completeness of the contents of this document and reserves the right to make changes to specifications and products descriptions at any time without notice. Atmel does not make any commitment to update the information contained herein. Unless specifically provided otherwise, Atmel products are not suitable for, and shall not be used in, automotive applications. Atmel products are not intended, authorized, or warranted for use as components in applications intended to support or sustain life.

SAFETY-CRITICAL, MILITARY, AND AUTOMOTIVE APPLICATIONS DISCLAIMER: Atmel products are not designed for and will not be used in connection with any applications where the failure of such products would reasonably be expected to result in significant personal injury or death ("Safety-Critical Applications") without an Atmel officer's specific written consent. Safety-Critical Applications include, without limitation, life support devices and systems, equipment or systems for the operation of nuclear facilities and weapons systems. Atmel products are not designed nor intended for use in military or aerospace applications or environments unless specifically designated by Atmel as military-grade. Atmel products are not designed nor intended for use in automotive applications unless specifically designated by Atmel as automotive-grade.