

MATERIAL NUMBER	ENGINEERING NUMBER	FINISHED LENGTH
1300610143	104006A46M005	0.5M [1FT 8 IN]
1300610159	104006A46M100	10M [32FT 10 IN]
1300610163	104006A46M250	25M [82FT]

(A) PART NUMBER LEGEND

104006A45M005

LENGTH:
M005= 0.5 METER
M010= 1 METER
M100= 10 METER

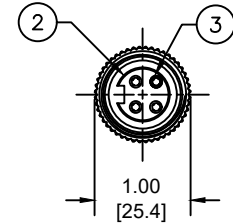
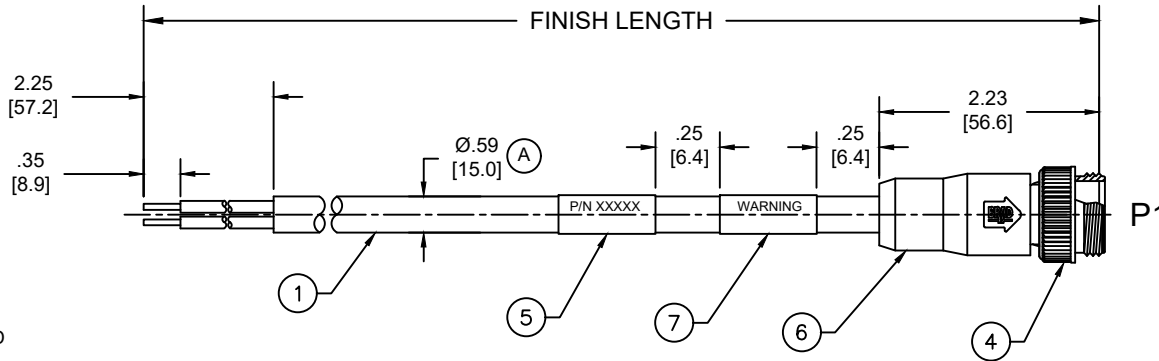
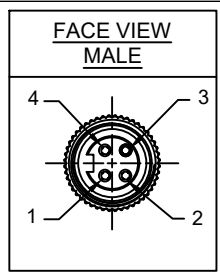
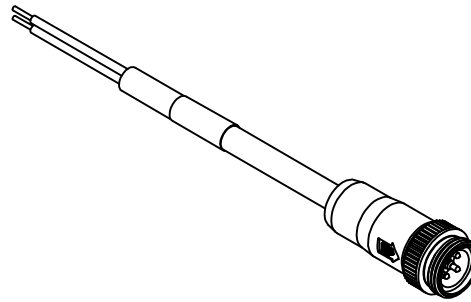

FACE VIEW - MALE

NOTES:

- MATERIAL: AS NOTED
- FINISH: AS NOTED
- ELECTRICAL:
 - VOLTAGE: 483V PER IEC60664 (A)
 - 600V PER UL2237
 - CURRENT: 15A
- TEMP RATING: -20°TO +105°C (A)
- PROTECTION: IP67 (WHEN MATED)
- COUPLING THREAD: 7/8"-16UN
- UL LISTED FILE: E258922
- ALL DIMENSIONS ARE FOR REFERENCE UNLESS TOLERANCED OR NOTED OTHERWISE

P1

BLACK	1
WHITE	2
RED	3
GREEN/YELLOW	4

WIRING DIAGRAM

(A)

CABLE LENGTH TOLERANCES	
<.3M [1FT]:	+19mm-0 [+ .75in-0]
.3 - .9M [1 - 3FT]:	+44.5mm-0 [+1.75in-0]
.9 - 1.8M [3 - 6FT]:	+55.6mm-0 [+2.19in-0]
1.8 - 3.7M [6 - 12FT]:	+88.9mm-0 [+3.50in-0]
3.7 - 7.3M [12 - 24FT]:	+165.1mm-0 [+6.50in-0]
7.3-14.6M [24 - 48FT]:	+317.5mm-0 [+12.50in-0]
14.6 - 30.5M [48-100FT]:	+622.3mm-0 [+24.50in-0]
OVER 30M [100FT]	+2% OF FINISHED LENGTH

ITEM	DESCRIPTION	MATERIAL	FINISH
7	WARNING LABEL	VINYL	BLACK
6	OVERMOLD	TPE	GRAY
5	WRAP LABEL	VINYL	YELLOW
4	COUPLING NUT	ZINC ALLOY	BLACK E-COAT
3	PIN CONTACT	BRASS	GOLD OVER NICKEL
2	INSERT	TPE	BLACK
1	#14/4 CABLE	PVC JACKET	GRAY

FUNCTIONAL SYMBOLS $F_A=0$ $F_C=0$ $F_P=0$	THIS DRAWING CONTAINS INFORMATION THAT IS PROPRIETARY TO MOLEX ELECTRONIC TECHNOLOGIES, LLC AND SHOULD NOT BE USED WITHOUT WRITTEN PERMISSION		CURRENT REV DESC: ITEM 2 & 6 WERE PVC. ADDED IEC VOLTAGE, PN MATRIX, CABLE DIA & TOL CHART. MODIFIED TEMP RATING AND PN TABLE.		<p>BRAD POWER CORDSET, A-SIZE 4-POLE, MALE, STRAIGHT, SINGLE KEY, #14 AWG</p> <p>PRODUCT CUSTOMER DRAWING</p>																
	DIMENSION UNITS INCH/MM	SCALE NTS	EC NO: 698916 DRWN: ABENJAMINLW 2021/06/17 CHK'D: RSTONE 2022/03/09 APPR: BWOODMAN 2022/03/11																		
	GENERAL TOLERANCES (UNLESS SPECIFIED)		INITIAL REVISION: DRWN: VOU 2010/01/14 APPR: JFMURPHY 2010/01/20																		
	<table border="1"> <thead> <tr> <th></th> <th>mm</th> <th>INCH</th> </tr> </thead> <tbody> <tr> <td>4 PLACES</td> <td>±----</td> <td>±----</td> </tr> <tr> <td>3 PLACES</td> <td>±----</td> <td>±----</td> </tr> <tr> <td>2 PLACES</td> <td>±----</td> <td>±----</td> </tr> <tr> <td>1 PLACE</td> <td>±----</td> <td>±----</td> </tr> <tr> <td>0 PLACES</td> <td>±----</td> <td>±----</td> </tr> </tbody> </table>			mm		INCH	4 PLACES	±----	±----	3 PLACES	±----	±----	2 PLACES	±----	±----	1 PLACE	±----	±----	0 PLACES	±----	±----
	mm	INCH																			
4 PLACES	±----	±----																			
3 PLACES	±----	±----																			
2 PLACES	±----	±----																			
1 PLACE	±----	±----																			
0 PLACES	±----	±----																			
DIVISIONAL SYMBOLS		ANGULAR TOL ± ---- °	DRAFT WHERE APPLICABLE MUST REMAIN WITHIN DIMENSIONS	THIRD ANGLE PROJECTION	DRAWING: A-SIZE	SERIES: 130061	MATERIAL NUMBER: SEE CHART	CUSTOMER: GENERAL MARKET	SHEET NUMBER: 1 OF 1												

DOCUMENT STATUS	P1	RELEASE DATE	2022/03/11	14:29:47
-----------------	----	--------------	------------	----------