



## Finger Print Unit (FPC1020A)

SKU: U008

**FINGER** Unit is a fingerprint sensor. This all-in-one fingerprint sensor makes fingerprint adding, verification, managing super simple.

Uart protocol, Compact size and ultra-low power consumption makes it very attractive to use around M5Stack series product. it performs fast fingerprint matching with highest security level and optimal user convenience. You can program to set the fingerprint recognition comparison level and different security level . if you ever consider secure your project with biometrics, don't forget to include this M5unit **FINGER**.

**This unit communicate with M5Core by UART protocol connected via PORTC**

UART settings:

- Baudrate(**default: 19200bps**)
- Start bits(1 bit)
- Stop bits(1 bit)
- Parity(no)

# Product Features

- Fingerprint capacity: 1000/1700/2000/3000(Default:1700)
- False Acceptance Rate: <0.001%(Security level 3)
- False Rejection Rate: <0.1%(Security level 3)
- Security Level: 1-5 (Default: 3)
- Output Format: User name, finger image, feature value
- Characteristics value size: 193 Byte
- Communication Interface: UART
- Response Time: Fingerprint processing < 0.45
- Communication Baudrate: 9600-115200 (default: 19200)
- Operating Temperature: -10C - 60C
- Operating Humidity: 20%-80%

---

Parameter	Value
Fingerprint capacity	1000/1700/2000/3000 ( Default: 1700 )
False Acceptance Rate	<0.001% ( Security Level: 3 )
False Rejection Rate	<0.1% ( Security Level: 3 )
Comparison mode	1: 1 verification / 1: N Identification
Security Level	1 - 5 ( Default: 3 )
Quiescent Current	< 20 uA
Response time	Fingerprint preprocessing < 0.45s
Output format	User name, finger image, feature value
Characteristic value size	193 Byte
Communication Interface	UART
Communication Baudrate	9600-115200 ( Default: 19200 )
Operating temperature	-10° - 60°
Operation humidity	20% - 80%

## Kit includes

- 1x FINGER Unit
- 1x Grove Cable

## Application

- Fingerprint Attendance Machine
- Fingerprint Locker

# Example

## Arduino IDE

The code below is incomplete(just for usage). To get the complete code, please click [here](#).

```
/*  
  Connect to GRVOE C on M5Core  
*/  
#include <M5Stack.h>  
#include "finger.h"  
  
uint8_t userNum; //User number  
uint8_t res1;  
  
// result for "res1"  
#define ACK_SUCCESS    0x00  
#define ACK_FAIL      0x01  
#define ACK_FULL      0x04  
#define ACK_NOUSER    0x05  
#define ACK_USER_EXIST 0x07  
#define ACK_TIMEOUT   0x08  
  
// initialization  
M5.begin();  
Serial2.begin(19200, SERIAL_8N1, 16, 17);  
userNum = fpm_getUserNum();  
M5.Lcd.print("userNum:");  
M5.Lcd.println(userNum);  
  
// add a new user  
res1 = fpm_addUser(userNum,1); //get function result  
  
// compare your finger  
res1 = fpm_compareFinger();  
  
// delete all user  
res1 = fpm_deleteAllUser();
```



# Schematic

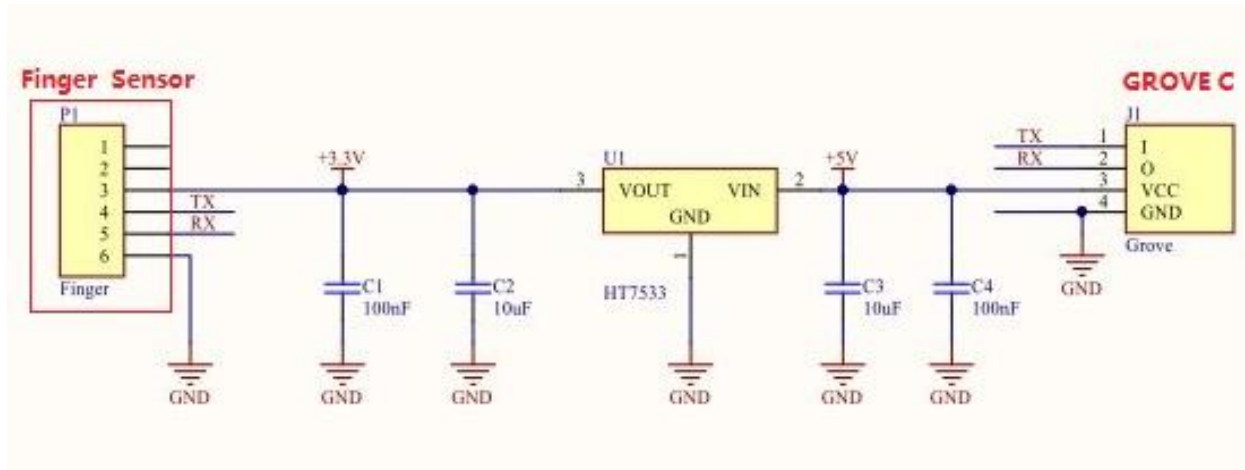

# PinMap

M5Core(GROVE C)	U2RXD	U2TXD	5V	GND
FINGER Unit	TXD	RXD	5V	GND





<https://m5stack.com/products/finger-sensor-unit/12-6-19>