



Sep. 2018 Ver.6.0
TDK Corporation

Multilayer Low Pass Filter

For 1880-2025MHz

DEA Series 1.6x0.8mm [EIA 0603] TYPE

P/N: **DEA162025LT-5046E1**

DEA162025LT-5046E1

■ SHAPES AND DIMENSIONS

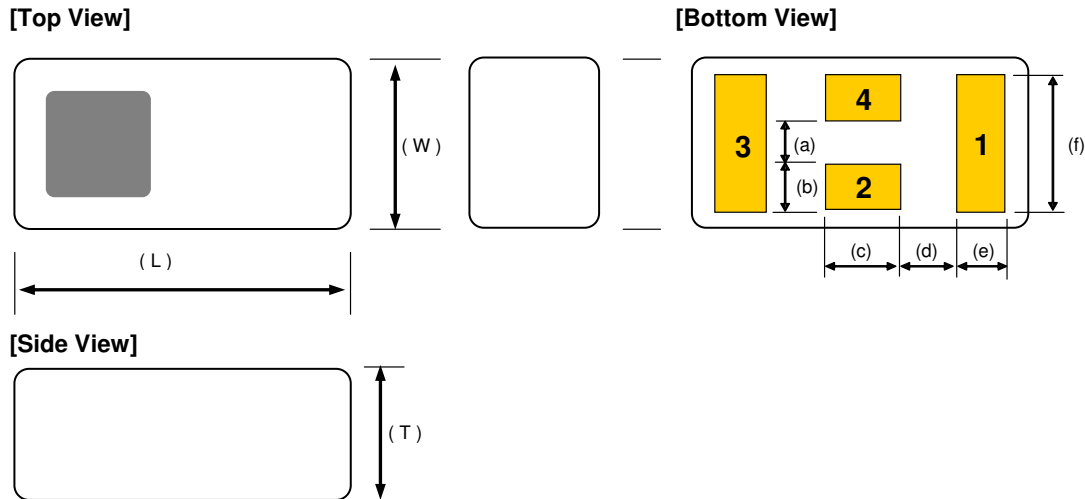

Dimensions (mm)

L	W	T	a	b	c	d	e	f
1.60	0.80	0.60	0.21	0.22	0.40	0.30	0.225	0.65
+/-0.10	+/-0.10	+/-0.10	+/-0.05	+/-0.05	+/-0.05	+/-0.05	+/-0.05	+/-0.05

Terminal functions

(1)	Input / Output Port
(2)	GND

(3)	Output / Input Port
(4)	GND

■ TERMINATION FINISH

Material
Au plate

DEA162025LT-5046E1**ELECTRICAL CHARACTERISTICS**

(Measurement)

Parameter	Frequency (MHz)	TDK Spec		
		Min.	Typ.	Max.
Insertion Loss (dB)	1880 to 1920	-	0.43	0.60
	1920 to 1980	-	0.52	0.70
	2010 to 2025	-	0.61	0.80
Insertion Loss (dB) (-40 to +85 °C)	1880 to 1920	-	-	0.75
	1920 to 1980	-	-	0.90
	2010 to 2025	-	-	1.00
VSWR	1880 to 2025	-	1.1	2.0
Attenuation (dB)	2400 to 2500	15	21	-
	5150 to 5850	12	15	-
	3760 to 4050	20	26	-
	5640 to 6075	12	14	-
	7520 to 8100	5	7	-
Power Handling (dBm)		-	-	30
Characteristic Impedance (ohm)		50 (Nominal)		

Ta = +25+/-5°C

MAXIMUM RATINGS

Parameter	TDK Spec		Conditions
	Min.	Max.	
Operating temperature (°C)	-40 to +85 °C		
Storage temperature (°C)	-40 to +85 °C		
Human Body Model : HBM @Each Port (V)	-1000	1000	100pF / 1500ohm
Machine Model : MM @Each Port (V)	-150	150	200pF / 0ohm
Charged Device Model : CDM @Each Port (V)	-500	500	Relative humidity : 60%RH max

Ambient temperature : +25+/-5°C

DEA162025LT-5046E1

FREQUENCY CHARACTERISTICS

S11 POLA REF 1.0 U SCALE 1.0U FS

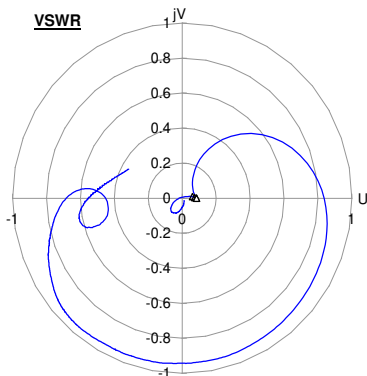

MARKER 1	1880 MHz	-1.13
MARKER 2	1920 MHz	-1.16
MARKER 3	1980 MHz	-1.18
MARKER 4	2025 MHz	-1.19

S21 Log MAG REF 0.0dB SCALE 5dB/

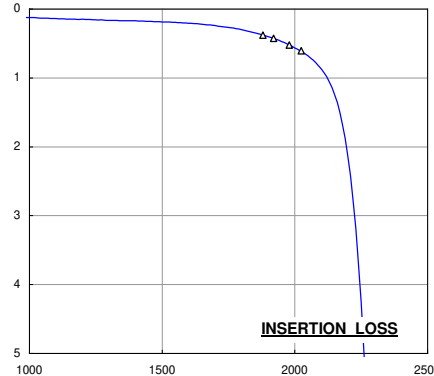

MARKER 1	1880 MHz	0.38 dB
MARKER 2	1920 MHz	0.43 dB
MARKER 3	1980 MHz	0.52 dB
MARKER 4	2025 MHz	0.61 dB

S21 Log MAG REF 0.0dB SCALE 5.0dB/

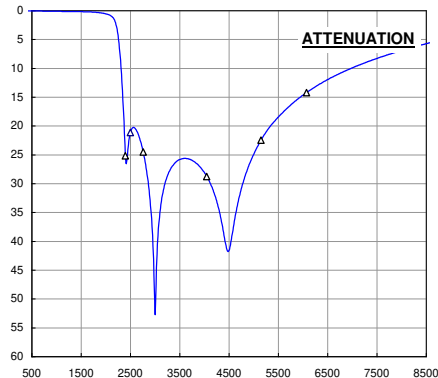

MARKER 1	2400 MHz	25.2 dB
MARKER 2	2500 MHz	21.2 dB
MARKER 3	2760 MHz	24.5 dB
MARKER 4	4050 MHz	28.8 dB
MARKER 5	5150 MHz	22.5 dB
MARKER 6	6075 MHz	14.2 dB

S11 Log MAG REF -10.0dB SCALE 5.0dB/

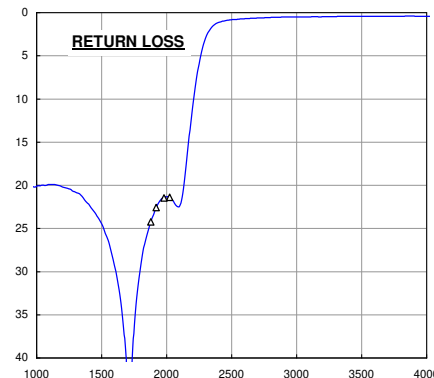

MARKER 1	1880 MHz	24.2 dB
MARKER 2	1920 MHz	22.6 dB
MARKER 3	1980 MHz	21.5 dB
MARKER 4	2025 MHz	21.4 dB

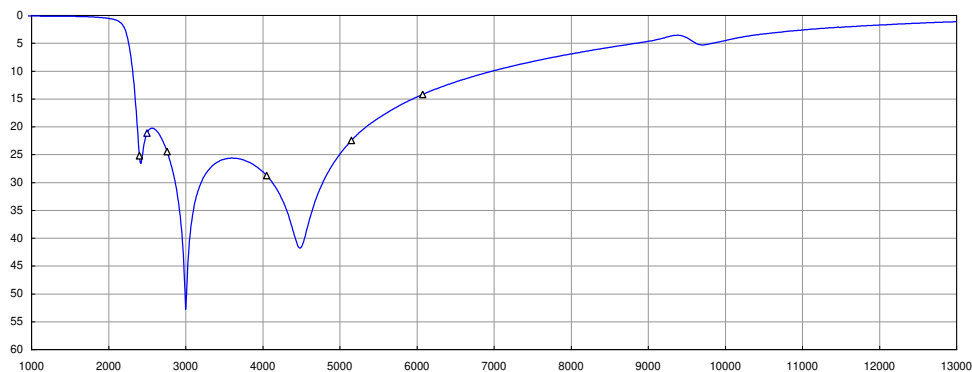

MARKER 1	2400 MHz	25.2 dB
MARKER 2	2500 MHz	21.2 dB
MARKER 3	2760 MHz	24.5 dB
MARKER 4	4050 MHz	28.8 dB
MARKER 5	5150 MHz	22.5 dB
MARKER 6	6075 MHz	14.2 dB

DEA162025LT-5046E1

RECOMMENDED LAND PATTERN

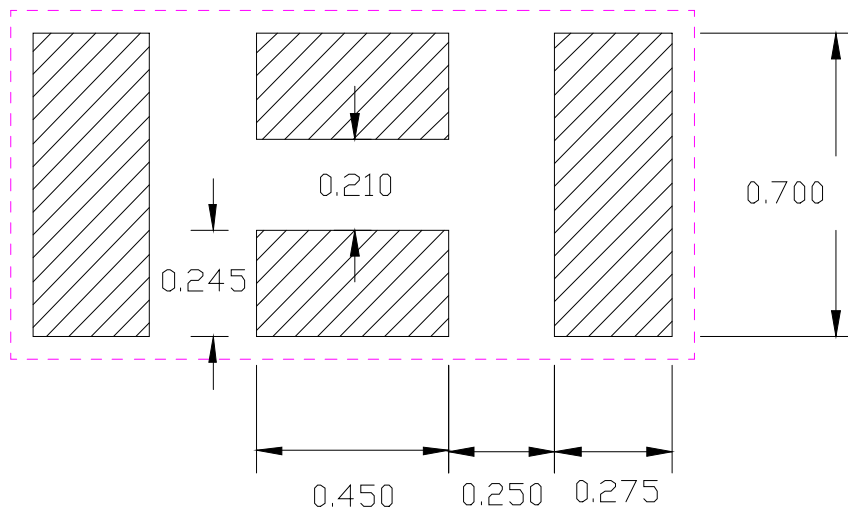

EVALUATION BOARD

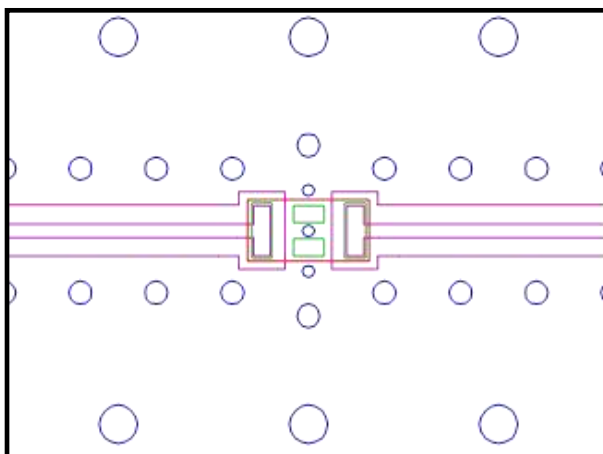

- Thru hole
- Resist
- Surface Pattern
- DUT (LPF)

Material, Layer	Thickness
Top Resist	Resist
Copper Surface Pattern	0.035mm
FR-4	0.10mm
Copper Inner GND	0.018mm
FR-4	0.30mm
Copper Bottom GND	0.035mm

* Line width should be designed to match 50 ohm characteristic impedance depending on PCB material and thickness.

ENVIRONMENT INFORMATION

RoHS Statement
 RoHS Compliance

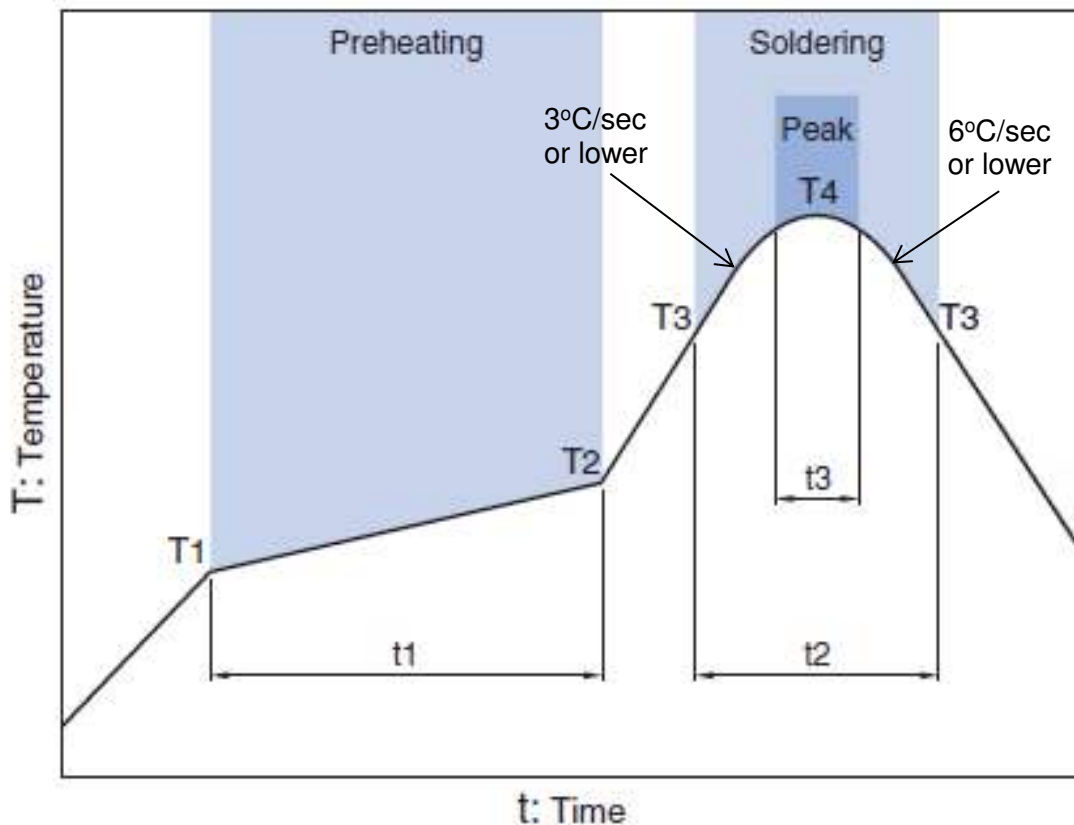
DEA162025LT-5046E1**RECOMMENDED REFLOW PROFILE**

Preheating			Soldering			
			Critical zone (T3 to T4)		Peak	
Temp.		Time	Temp.	Time	Temp.	Time
T1	T2	t1	T3	t2	T4	t3 *
150°C	200°C	60 to 120sec	217°C	60 to 120sec	240 to 260°C	30 sec Max

* t3 : Time within 5°C of actual peak temperature

The maximum number of reflow is 3.

Note: Lead free solder is recommended.
Recommended solder is Sn-3.0Ag-0.5Cu. (M705 by Senju Metal Industry)

DEA162025LT-5046E1

■ PACKAGING STYLE

Reel Dimensions

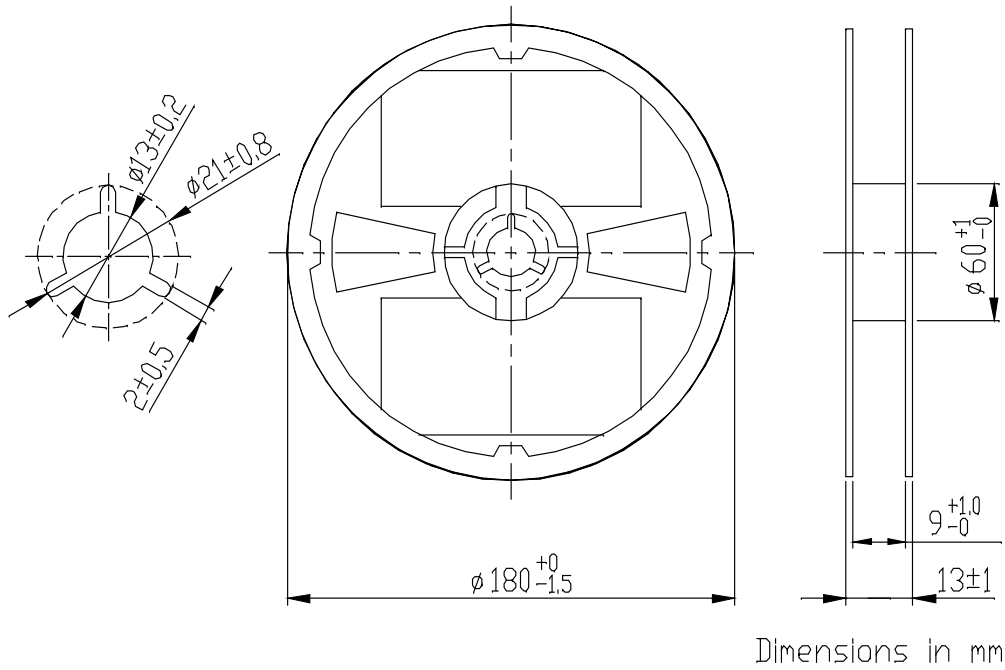

Dimensions in mm

STANDARD PACKAGE QUANTITY (pieces/reel)
4,000

DEA162025LT-5046E1

■ PACKAGING STYLE

Carrier tape 1 , Material : paper

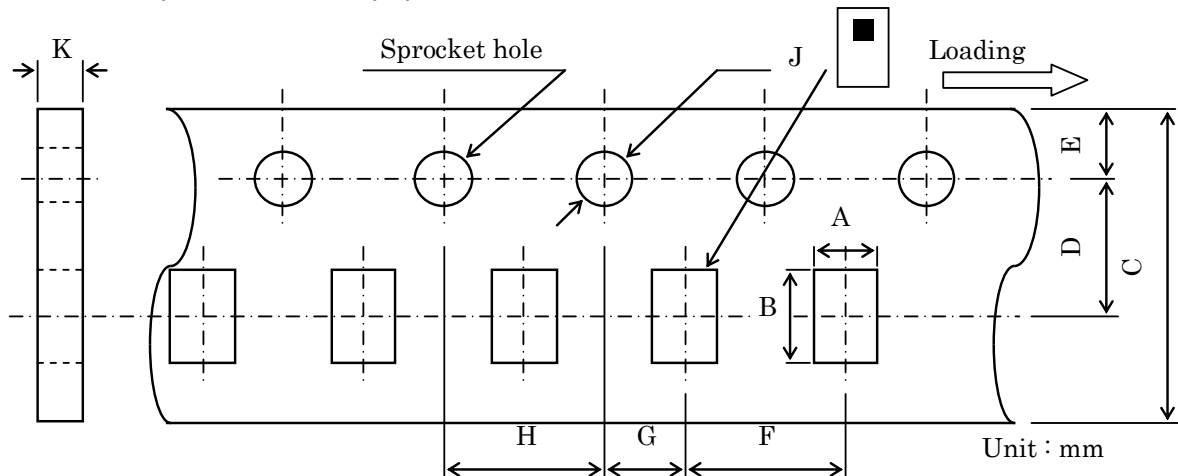

Dimensions (mm)

A	B	C	D	E	F	G	H	J	K
0.95	1.8	8.0	3.5	1.75	4.0	2.0	4.0	1.5	0.80
+/-0.05	+/-0.05	+/-0.2	+/-0.05	+/-0.1	+/-0.1	+/-0.05	+/-0.1	+0.1/-0	MAX

Carrier tape 2 , Material : PS

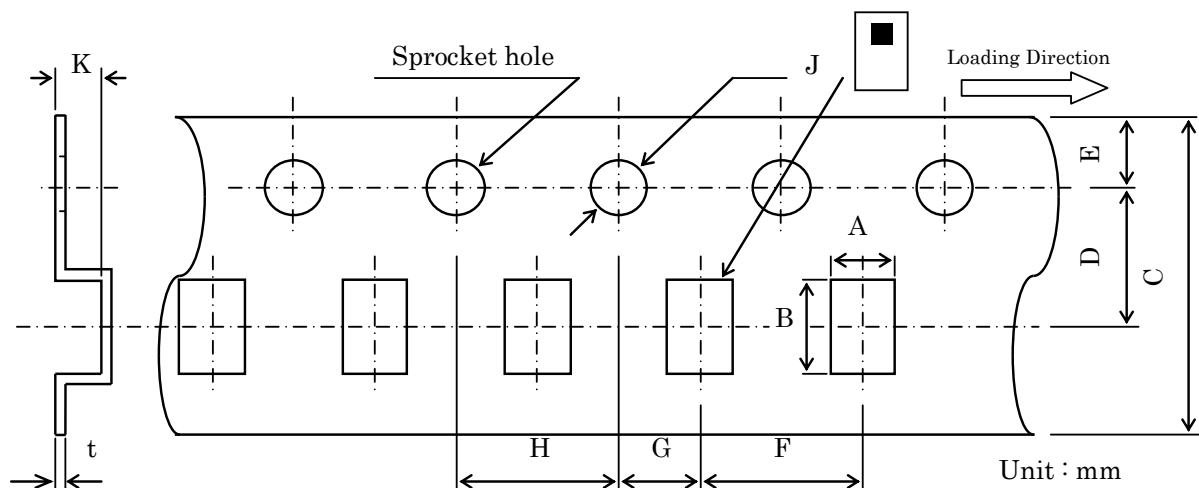

Dimensions (mm)

A	B	C	D	E	F	G	H	J	K	t
0.97	1.8	8.0	3.5	1.75	4.0	2.0	4.0	1.5	0.80	0.25
+/-0.05	+/-0.05	+/-0.2	+/-0.05	+/-0.1	+/-0.1	+/-0.05	+/-0.1	+0.1/-0	MAX	+/-0.05

"Carrier tape 1" is currently adopted. "Carrier tape 2" will be running change after Feb.2016.

REMINDERS FOR USING THESE PRODUCTS

Before using these products, be sure to request the delivery specifications.

SAFETY REMINDERS

Please pay sufficient attention to the warnings for safe designing when using these products.

REMINDERS

The products listed on this catalog are intended for use in general electronic equipment (AV equipment, telecommunications equipment, home appliances, amusement equipment, computer equipment, personal equipment, office equipment, measurement equipment, industrial robots) under a normal operation and use condition.

The products are not designed or warranted to meet the requirements of the applications listed below, whose performance and/or quality require a more stringent level of safety or reliability, or whose failure, malfunction or trouble could cause serious damage to society, person or property.

Please understand that we are not responsible for any damage or liability caused by use of the products in any of the applications below or for any other use exceeding the range or conditions set forth in this catalog.

- | | |
|---|--|
| (1) Aerospace/Aviation equipment | (8) Public information-processing equipment |
| (2) Transportation equipment (cars, electric trains, ships, etc.) | (9) Military equipment |
| (3) Medical equipment | (10) Electric heating apparatus, burning equipment |
| (4) Power-generation control equipment | (11) Disaster prevention/crime prevention equipment |
| (5) Atomic energy-related equipment | (12) Safety equipment |
| (6) Seabed equipment | (13) Other applications that are not considered general-purpose applications |
| (7) Transportation control equipment | |

When using this product in general-purpose applications, you are kindly requested to take into consideration securing protection circuit/equipment or providing backup circuits, etc., to ensure higher safety.