

ASMT-FG70-NFJ00

Surface Mount Auto Focus Auxiliary LED

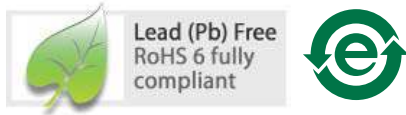

Data Sheet



Description

ASMT-FG70 is a SMT (Surface Mount Technology) dome LED lamp that employs an untinted, non diffused lens to provide high luminous intensity with a narrow radiation pattern. By having PCB as its substrate, this package offers smaller footprint and dome size that allow compact end application design.

This lamp type LED utilizes Indium Gallium Nitrate (InGaN) material technology. The InGaN material has a very high luminous efficiency, capable of producing high light output over a wide range of drive currents.

The narrow angle package is designed for applications that require long distance illumination with a narrow beam pattern such as auxiliary flash for auto-focus functions in digital still cameras etc.

This environmental friendly, green SMT Lamp is shipped in tape and reel packaging in order to facilitate pick and place operation.

Features

- Smooth, consistent narrow radiation pattern
- 14 degree viewing angle
- 3.2 x 3.6 x 3.4 mm package dimensions
- Clear, non diffused epoxy

Application

- Camera

Package Drawing

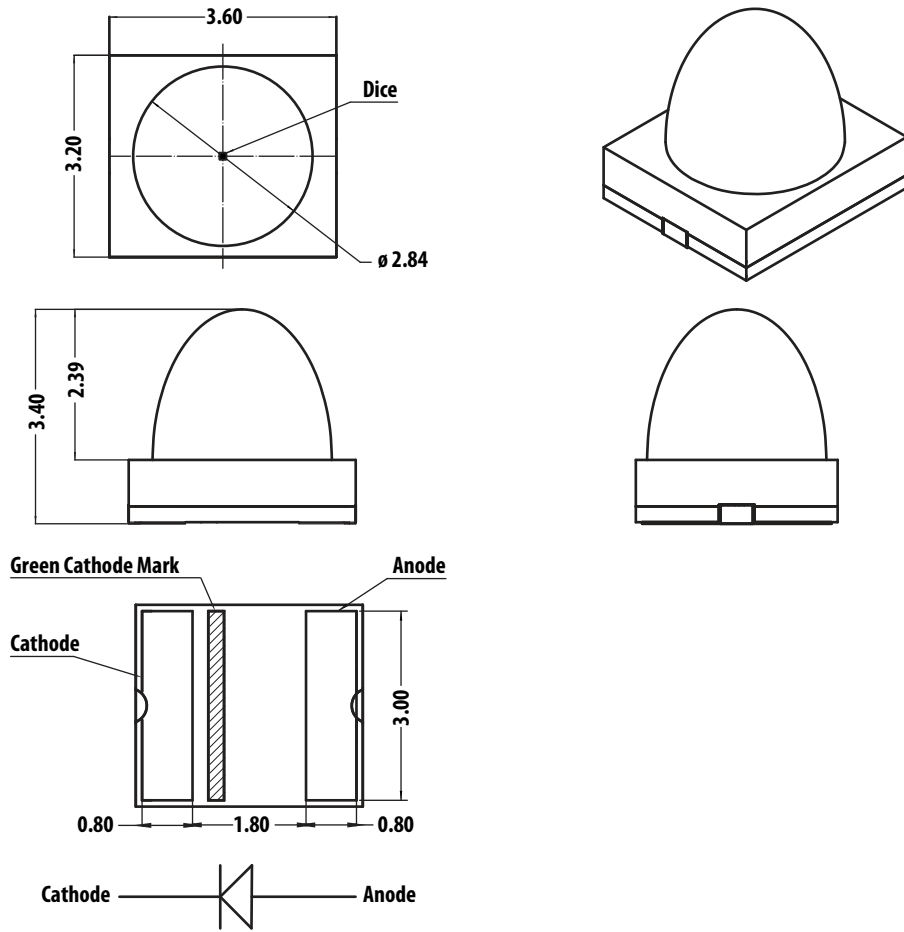

1. Unit: millimeters.
2. Tolerance ± 0.1 mm unless otherwise specified.

Device Selection Guide

Part Number	Color	Dice
ASMT-FG70-NFJ00	Green	InGaN

CAUTION: LED is ESD sensitive. Please observe appropriate precautions during handling and processing.

Absolute Maximum Ratings (T_A = 25° C)

Parameter	Rating	Unit
DC Forward Current	30	mA
Power Dissipation	117	mW
Operating Temperature	-40 to 85	°C
Storage Temperature	-40 to 85	°C
Moisture Sensitivity Level (IPC/JEDEC J-STD-020)	3	–

Optical/Electrical Characteristics (T_A = 25° C)

Parameter	Test condition	Min	Typ	Max	Unit
Luminous intensity (I _v)	I _F = 20 mA	15.0	22.0	56.0	cd
Peak wavelength (λ _p)	I _F = 20 mA		519		nm
Dominant wavelength (λ _d)	I _F = 20 mA	515		535	nm
Viewing angle (2θ _{1/2})	I _F = 20 mA		14		Degree
Forward voltage (V _F) ¹	I _F = 20 mA		3.1	3.9	V
Reverse voltage (V _R)	I _R = 10 μA	5			V

Note:

1. Tolerance ±0.1 V

Luminous Intensity Bin

Bin	Min (cd)	Max (cd)
F	15.0	19.5
G	19.5	25.5
H	25.5	33.0
I	33.0	43.0
J	43.0	56.0

Tolerance ±15%

Color Bin

Bin	Min (nm)	Max (nm)
A	515	520
B	520	525
C	525	530
D	530	535

Tolerance ±1 nm

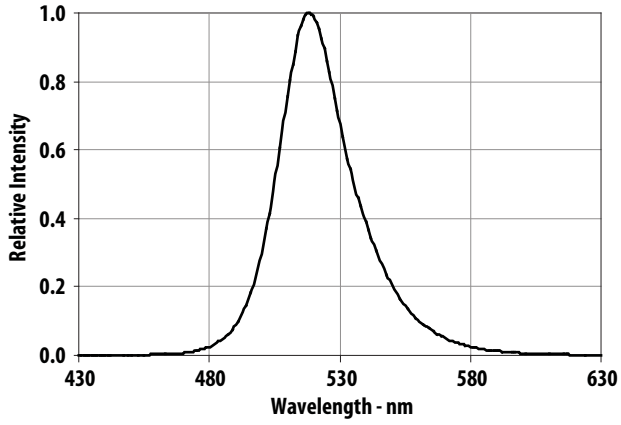

Relative Intensity vs. Wavelength

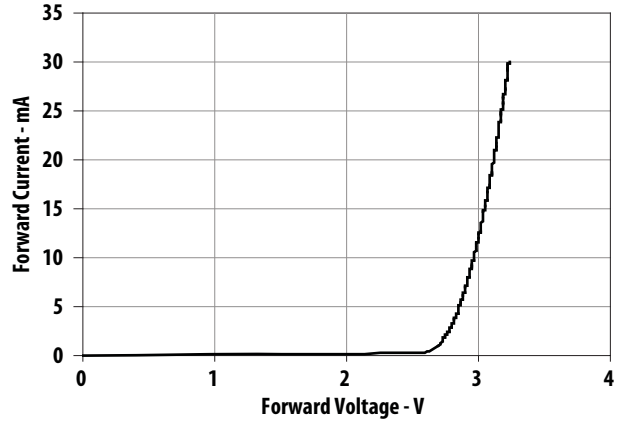

Forward Current vs Forward Voltage

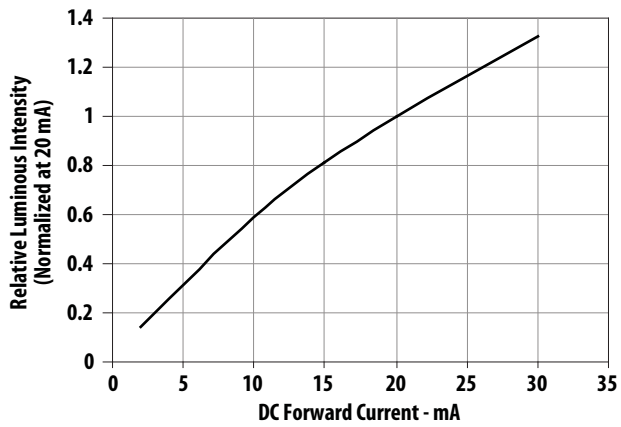

Relative Intensity vs Forward Current

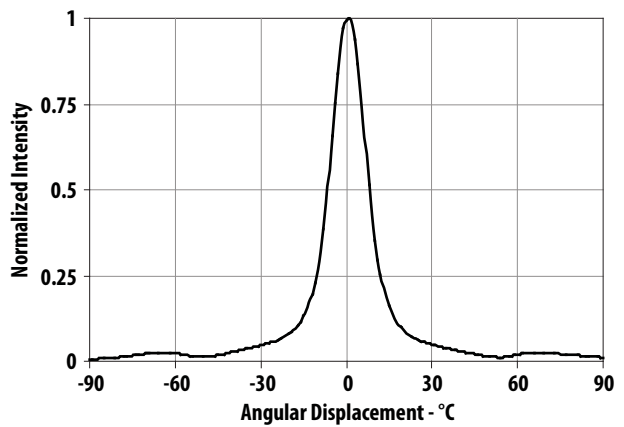

Radiation Pattern

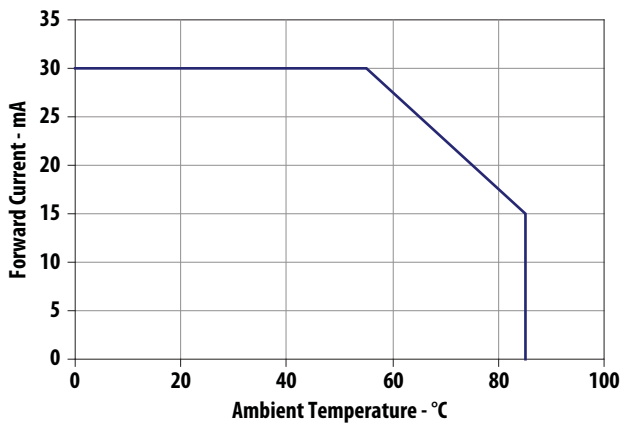

Maximum Forward Current vs Ambient Temperature

Recommended Reflow Soldering Profile

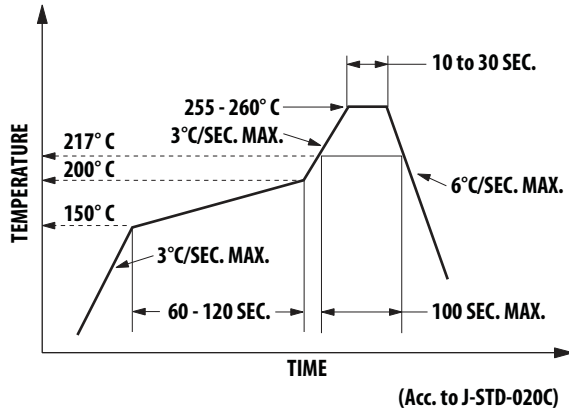

Recommended Soldering Land Pattern

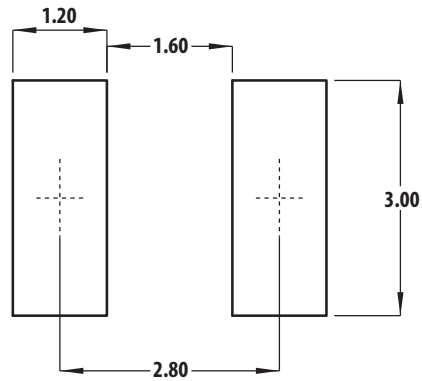

Unit: mm

Tape Dimensions

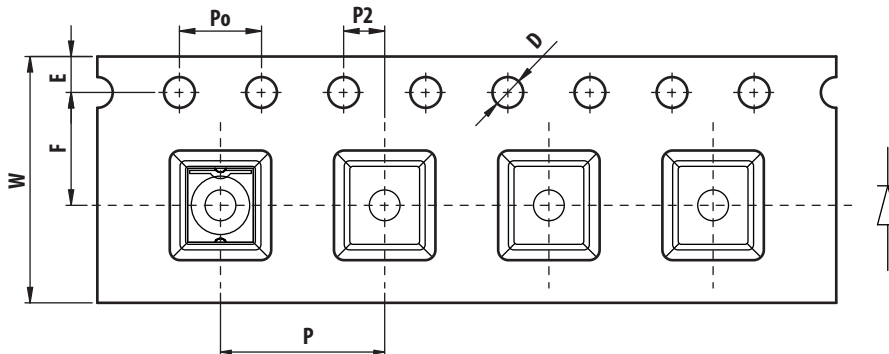

W	12.00	± 0.30
P	8.00	± 0.10
E	1.75	± 0.10
F	5.50	± 0.10
P2	2.00	± 0.10
D	1.50	+0.10 -0.00
P0	4.00	± 0.10

1. Unit: millimeters.
2. Tolerance ± 0.1 mm unless otherwise specified.

Tape leader and trailer

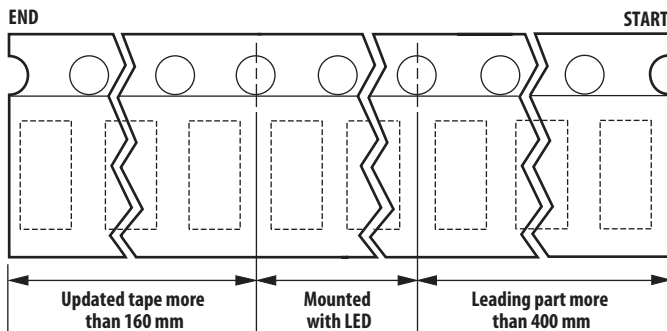

For product information and a complete list of distributors, please go to our web site: www.avagotech.com

Avago, Avago Technologies, and the A logo are trademarks of Avago Technologies in the United States and other countries. Data subject to change. Copyright © 2005-2011 Avago Technologies. All rights reserved. AV02-3228EN - January 6, 2012

Avago
TECHNOLOGIES