

IsoLoop[®] Isolated PROFIBUS Evaluation Board

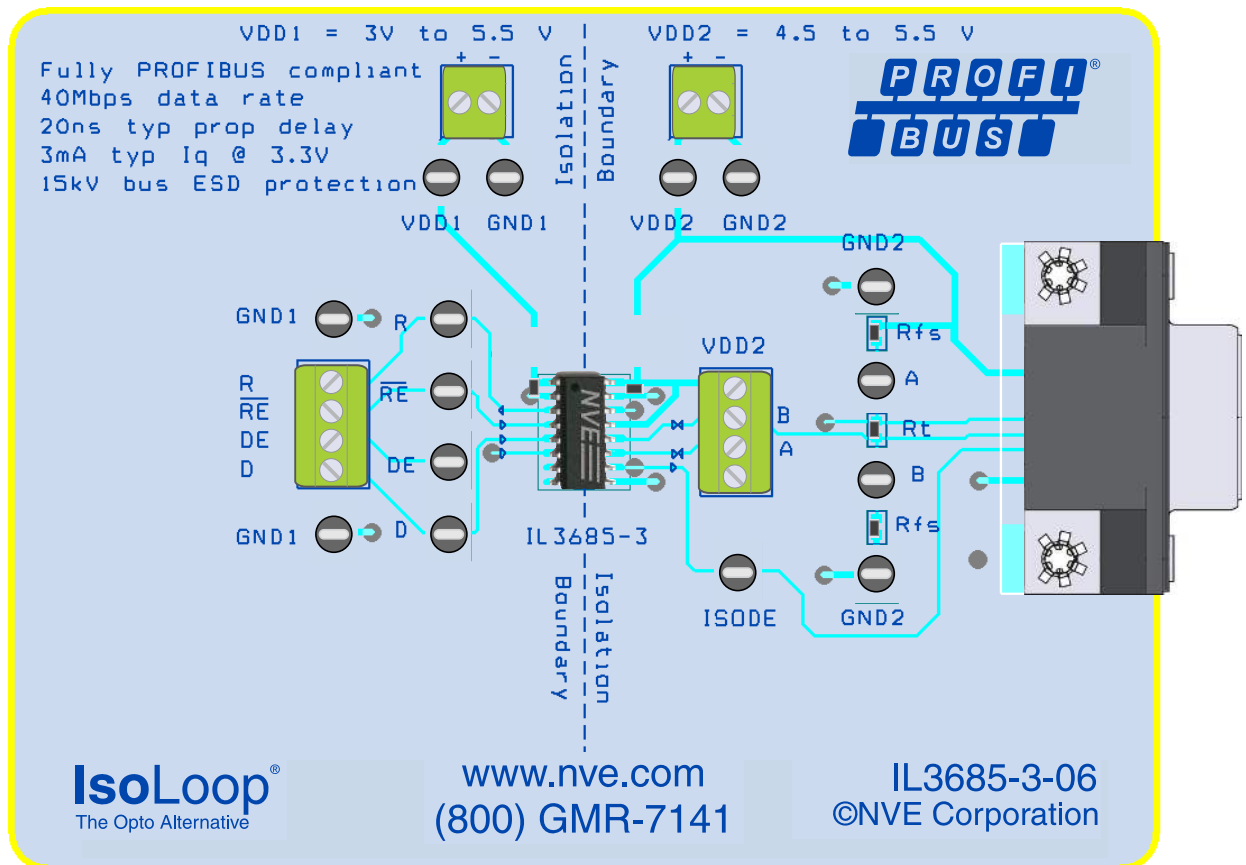

Board No.: IL3685-3-01

About This Evaluation Board

Isolation reduces noise, eliminates ground loops, and improves safety.

This Evaluation Board provides a complete isolated PROFIBUS node using the ultraminiature IL3685-3E narrow-body isolated transceiver.

The evaluation board provides screw terminal and DB9 connections, and demonstrates best layout practices including separate ground planes. Termination, pull-up, and pull-down resistors can be changed to accommodate different configurations.

The IL3685 is a galvanically isolated transceiver using NVE's patented IsoLoop spintronic Giant Magnetoresistance (GMR) technology.

Full PROFIBUS compliance includes the rigorous PROFIBUS differential output voltage specifications. Current limiting and thermal shutdown features protect against output short circuits and bus contention that may cause excessive power dissipation. Receiver inputs feature a "fail-safe if open" design, ensuring a logic high R-output if A/B are floating.

IL3685 Specification Highlights

- 40 Mbps data rate
- 3 V to 5.5 V power supplies
- 20 ns propagation delay
- 5 ns pulse skew
- 100 ps jitter
- Low quiescent supply current
- 2.5 kV_{RMS} and 6 kV_{RMS} isolation versions
- Low EMC footprint
- Thermal shutdown protection
- -40°C to +85°C temperature range
- Meets or exceeds ANSI RS-485 and ISO 8482:1987(E)
- PROFIBUS compliant
- VDE V 0884 certified and UL 1577 recognized
- Available in 16-pin wide-body, narrow-body and QSOP packages

Visit www.IsoLoop.com for datasheets and illustrative applications.

Evaluation Board Layout

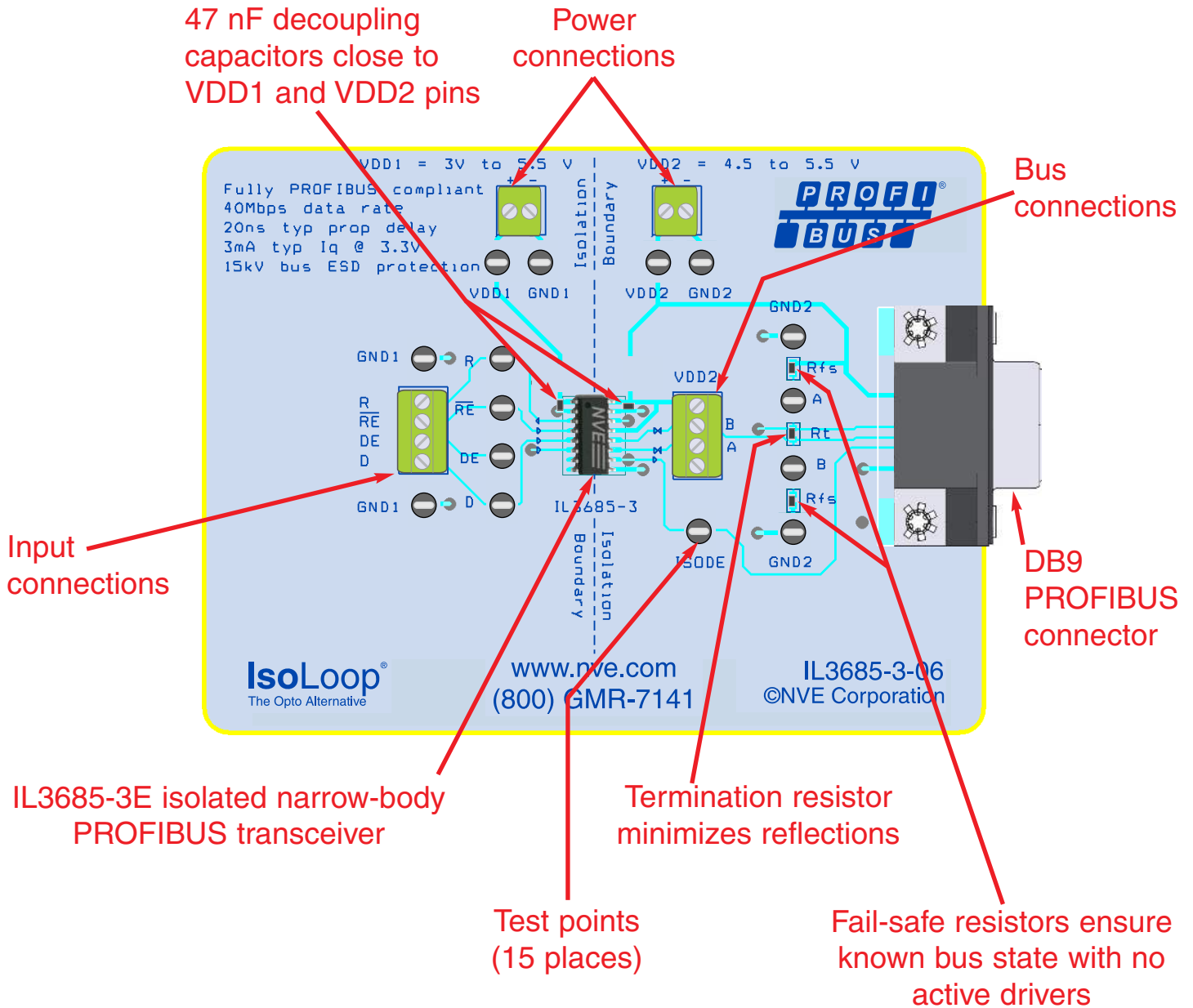

Quick Start

- Connect V_{DD1} to a 3.3 V power supply and V_{DD2} to a 5 V supply.
- Tie “DE” high and “ \overline{RE} ” low to enable the input and output data.
- Connect a square-wave signal to the “D” input with an amplitude of 2.4 to 3.3 V.
- Look for the complementary “A” and “B” outputs on an oscilloscope.

Circuit Diagram

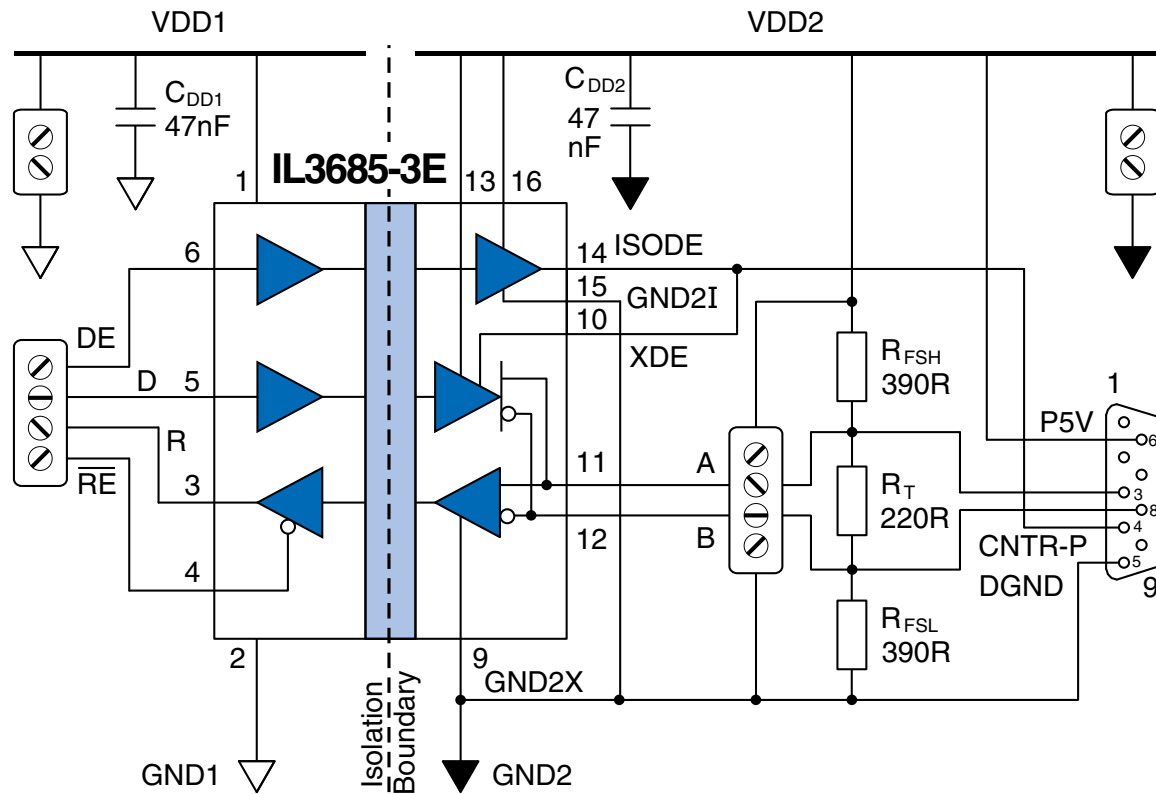

Device pin	Symbol	Description
1	VDD1	Input power supply
2	GND1	Input power supply ground return
3	R	Output data from bus
4	\overline{RE}	Read data enable (R=high impedance if \overline{RE} is high)
5	D	Data input to bus
6	DE	Drive enable
7	NC	No internal connection
8	NC	No internal connection
9	GND2X	Output transceiver ground return (normally connected to pin 15)
10	XDE	Transceiver Device Enable (normally connected to pin 14)
11	A	Non-inverting bus line
12	B	Inverting bus line
13	VDD2X	Output transceiver power supply (normally connected to pin 16)
14	ISODE	Isolated DE output (normally connected to pin 10)
15	GND2I	Output isolation power supply ground return (normally connected to pin 9)
16	VDD2I	Output power supply (normally connected to pin 13)

Board Layout and Cabling

Board Layout Best Practices

Although not always necessary, the following connector layout precautions are best practices:

- The connector, termination resistor, and transceiver should be as close together as possible.
- Use 47 nF decoupling capacitors as close as possible to the transceiver V_{DD} pins.
- Provide ground planes for both power supplies.

Cable Specifications

PROFIBUS Type A bus cable is recommended for high transmission speeds (more than 500 Kbps). Type B should only be used at low baud rates and low requirements on the network distances.

Cable Length

IL3685 transceivers are intended for networks up to 4,000 feet (1,200 m) with Type A bus cable and proper termination. The maximum data rate decreases as cable length increases.

Differential Bus Output Voltage

Unlike many other PROFIBUS transceivers, the IL3685 meets stringent PROFIBUS standards for transceiver differential output voltage. Some transceivers manufacturers erroneously believe maximizing differential output voltage is a good thing.

The PROFIBUS specification requires:

“The differential voltage between A- and B-line shall be a minimum of 4 V and a maximum of 7 V.”

Unfortunately, most RS-485 transceiver don't specify bus voltages that way. They specify a maximum and a minimum differential voltage between A and B. Differential maximum and minimum is almost always quoted with a single output state under low and high loads respectively.

The PROFIBUS specification is with respect to terminal A of the bus, however. When A is greater than B, a negative voltage is measured with respect to A.

With no load, the voltage measured will be approximately -3.2 V for compatible transceivers. When the opposite logic state is driven from TxD, the B node will become positive with respect to A.

Biasing and Termination

Internal Biasing Resistors

“Fail-safe biasing” forces a logic high state on “R” in response to an open-circuit condition between the bus “A” and “B” lines, or when no drivers are active on the bus. IL3000-Series Isolated Transceivers include internal pull-up and pull-down resistors of approximately 30 k Ω in the receiver section (R_{FS-INT} in the figure below):

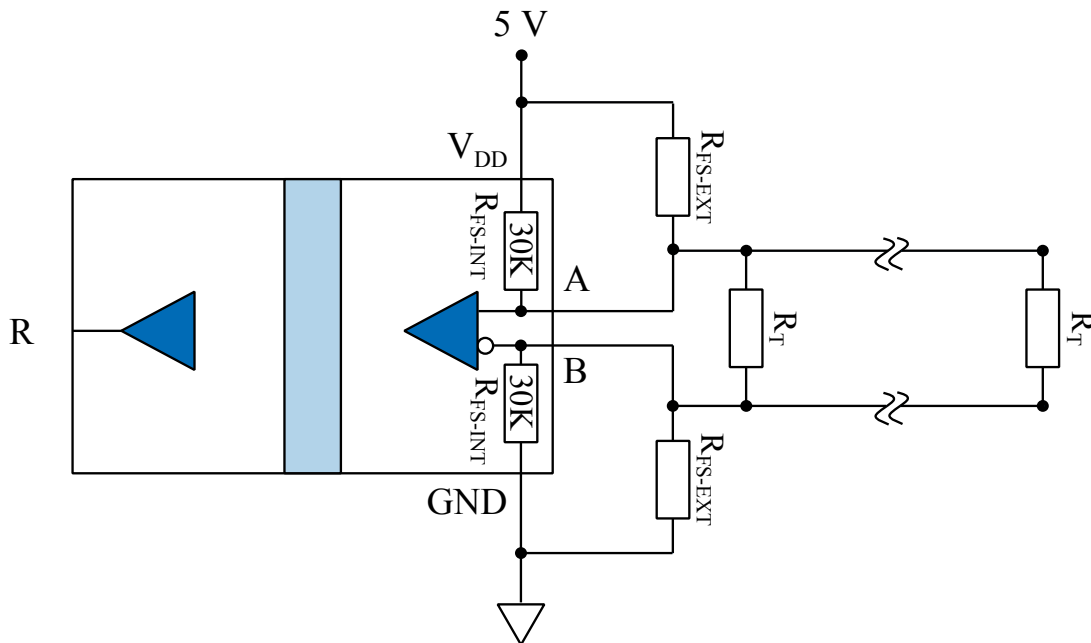

These internal resistors ensure fail-safe operation if there are no termination resistors and up to four RS-485 worst-case Unit Loads of 12 k Ω .

Termination Resistor

The evaluation board has a 220 Ω termination resistor, which is standard for PROFIBUS. The resistor should be removed if the board is connected to a bus already terminated at both ends.

External Fail-Safe Biasing Resistors

Termination resistors bring the differential voltage across the conductor pair close to zero with no active drivers. In this case, the idle bus is indeterminate and susceptible to noise. External fail-safe biasing resistors (R_{FS-EXT}) at one end of the bus ensure fail-safe operation with a terminated bus. Biasing should provide at least 200 mV across the conductor pair to meet the RS-485 input sensitivity specification.

PROFIBUS-standard 390 Ω fail-safe resistors are included on the evaluation board. If two or more evaluation boards are connected, remove the resistors from all but one board.

Isolated Network Transceivers

NVE offers a wide choice of isolated RS-422 and RS-485 network transceivers.

Versions are available in 0.15-inch and 0.3-inch SOIC packages, as well as ultraminiature QSOP packages. QSOP and 0.15-inch SOIC package are the most compact solutions in the world, and the 0.3-inch SOIC package offers True 8 mm creepage in accordance with IEC60601.

Standard isolation voltage is $2.5 \text{ kV}_{\text{RMS}}$, and ultrahigh-voltage V-Series versions have $6 \text{ kV}_{\text{RMS}}$ isolation voltage.

Transceivers comply with rigorous industry standards. All transceivers are VDE V 0884 certified and UL1577 recognized; the IL3685 is strictly PROFIBUS compliant.

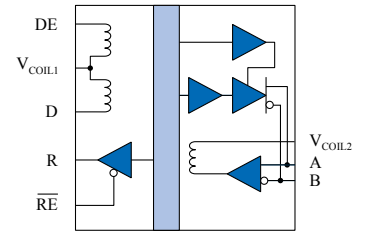
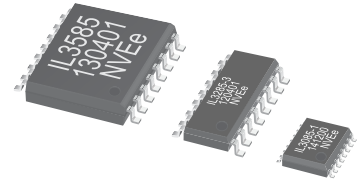

IL3185 / IL3285 / IL3485

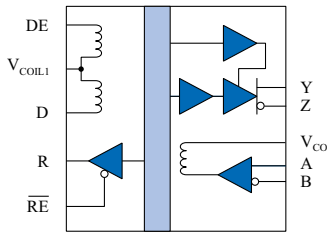

IL3122 / IL3222 / IL3422

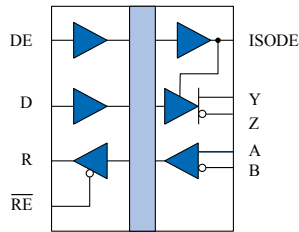

IL422 / IL3022 /
IL3585 / IL3685

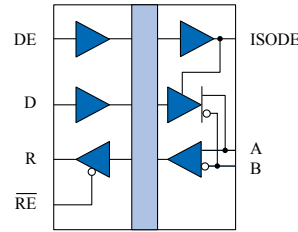

IL485 / IL3085 /
IL3585 / IL3685

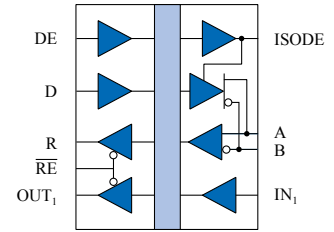

IL485W

Model	Bus	Inputs	Mbps	Nodes	Bus ESD	Key Features	Available Packages
IL3122	RS-422	Passive	5	32	15 kV	Low Cost	0.15" SOIC-16; 0.3" SOIC-16
IL3185	RS-485	Passive	5	32	15 kV	Low Cost	0.15" SOIC-16; 0.3" SOIC-16
IL3222	RS-422	Passive	5	256	15 kV	Fractional Load	0.15" SOIC-16; 0.3" SOIC-16
IL3285	RS-485	Passive	5	256	15 kV	Fractional Load	0.15" SOIC-16; 0.3" SOIC-16
IL3422	RS-422	Passive	20	32	15 kV	High Speed	0.15" SOIC-16; 0.3" SOIC-16
IL3485	RS-485	Passive	20	32	15 kV	High Speed	0.15" SOIC-16; 0.3" SOIC-16
IL422	RS-422	Digital	25	32	15 kV	Legacy Standard	0.3" SOIC-16
IL485	RS-485	Digital	35	32	2 kV	Legacy Standard	0.3" SOIC-16
IL485W	RS-485	Digital	35	32	2 kV	Handshake Line	0.3" SOIC-16
IL3022	RS-422	Digital	4	32	7.5 kV	Low Cost	0.3" SOIC-16
IL3085	RS-485	Digital	4	32	15 kV	Low Cost	QSOP16; 0.15" SOIC-16; 0.3" SOIC-16
IL3522	RS-422	Digital	40	50	15 kV	Very High Speed	0.3" SOIC-16
IL3585	RS-485	Digital	40	50	15 kV	Very High Speed	0.15" SOIC-16; 0.3" SOIC-16
IL3685	RS-485	Digital	40	50	15 kV	PROFIBUS	QSOP16; 0.15" SOIC-16; 0.3" SOIC-16

Limited Warranty and Liability

Information in this document is believed to be accurate and reliable. However, NVE does not give any representations or warranties, expressed or implied, as to the accuracy or completeness of such information and shall have no liability for the consequences of use of such information. In no event shall NVE be liable for any indirect, incidental, punitive, special or consequential damages (including, without limitation, lost profits, lost savings, business interruption, costs related to the removal or replacement of any products or rework charges) whether or not such damages are based on tort (including negligence), warranty, breach of contract or any other legal theory.

Right to Make Changes

NVE reserves the right to make changes to information published in this document including, without limitation, specifications and product descriptions at any time and without notice.

Use in Life-Critical or Safety-Critical Applications

Unless NVE and a customer explicitly agree otherwise in writing, NVE products are not designed, authorized or warranted to be suitable for use in life support, life-critical or safety-critical devices or equipment. NVE accepts no liability for inclusion or use of NVE products in such applications and such inclusion or use is at the customer's own risk. Should the customer use NVE products for such application whether authorized by NVE or not, the customer shall indemnify and hold NVE harmless against all claims and damages.

Applications

Applications described in this document are illustrative only. NVE makes no representation or warranty that such applications will be suitable for the specified use without further testing or modification. Customers are responsible for the design and operation of their applications and products using NVE products, and NVE accepts no liability for any assistance with applications or customer product design. It is customer's sole responsibility to determine whether the NVE product is suitable and fit for the customer's applications and products planned, as well as for the planned application and use of customer's third party customers. Customers should provide appropriate design and operating safeguards to minimize the risks associated with their applications and products. NVE does not accept any liability related to any default, damage, costs or problem which is based on any weakness or default in the customer's applications or products, or the application or use by customer's third party customers. The customer is responsible for all necessary testing for the customer's applications and products using NVE products in order to avoid a default of the applications and the products or of the application or use by customer's third party customers. NVE accepts no liability in this respect.

An ISO 9001 Certified Company

NVE Corporation
11409 Valley View Road
Eden Prairie, MN 55344-3617

©NVE Corporation

All rights are reserved. Reproduction in whole or in part is prohibited without the prior written consent of the copyright owner.

Manual No.: ISB-CB-009

November 2017