

## General Description

The AOZ1019 is a high efficiency, simple to use, 2A buck regulator. The AOZ1019 works from a 4.5V to 16V input voltage range, and provides up to 2A of continuous output current with an output voltage adjustable down to 0.8V.

The AOZ1019 comes in an SO-8 package and is rated over a -40°C to +85°C ambient temperature range.

## Features

- 4.5V to 16V operating input voltage range
- 130mΩ internal PFET switch for high efficiency: up to 95%
- Internal soft start
- Output voltage adjustable to 0.8V
- 2A continuous output current
- Fixed 500kHz PWM operation
- Cycle-by-cycle current limit
- Short-circuit protection
- Under voltage lockout
- Output over voltage protection
- Thermal shutdown
- Small size SO-8 package

## Applications

- Point of load DC/DC conversion
- PCIe graphics cards
- Set top boxes
- DVD drives and HDD
- LCD panels
- Cable modems
- Telecom/Networking/Datacom equipment

## Typical Application

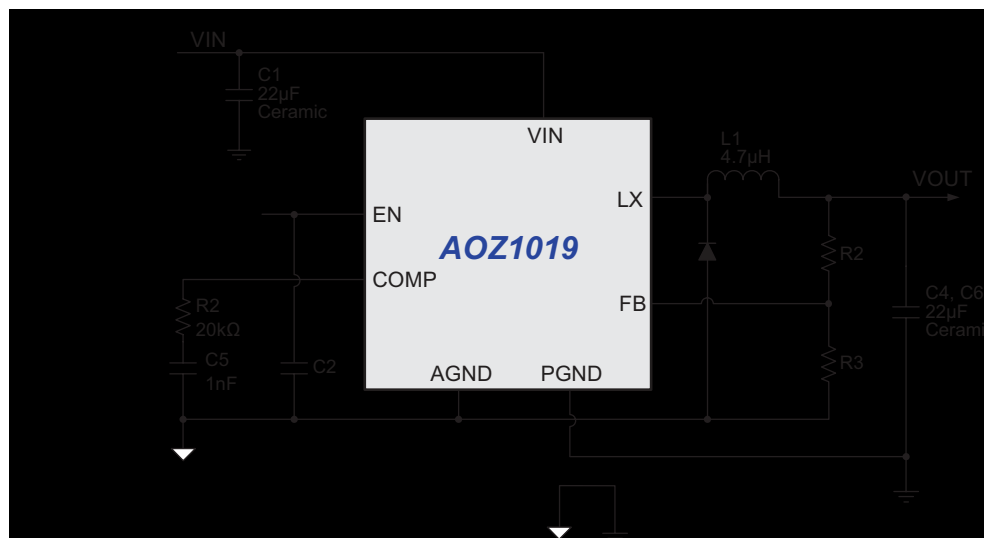
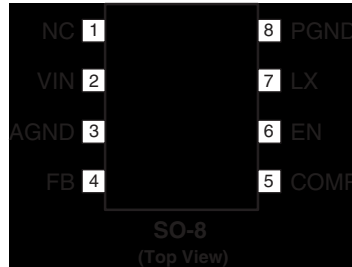

Figure 1. 3.3V/2A Buck Regulator

### Ordering Information

Part Number	Ambient Temperature Range	Package	Environmental
AOZ1019AI	-40°C to +85°C	SO-8	RoHS

### Pin Configuration



### Pin Description

Pin Number	Pin Name	Pin Function
1	NC	Not connected.
2	V <sub>IN</sub>	Supply voltage input. When V <sub>IN</sub> rises above the UVLO threshold the device starts up.
3	AGND	Reference connection for controller section. Also used as thermal connection for controller section. Electrically needs to be connected to PGND.
4	FB	The FB pin is used to determine the output voltage via a resistor divider between the output and GND.
5	COMP	External loop compensation pin.
6	EN	The enable pin is active high. Connect EN pin to V <sub>IN</sub> if not used. Do not leave the EN pin floating.
7	LX	PWM output connection to inductor. Thermal connection for output stage.
8	PGND	Power ground. Electrically needs to be connected to AGND.

### Block Diagram

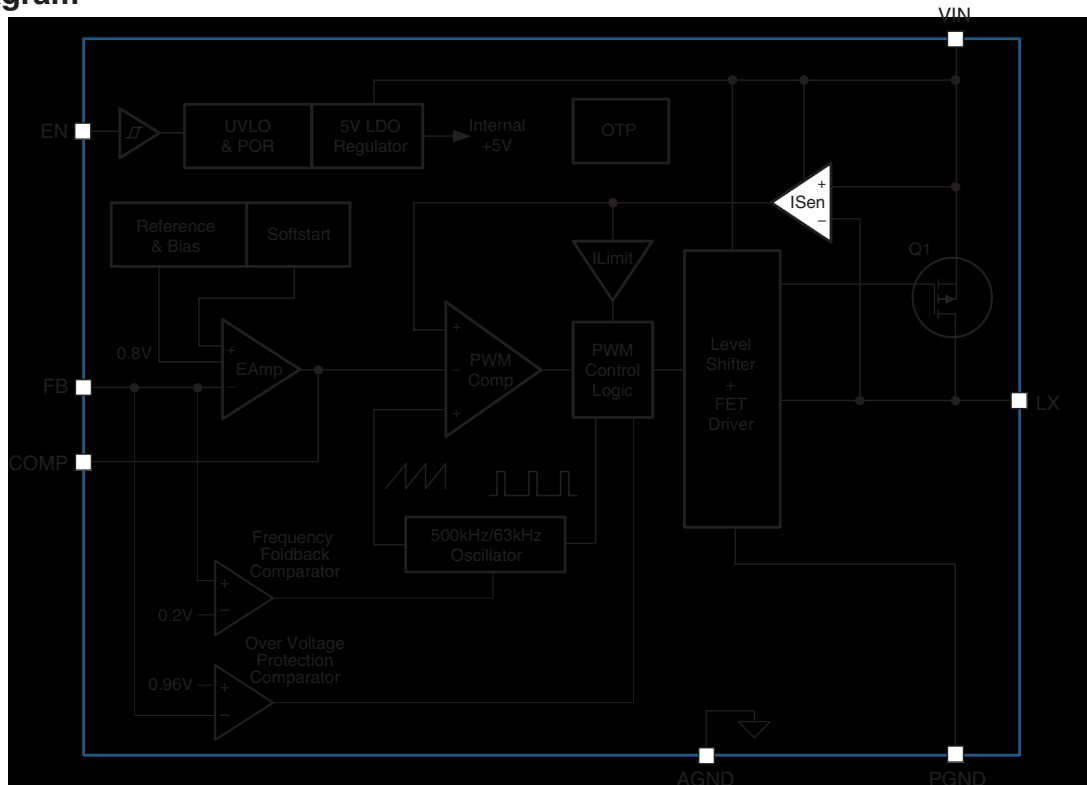

## Absolute Maximum Ratings

Exceeding the Absolute Maximum ratings may damage the device.

Parameter	Rating
Supply Voltage ( $V_{IN}$ )	18V
LX to AGND	-0.7V to $V_{IN}+0.3V$
EN to AGND	-0.3V to $V_{IN}+0.3V$
FB to AGND	-0.3V to 6V
COMP to AGND	-0.3V to 6V
PGND to AGND	-0.3V to +0.3V
Junction Temperature ( $T_J$ )	+150°C
Storage Temperature ( $T_S$ )	-65°C to +150°C
ESD Rating: Human Body Model <sup>(1)</sup>	2kV
Machine Model	200V

**Note:**

1. Devices are inherently ESD sensitive, handling precautions are required. Human body model rating: 1.5k $\Omega$  in series with 100pF.

## Recommend Operating Ratings

The device is not guaranteed to operate beyond the Maximum Operating Ratings.

Parameter	Rating
Supply Voltage ( $V_{IN}$ )	4.5V to 16V
Output Voltage Range	0.8V to $V_{IN}$
Ambient Temperature ( $T_A$ )	-40°C to +85°C
Package Thermal Resistance SO-8 ( $\Theta_{JA}$ ) <sup>(2)</sup>	87°C/W

**Note:**

2. The value of  $\Theta_{JA}$  is measured with the device mounted on 1-in<sup>2</sup> FR-4 board with 2oz. Copper, in a still air environment with  $T_A = 25^\circ\text{C}$ . The value in any given application depends on the user's specific board design.

## Electrical Characteristics

$T_A = 25^\circ\text{C}$ ,  $V_{IN} = V_{EN} = 12V$ ,  $V_{OUT} = 3.3V$  unless otherwise specified<sup>(3)</sup>

Symbol	Parameter	Conditions	Min.	Typ.	Max.	Units
$V_{IN}$	Supply Voltage		<b>4.5</b>		<b>16</b>	V
$V_{UVLO}$	Input Under-Voltage Lockout Threshold	$V_{IN}$ Rising $V_{IN}$ Falling		<b>4.00</b> <b>3.70</b>		V
$I_{IN}$	Supply Current (Quiescent)	$I_{OUT} = 0$ , $V_{FB} = 1.2V$ , $V_{EN} > 1.2V$		<b>2</b>	<b>3</b>	mA
$I_{OFF}$	Shutdown Supply Current	$V_{EN} = 0V$		<b>1</b>	<b>10</b>	$\mu\text{A}$
$V_{FB}$	Feedback Voltage		0.782	0.8	0.818	V
	Load Regulation			0.5		%
	Line Regulation			0.5		%
$I_{FB}$	Feedback Voltage Input Current				200	nA
$V_{EN}$	EN Input Threshold	Off Threshold On Threshold	<b>2.0</b>		<b>0.6</b>	V
$V_{HYS}$	EN Input Hysteresis			<b>100</b>		mV
$I_{EN}$	EN Input Current				1	$\mu\text{A}$
<b>MODULATOR</b>						
$f_O$	Frequency		400	500	600	kHz
$D_{MAX}$	Maximum Duty Cycle		100			%
$D_{MIN}$	Minimum Duty Cycle				6	%
	Error Amplifier Voltage Gain			500		V/V
	Error Amplifier Transconductance			200		$\mu\text{A/V}$
<b>PROTECTION</b>						
$I_{LIM}$	Current Limit		2.5		3.6	A
$V_{PR}$	Output Over-Voltage Protection Threshold	Off Threshold On Threshold	920 820	960 860	1000 900	mV
	Over-Temperature Shutdown Limit			150		°C
$t_{SS}$	Soft Start Interval			2.2		ms
<b>OUTPUT STAGE</b>						
	High-Side Switch On-Resistance	$V_{IN} = 12V$ $V_{IN} = 5V$		97 166	130 200	m $\Omega$

**Note:**

3. Specification in **BOLD** indicate an ambient temperature range of -40°C to +85°C. These specifications are guaranteed by design.

## Typical Performance Characteristics

Circuit of Figure 1.  $T_A = 25^\circ\text{C}$ ,  $V_{IN} = V_{EN} = 12\text{V}$ ,  $V_{OUT} = 3.3\text{V}$  unless otherwise specified.

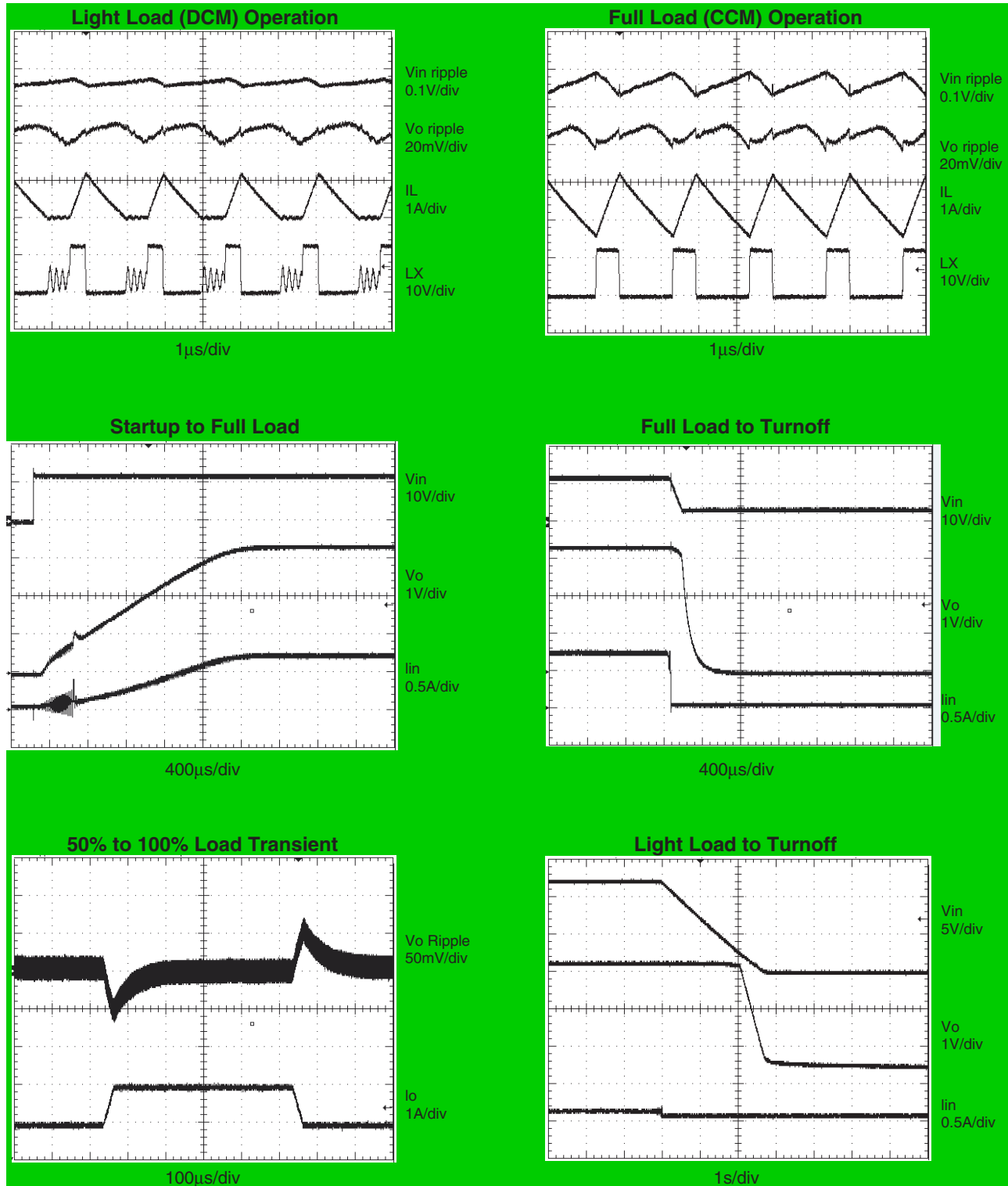

**Typical Performance Characteristics (Continued)**

Circuit of Figure 1.  $T_A = 25^\circ\text{C}$ ,  $V_{IN} = V_{EN} = 12\text{V}$ ,  $V_{OUT} = 3.3\text{V}$  unless otherwise specified.

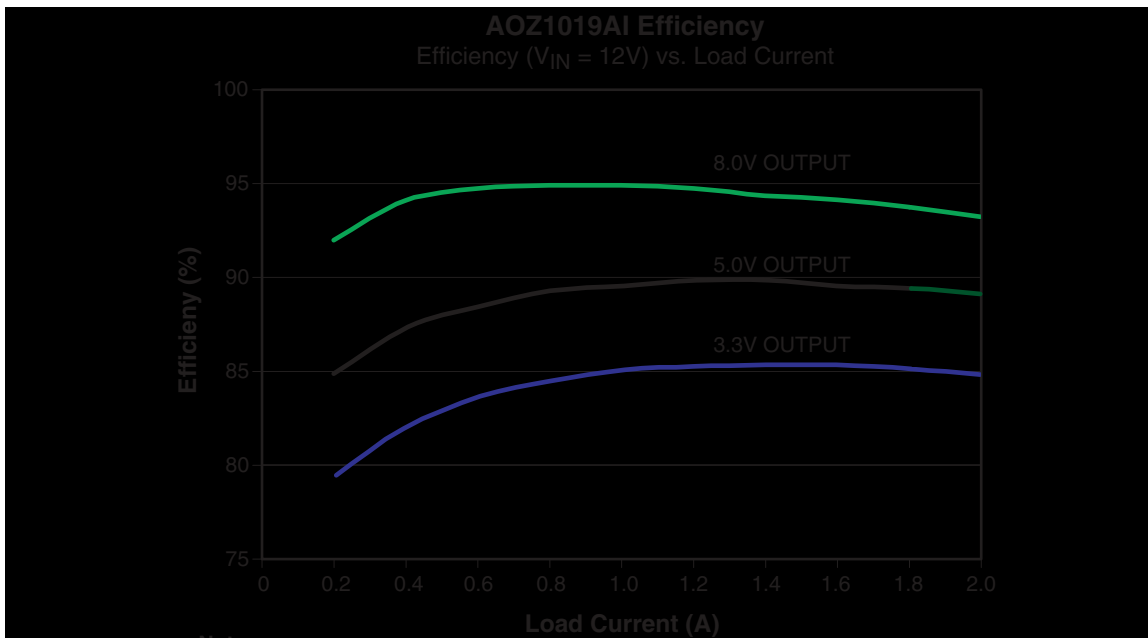
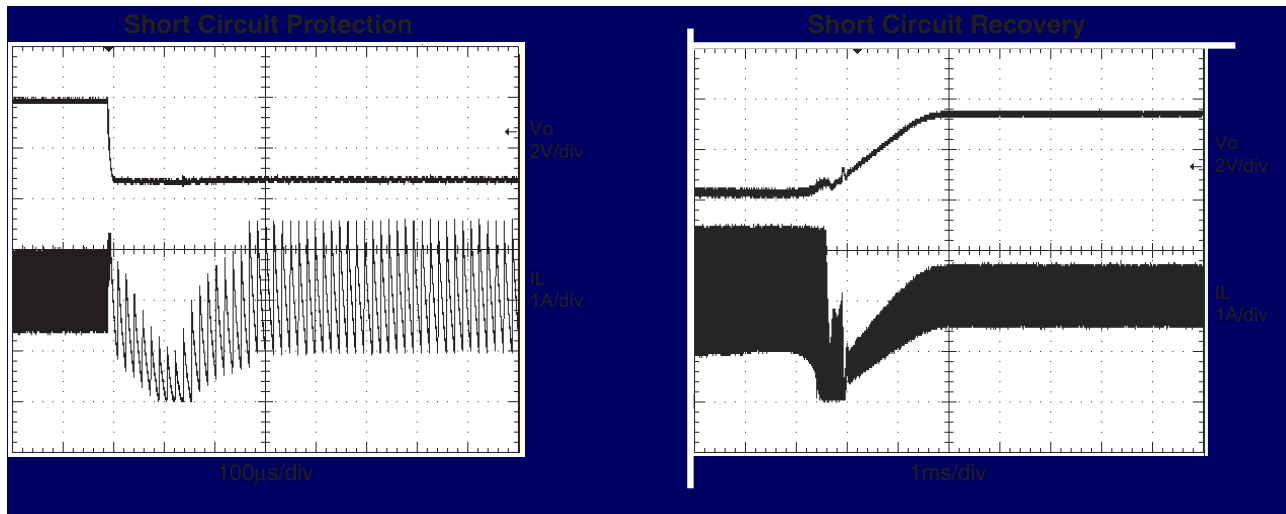

**Note:**

4. Thermal de-rating curves for SO-8 package part under typical input and output condition based on the evaluation board.  $25^\circ\text{C}$  ambient temperature and natural convection (air speed <50LFM) unless otherwise specified.

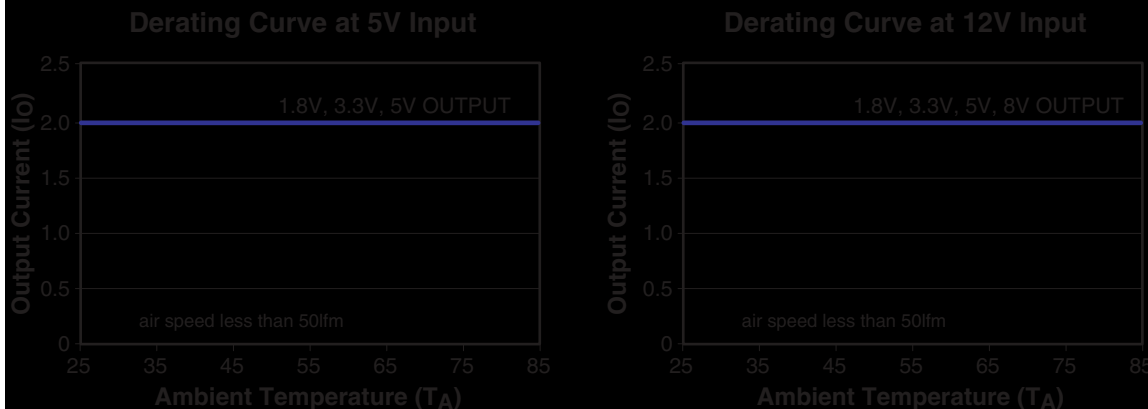

## Detailed Description

The AOZ1019 is a current-mode step down regulator with integrated high side PMOS switch. It operates from a 4.5V to 16V input voltage range and supplies up to 2A of load current. The duty cycle can be adjusted from 6% to 100% allowing a wide range of output voltage. Features include enable control, Power-On Reset, input under voltage lockout, fixed internal soft-start and thermal shut down.

The AOZ1019 is available in SO-8 package.

### Enable and Soft Start

The AOZ1019 has an internal soft start feature to limit in-rush current and ensure the output voltage ramps up smoothly to regulation voltage. A soft start process begins when the input voltage rises to 4.0V and voltage on EN pin is HIGH. In soft start process, the output voltage is ramped to regulation voltage in typically 2.2ms. The 2.2ms soft start time is set internally.

The EN pin of the AOZ1019 is active HIGH. Connect the EN pin to  $V_{IN}$  if enable function is not used. Pulling EN to ground will disable the AOZ1019. Do not leave it open. The voltage on EN pin must be above 2.0 V to enable the AOZ1019. When voltage on EN pin falls below 0.6V, the AOZ1019 is disabled. If an application circuit requires the AOZ1019 to be disabled, an open drain or open collector circuit should be used to interface to the EN pin.

### Steady-State Operation

Under steady-state conditions, the converter operates in fixed frequency and Continuous-Conduction Mode (CCM).

The AOZ1019 integrates an internal P-MOSFET as the high-side switch. Inductor current is sensed by amplifying the voltage drop across the drain to source of the high side power MOSFET. Output voltage is divided down by the external voltage divider at the FB pin. The difference of the FB pin voltage and reference is amplified by the internal transconductance error amplifier. The error voltage, which shows on the COMP pin, is compared against the current signal, which is sum of inductor current signal and ramp compensation signal, at PWM comparator input. If the current signal is less than the error voltage, the internal high-side switch is on. The inductor current flows from the input through the inductor to the output. When the current signal exceeds the error voltage, the high-side switch is off. The inductor current is freewheeling through the internal Schottky diode to output.

The AOZ1019 uses a P-Channel MOSFET as the high side switch. It saves the bootstrap capacitor normally seen in a circuit using an NMOS switch. It allows 100% turn-on of the upper switch to achieve linear regulation mode of operation. The minimum voltage drop from  $V_{IN}$  to  $V_O$  is the load current x DC resistance of MOSFET + DC resistance of buck inductor. It can be calculated by equation below:

$$V_{O\_MAX} = V_{IN} - I_O \times (R_{DS(ON)} + R_{inductor})$$

where;

$V_{O\_MAX}$  is the maximum output voltage,

$V_{IN}$  is the input voltage from 4.5V to 16V,

$I_O$  is the output current from 0A to 2A,

$R_{DS(ON)}$  is the on resistance of internal MOSFET, the value is between 97m $\Omega$  and 200m $\Omega$  depending on input voltage and junction temperature, and

$R_{inductor}$  is the inductor DC resistance.

### Switching Frequency

The AOZ1019 switching frequency is fixed and set by an internal oscillator. The actual switching frequency ranges from 400kHz to 600kHz due to device variation.

### Output Voltage Programming

Output voltage can be set by feeding back the output to the FB pin with a resistor divider network as shown in Figure 1. The resistor divider network includes  $R_2$  and  $R_3$ . Typically, a design is started by picking a fixed  $R_3$  value and calculating the required  $R_2$  with equation below.

$$V_O = 0.8 \times \left( 1 + \frac{R_2}{R_3} \right)$$

Some standard value of  $R_2$ ,  $R_3$  for most commonly used output voltage values are listed in Table 1.

**Table 1.**

$V_O$ (V)	$R_2$ (k $\Omega$ )	$R_3$ (k $\Omega$ )
0.8	1.0	Open
1.2	4.99	10
1.5	10	11.5
1.8	12.7	10.2
2.5	21.5	10
3.3	31.6	10
5.0	52.3	10

The combination of R<sub>2</sub> and R<sub>3</sub> should be large enough to avoid drawing excessive current from the output, which will cause power loss.

Since the switch duty cycle can be as high as 100%, the maximum output voltage can be set as high as the input voltage minus the voltage drop on upper PMOS and inductor.

## Protection Features

The AOZ1019 has multiple protection features to prevent system circuit damage under abnormal conditions.

### Over Current Protection (OCP)

The sensed inductor current signal is also used for over current protection. Since the AOZ1019 employs peak current mode control, the COMP pin voltage is proportional to the peak inductor current. The COMP pin voltage is limited to be between 0.4V and 2.5V internally. The peak inductor current is automatically limited cycle by cycle.

The cycle by cycle current limit threshold is set between 2.5A and 3.6A. When the load current reaches the current limit threshold, the cycle by cycle current limit circuit turns off the high side switch immediately to terminate the current duty cycle. The inductor current stop rising. The cycle by cycle current limit protection directly limits inductor peak current. The average inductor current is also limited due to the limitation on peak inductor current. When cycle by cycle current limit circuit is triggered, the output voltage drops as the duty cycle decreasing.

The AOZ1019 has internal short circuit protection to protect itself from catastrophic failure under output short circuit conditions. The FB pin voltage is proportional to the output voltage. Whenever FB pin voltage is below 0.2V, the short circuit protection circuit is triggered. As a result, the converter is shut down and hiccups at a frequency equals to 1/8 of normal switching frequency. The converter will start up via a soft start once the short circuit condition disappears. In short circuit protection mode, the inductor average current is greatly reduced because of the low hiccup frequency.

### Output Over Voltage Protection (OVP)

The AOZ1019 monitors the feedback voltage: when the feedback voltage is higher than 960mV, it immediate turns-off the PMOS to protect the output voltage overshoot at fault condition. When feedback voltage is lower than 860mV, the PMOS is allowed to turn on in the next cycle.

### Power-On Reset (POR)

A power-on reset circuit monitors the input voltage. When the input voltage exceeds 4V, the converter starts operation. When input voltage falls below 3.7V, the converter will stop switching.

### Schottky Diode Selection

The external freewheeling diode supplies the current to the inductor when the high side PMOS switch is off. To reduce the losses due to the forward voltage drop and recovery of diode, Schottky diode is recommended to use. The maximum reverse voltage rating of the chosen Schottky diode should be greater than the maximum input voltage, and the current rating should be greater than the maximum load current.

### Thermal Protection

An internal temperature sensor monitors the junction temperature. It shuts down the internal control circuit and high side PMOS if the junction temperature exceeds 150°C.

## Application Information

The basic AOZ1019 application circuit is shown in Figure 1. Component selection is explained below.

### Input Capacitor

The input capacitor (C1 in Figure 1) must be connected to the V<sub>IN</sub> pin and PGND pin of the AOZ1019 to maintain steady input voltage and filter out the pulsing input current. A small decoupling capacitor (Cd in Figure 1), usually 1μF, should be connected to the V<sub>IN</sub> pin and AGND pin for stable operation of the AOZ1019. The voltage rating of input capacitor must be greater than maximum input voltage plus ripple voltage.

The input ripple voltage can be approximated by equation below:

$$\Delta V_{IN} = \frac{I_O}{f \times C_{IN}} \times \left(1 - \frac{V_O}{V_{IN}}\right) \times \frac{V_O}{V_{IN}}$$

Since the input current is discontinuous in a buck converter, the current stress on the input capacitor is another concern when selecting the capacitor. For a buck circuit, the RMS value of input capacitor current can be calculated by:

$$I_{CIN\_RMS} = I_O \times \sqrt{\frac{V_O}{V_{IN}} \left(1 - \frac{V_O}{V_{IN}}\right)}$$



if let  $m$  equal the conversion ratio:

$$\frac{V_O}{V_{IN}} = m$$

The relation between the input capacitor RMS current and voltage conversion ratio is calculated and shown in Figure 2 below. It can be seen that when  $V_O$  is half of  $V_{IN}$ ,  $C_{IN}$  is under the worst current stress. The worst current stress on  $C_{IN}$  is  $0.5 \times I_O$ .

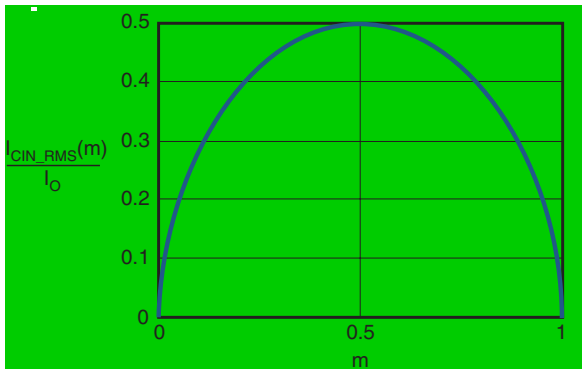

Figure 2.  $I_{CIN}$  vs. Voltage Conversion Ratio

For reliable operation and best performance, the input capacitors must have current rating higher than  $I_{CIN\_RMS}$  at worst operating conditions. Ceramic capacitors are preferred for input capacitors because of their low ESR and high ripple current rating. Depending on the application circuits, other low ESR tantalum capacitor or aluminum electrolytic capacitor may also be used. When selecting ceramic capacitors, X5R or X7R type dielectric ceramic capacitors are preferred for their better temperature and voltage characteristics. Note that the ripple current rating from capacitor manufactures is based on certain amount of life time. Further de-rating may be necessary for practical design requirement.

### Inductor

The inductor is used to supply constant current to output when it is driven by a switching voltage. For a given input and output voltage, inductance and switching frequency together decide the inductor ripple current, which is,

$$\Delta I_L = \frac{V_O}{f \times L} \times \left(1 - \frac{V_O}{V_{IN}}\right)$$

The peak inductor current is:

$$I_{Lpeak} = I_O + \frac{\Delta I_L}{2}$$

High inductance gives low inductor ripple current but requires larger size inductor to avoid saturation. Low ripple current reduces inductor core losses. It also

reduces RMS current through the inductor and switches, which results in less conduction loss. Usually, peak to peak ripple current on inductor is designed to be 20% to 30% of output current.

When selecting the inductor, make sure it is able to handle the peak current without saturation, even at the highest operating temperature.

The inductor takes the highest current in a buck circuit. The conduction loss on the inductor needs to be checked for thermal and efficiency requirements.

Surface mount inductors in different shape and styles are available from Coilcraft, Elytone and Murata. Shielded inductors are small and radiate less EMI noise. However, they cost more than unshielded inductors. The choice depends on EMI requirement, price and size.

### Output Capacitor

The output capacitor is selected based on the DC output voltage rating, output ripple voltage specification and ripple current rating.

The selected output capacitor must have a higher rated voltage specification than the maximum desired output voltage including ripple. De-rating needs to be considered for long term reliability.

Output ripple voltage specification is another important factor for selecting the output capacitor. In a buck converter circuit, output ripple voltage is determined by inductor value, switching frequency, output capacitor value and ESR. It can be calculated by the equation below:

$$\Delta V_O = \Delta I_L \times \left(ESR_{CO} + \frac{1}{8 \times f \times C_O}\right)$$

where;

$C_O$  is output capacitor value and

$ESR_{CO}$  is the Equivalent Series Resistor of output capacitor.

When low ESR ceramic capacitor is used as output capacitor, the impedance of the capacitor at the switching frequency dominates. Output ripple is mainly caused by capacitor value and inductor ripple current. The output ripple voltage calculation can be simplified to:

$$\Delta V_O = \Delta I_L \times ESR_{CO}$$

If the impedance of ESR at switching frequency dominates, the output ripple voltage is mainly decided by capacitor ESR and inductor ripple current. The output ripple voltage calculation can be further simplified to:

$$\Delta V_O = \Delta I_L \times ESR_{CO}$$



For lower output ripple voltage across the entire operating temperature range, X5R or X7R dielectric type of ceramic, or other low ESR tantalum are recommended to be used as output capacitors.

In a buck converter, output capacitor current is continuous. The RMS current of output capacitor is decided by the peak to peak inductor ripple current. It can be calculated by:

$$I_{CO\_RMS} = \frac{\Delta I_L}{\sqrt{12}}$$

Usually, the ripple current rating of the output capacitor is a smaller issue because of the low current stress. When the buck inductor is selected to be very small and inductor ripple current is high, output capacitor could be overstressed.

### Loop Compensation

The AOZ1019 employs peak current mode control for easy use and fast transient response. Peak current mode control eliminates the double pole effect of the output L&C filter. It greatly simplifies the compensation loop design.

With peak current mode control, the buck power stage can be simplified to be a one-pole and one-zero system in frequency domain. The pole is dominant pole and can be calculated by:

$$f_{p1} = \frac{1}{2\pi \times C_O \times R_L}$$

The zero is a ESR zero due to output capacitor and its ESR. It is can be calculated by:

$$f_{z1} = \frac{1}{2\pi \times C_O \times ESR_{CO}}$$

where;

$C_O$  is the output filter capacitor,

$R_L$  is load resistor value, and

$ESR_{CO}$  is the equivalent series resistance of output capacitor.

The compensation design is actually to shape the converter close loop transfer function to get desired gain and phase. Several different types of compensation network can be used for AOZ1019. For most cases, a series capacitor and resistor network connected to the COMP pin sets the pole-zero and is adequate for a stable high-bandwidth control loop.

In the AOZ1019, the FB and COMP pins are the inverting input and the output of internal transconductance error amplifier. A series R and C compensation network connected to COMP provides one pole and one zero. The pole is:

$$f_{p2} = \frac{G_{EA}}{2\pi \times C_C \times G_{VEA}}$$

where;

$G_{EA}$  is the error amplifier transconductance, which is  $200 \times 10^{-6}$  A/V,

$G_{VEA}$  is the error amplifier voltage gain, which is 500 V/V, and  $C_C$  is compensation capacitor.

The zero given by the external compensation network, capacitor  $C_C$  (C5 in Figure 1) and resistor  $R_C$  (R1 in Figure 1), is located at:

$$f_{z2} = \frac{1}{2\pi \times C_C \times R_C}$$

To design the compensation circuit, a target crossover frequency  $f_C$  for close loop must be selected. The system crossover frequency is where control loop has unity gain. The crossover frequency is also called the converter bandwidth. Generally a higher bandwidth means faster response to load transient. However, the bandwidth should not be too high due to system stability concern. When designing the compensation loop, converter stability under all line and load condition must be considered.

Usually, it is recommended to set the bandwidth to be less than 1/10 of switching frequency. The AOZ1019 operates at a fixed switching frequency range from 400kHz to 600kHz. It is recommended to choose a crossover frequency less than 50kHz.

The strategy for choosing  $R_C$  and  $C_C$  is to set the cross over frequency with  $R_C$  and set the compensator zero with  $C_C$ . Using selected crossover frequency,  $f_C$ , to calculate  $R_C$ :

$$R_C = f_C \times \frac{V_O}{V_{FB}} \times \frac{2\pi \times C_O}{G_{EA} \times G_{CS}}$$

where;

$f_C$  is desired crossover frequency,

$V_{FB}$  is 0.8V,

$G_{EA}$  is the error amplifier transconductance, which is  $200 \times 10^{-6}$  A/V, and

$G_{CS}$  is the current sense circuit transconductance, which is 5.64 A/V.

The compensation capacitor  $C_C$  and resistor  $R_C$  together make a zero. This zero is put somewhere close to the dominate pole  $f_{p1}$  but lower than 1/5 of selected cross-over frequency.  $C_C$  can be selected by:

$$C_C = \frac{1.5}{2\pi \times R_C \times f_{p1}}$$

The equation above can also be simplified to:

$$C_C = \frac{C_O \times R_L}{R_C}$$

An easy-to-use application software which helps to design and simulate the compensation loop can be found at [www.aosmd.com](http://www.aosmd.com).

## Thermal Management and Layout Consideration

In the AOZ1019 buck regulator circuit, high pulsing current flows through two circuit loops. The first loop starts from the input capacitors, to the  $V_{IN}$  pin, to the LX pins, to the filter inductor, to the output capacitor and load, and then return to the input capacitor through ground. Current flows in the first loop when the high side switch is on. The second loop starts from inductor, to the output capacitors and load, to the PGND pin of the AOZ1019, to the LX pins of the AOZ1019. Current flows in the second loop when the low side diode is on.

In PCB layout, minimizing the two loops area reduces the noise of this circuit and improves efficiency. A ground plane is recommended to connect input capacitor, output capacitor, and PGND pin of the AOZ1019.

In the AOZ1019 buck regulator circuit, the two major power dissipating components are the AOZ1019 and output inductor. The total power dissipation of converter circuit can be measured by input power minus output power.

$$P_{total\_loss} = V_{IN} \times I_{IN} - V_O \times I_O$$

The power dissipation of inductor can be approximately calculated by output current and DCR of inductor.

$$P_{inductor\_loss} = I_O^2 \times R_{inductor} \times 1.1$$

The power dissipation in Schottky can be approximated as:

$$P_{diode\_loss} = I_O \times (1 - D) \times V_{FWSchottky}$$

The actual AOZ1019 junction temperature can be calculated with power dissipation in the AOZ1019 and thermal impedance from junction to ambient.

$$T_{junction} = \frac{(P_{total\_loss} - P_{inductor\_loss}) \times \Theta_{JA}}{+ T_{ambient}}$$

The maximum junction temperature of AOZ1019 is 150°C, which limits the maximum load current capability. Please see the thermal de-rating curves for the maximum load current of the AOZ1019 under different ambient temperature.

The thermal performance of the AOZ1019 is strongly affected by the PCB layout. Extra care should be taken by users during design process to ensure that the IC will operate under the recommended environmental conditions.

Several layout tips are listed below for the best electric and thermal performance. Figure 3 illustrates a single layer PCB layout example as reference.

1. Do not use thermal relief connection to the  $V_{IN}$  and the PGND pin. Pour a maximized copper area to the PGND pin and the  $V_{IN}$  pin to help thermal dissipation.
2. Input capacitor should be connected to the  $V_{IN}$  pin and the PGND pin as close as possible.
3. A ground plane is preferred. If a ground plane is not used, separate PGND from AGND and connect them only at one point to avoid the PGND pin noise coupling to the AGND pin. In this case, a decoupling capacitor should be connected between  $V_{IN}$  pin and AGND pin.
4. Make the current trace from LX pins to L to Co to the PGND as short as possible.
5. Pour copper plane on all unused board area and connect it to stable DC nodes, like  $V_{IN}$ , GND or  $V_{OUT}$ .
6. The two LX pins are connected to internal PFET drain. They are low resistance thermal conduction path and most noisy switching node. Connected a copper plane to LX pin to help thermal dissipation. This copper plane should not be too larger otherwise switching noise may be coupled to other part of circuit.
7. Keep sensitive signal trace such as trace connected with FB pin and COMP pin far away from the LX pins.

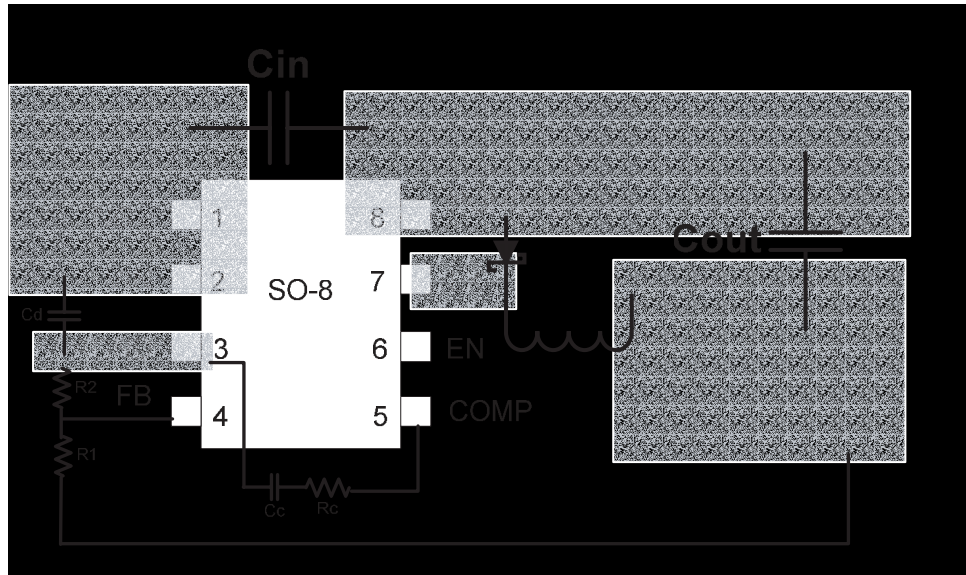
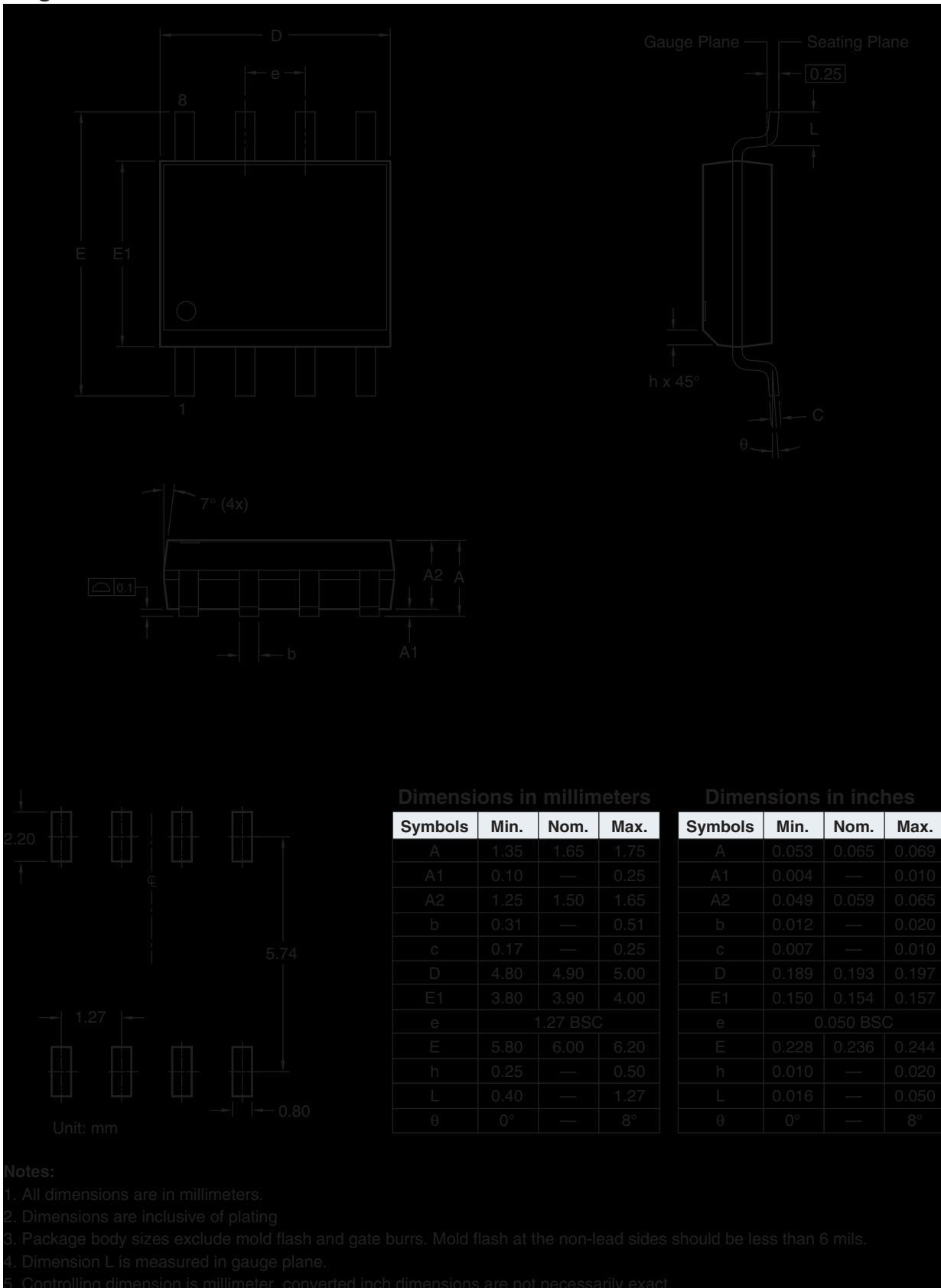

Figure 3. AOZ1019 PCB Layout

**Package Dimensions**



## Tape and Reel Dimensions

### SO-8 Carrier Tape

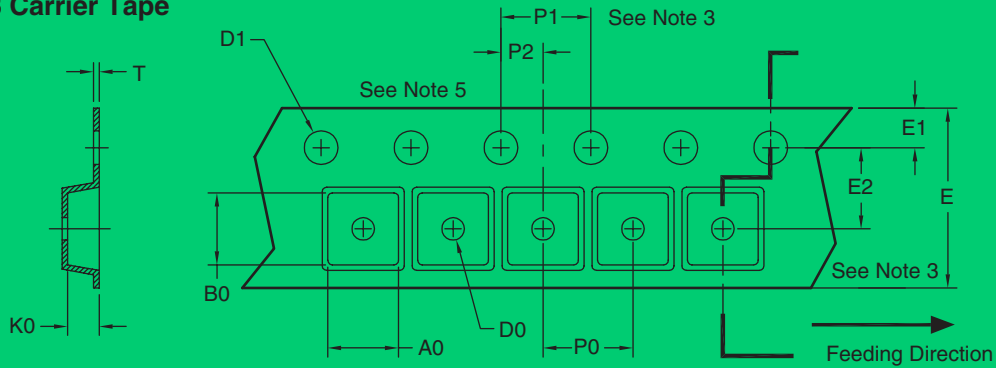

Unit: mm

Package	A0	B0	K0	D0	D1	E	E1	E2	P0	P1	P2	T
SO-8 (12mm)	6.40 $\pm 0.10$	5.20 $\pm 0.10$	2.10 $\pm 0.10$	1.60 $\pm 0.10$	1.50 $\pm 0.10$	12.00 $\pm 0.10$	1.75 $\pm 0.10$	5.50 $\pm 0.10$	8.00 $\pm 0.10$	4.00 $\pm 0.10$	2.00 $\pm 0.10$	0.25 $\pm 0.10$

### SO-8 Reel

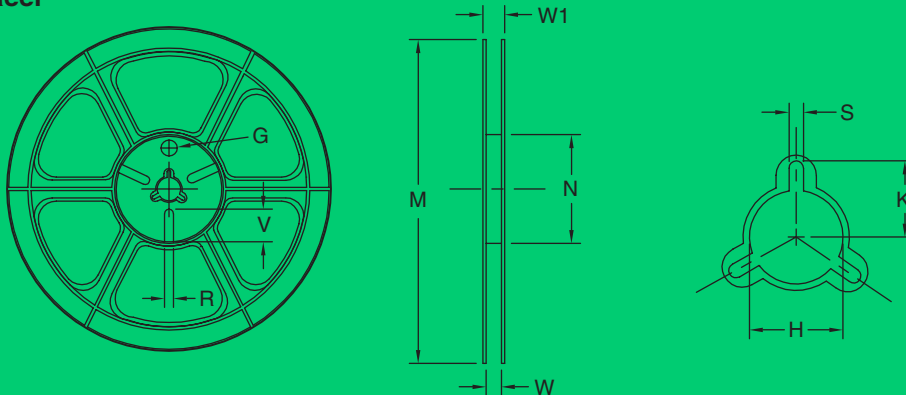

Tape Size	Reel Size	M	N	W	W1	H	K	S	G	R	V
12mm	$\phi 330$	$\phi 330.00$ $\pm 0.50$	$\phi 97.00$ $\pm 0.10$	13.00 $\pm 0.30$	17.40 $\pm 1.00$	$\phi 13.00$ $+0.50/-0.20$	10.60	2.00 $\pm 0.50$	—	—	—

### SO-8 Tape

Leader/Trailer & Orientation

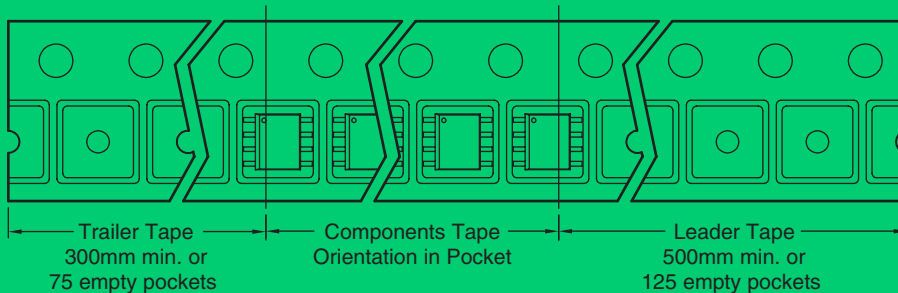

## AOZ1019 Package Marking

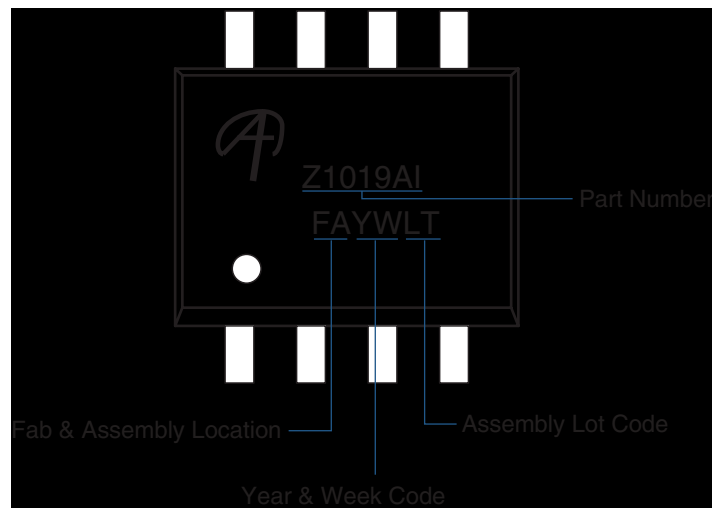

**This datasheet contains preliminary data; supplementary data may be published at a later date. Alpha & Omega Semiconductor reserves the right to make changes at any time without notice.**

### LIFE SUPPORT POLICY

ALPHA & OMEGA SEMICONDUCTOR PRODUCTS ARE NOT AUTHORIZED FOR USE AS CRITICAL COMPONENTS IN LIFE SUPPORT DEVICES OR SYSTEMS.

As used herein:

1. Life support devices or systems are devices or systems which, (a) are intended for surgical implant into the body or (b) support or sustain life, and (c) whose failure to perform when properly used in accordance with instructions for use provided in the labeling, can be reasonably expected to result in a significant injury of the user.

2. A critical component in any component of a life support, device, or system whose failure to perform can be reasonably expected to cause the failure of the life support device or system, or to affect its safety or effectiveness.



Document No.	PO-00004
Version	I

S08 PACKAGE OUTLINE

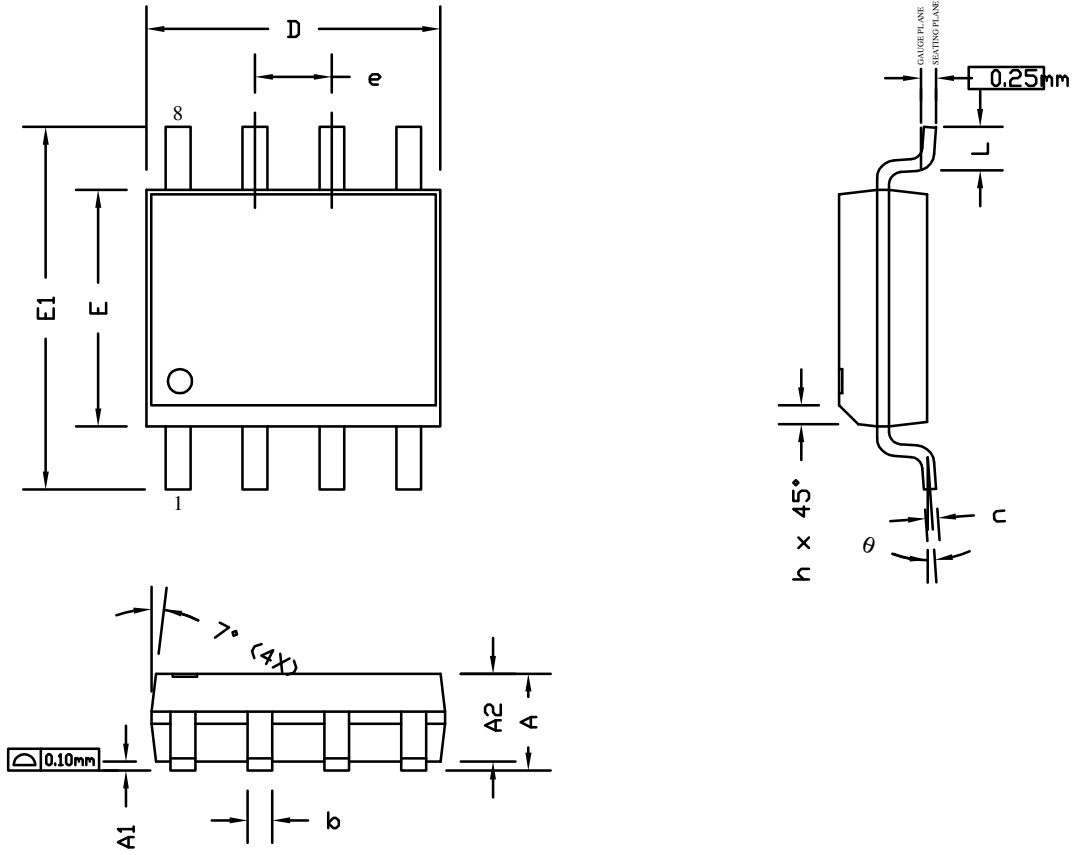

RECOMMENDED LAND PATTERN

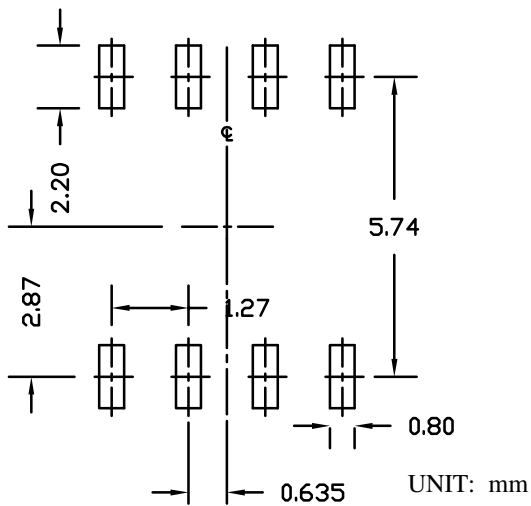

SYMBOLS	DIMENSIONS IN MILLIMETERS			DIMENSIONS IN INCHES		
	MIN	NOM	MAX	MIN	NOM	MAX
A	1.35	1.65	1.75	0.053	0.065	0.069
A1	0.10	0.15	0.25	0.004	0.006	0.010
A2	1.25	1.50	1.65	0.049	0.059	0.065
b	0.31	0.41	0.51	0.012	0.016	0.020
c	0.17	0.20	0.25	0.007	0.008	0.010
D	4.80	4.90	5.00	0.189	0.193	0.197
E	3.80	3.90	4.00	0.150	0.154	0.157
e	1.27 BSC			0.050 BSC		
E1	5.80	6.00	6.20	0.228	0.236	0.244
h	0.25	0.30	0.50	0.010	0.012	0.020
L	0.40	0.69	1.27	0.016	0.027	0.050
θ	0°	4°	8°	0°	4°	8°

NOTE

- ALL DIMENSIONS ARE IN MILLIMETERS.
- DIMENSIONS ARE INCLUSIVE OF PLATING.
- PACKAGE BODY SIZES EXCLUDE MOLD FLASH AND GATE BURRS.  
MOLD FLASH AT THE NON-LEAD SIDES SHOULD BE LESS THAN 6 MILS EACH.
- DIMENSION L IS MEASURED IN GAUGE PLANE.
- CONTROLLING DIMENSION IS MILLIMETER.  
CONVERTED INCH DIMENSIONS ARE NOT NECESSARILY EXACT.



## General Description

The AOZ1019AI evaluation board is a fully assembled and tested circuit board built with the AOZ1019AI buck regulator IC. It outputs an adjustable voltage up to 2A of continuous current. The evaluation board requires an input voltage from 4.5 to 16V. The output voltage is preset at 3.3V and can be adjusted down to 0.8V.

The AOZ1017AI-EVB circuit has features like current limit, short circuit protection, input under voltage lock out, internal soft start and thermal shut down. It operates at a fixed 500kHz switching frequency. The integrated internal MOSFET minimizes component count, board area and total cost.

The AOZ1019AI-EVB demonstrates the simple buck converter design. Only one resistor value change is needed for different output voltage designs. The AOZ1019AI-EVB also supports single layer board design.

## Features

- 4.5V to 16V operating input voltage range
- Output voltage preset to 3.3V, adjustable to as low as 0.8V
- 2A continuous output current
- Fixed 500kHz PWM operation
- Internal soft start
- Cycle-by-cycle current limit
- Short-circuit protection
- Thermal shutdown
- Enables single layer board design

## Applications

- Point of load DC/DC conversion
- PCIe graphics cards
- Set top boxes
- DVD drives and HDD
- LCD panels
- Cable modems
- Telecom/Networking/Datacom equipment

## Evaluation Board Schematic

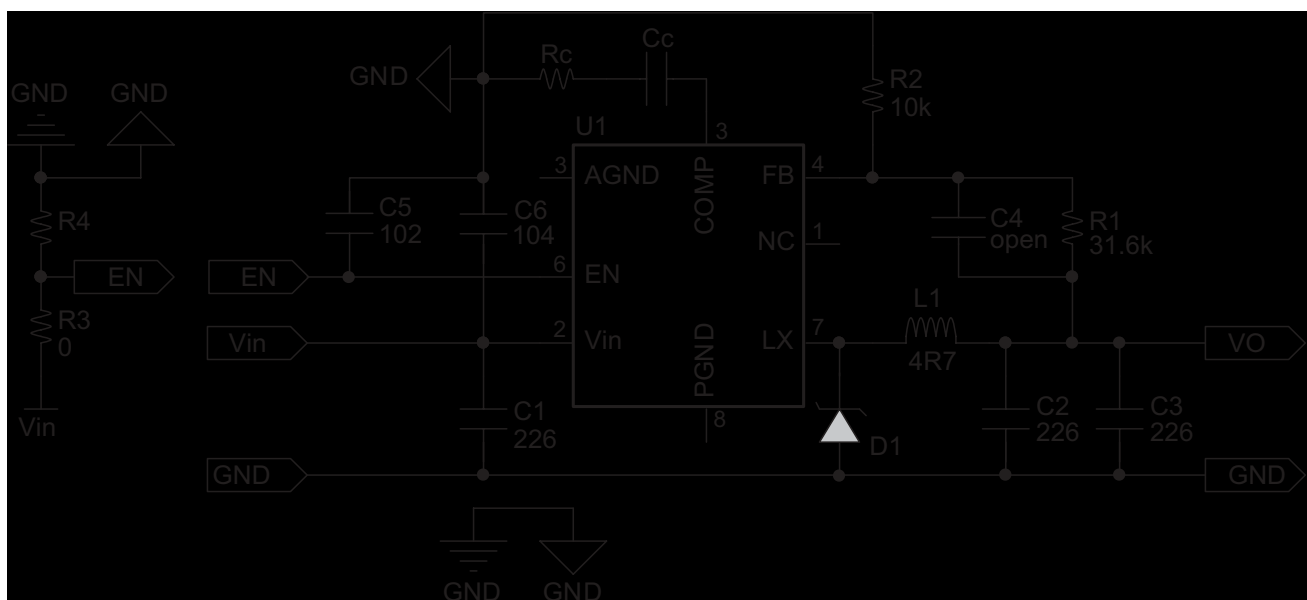

**Table 1. Component List**

Ref Designator	Part Number	Description	Manufacturer
C1, C2, C3	GRM32ER61E226KE15L	Cap, 22 $\mu$ F/25V, 1210, X5R, 10%	muRata
C4, Cp	Open	Cap, 0603	TDK, muRata
C5, Cc	C1608C0G1H102J	Cap, 1nF/50V, 0603, X7R 10%	TDK
	GRM188R71H102KA01D		muRata
C6	GRM188R71H104KA01D	Cap, 0.1 $\mu$ F/50V, 0603, X7R 10%	muRata
D1	MBRS230	Schottky Diode, SMB230	ON Semi
L	VLF10040T-4R7N5R4	Inductor, 4.7 $\mu$ H, 5.4A	muRata
R1	31.6k	Res, 31.6k, 0603, 1%	
R2	20k	Res, 20k, 0603, 1%	
R3	0	Res, 0, 0603	
R4	Open	Res, 0603, 5%	
Rc	20k	Res, 20k, 0603, 5%	
U1	AOZ1019AI	IC, MAX 2A, SO8	AOS

Output voltage is set by R1:  $R1 = R2 \cdot (V_{out} - 0.8) / 0.8$ . Table 2 below shows the value of R1 at typical output voltages.

**Table 2.**

Vout (V)	R1 (k $\Omega$ )	R2 (k $\Omega$ )
0.8	1	Open
1	2.49	10
1.2	4.99	10
1.5	8.66	10
1.8	12.7	10
2.5	21.5	10
3.3	31.6	10
5	52.3	10

## PCB Layout

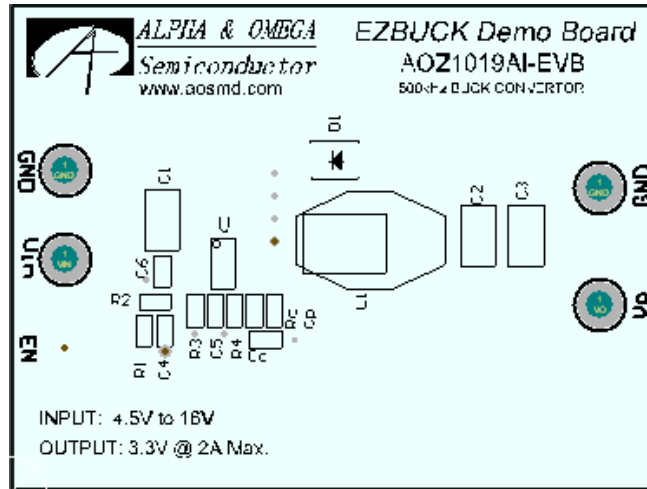

Figure 1. Top Silk Screen

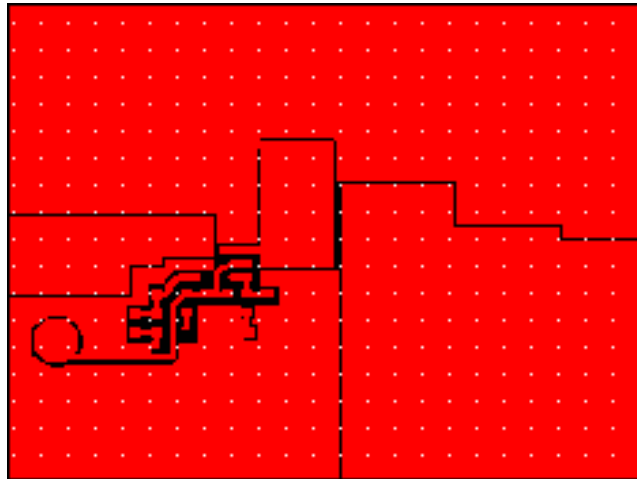

Figure 2. Top Layer

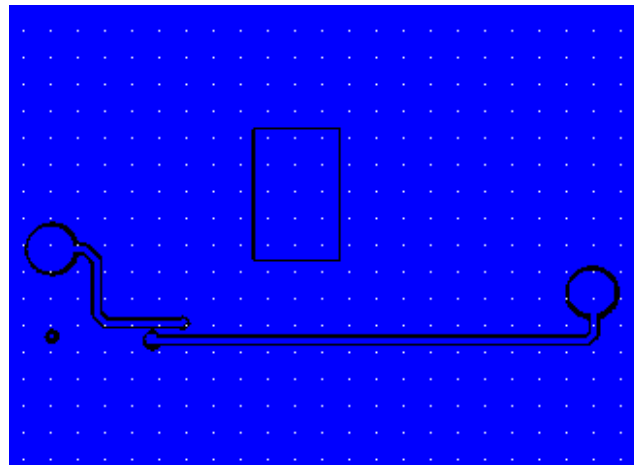

Figure 3. Bottom Layer

## Quick Start Guide

1. Connect the terminals of load to Vout and GND port.
2. Connect the DC power supply to Vin and GND port. Set DC power supply voltage to between 4.5V and 16V.
3. EN pin is connected to Vin via a 00hm resistor in the demo board. If a separate enable signal is desired, connect EN pin to any voltage source between 2.0V and 16V.
4. Measure input voltage at the Vin and GND ports to eliminate the effect of voltage drop on the wire between DC power supply and evaluation board.
5. Measure output voltage at the Vout and GND ports to eliminate the effect of voltage drop on the wire between load and evaluation board.
6. Use an oscilloscope to monitor the input ripple voltage across input capacitor C1.
7. Use an oscilloscope to monitor the output ripple voltage across output capacitor C3.

### Note:

When testing the ripple voltage, remove the cap of the voltage probe and touch the probe tip directly across the Vin or Vout and GND terminals, as shown in Figure 4.

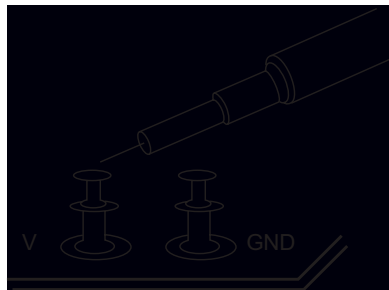

Figure 4. Voltage Ripple Test

**Alpha &Omega Semiconductor reserves the right to make changes at any time without notice.**

### LIFE SUPPORT POLICY

ALPHA & OMEGA SEMICONDUCTOR PRODUCTS ARE NOT AUTHORIZED FOR USE AS CRITICAL COMPONENTS IN LIFE SUPPORT DEVICES OR SYSTEMS.

As used herein:

1. Life support devices or systems are devices or systems which, (a) are intended for surgical implant into the body or (b) support or sustain life, and (c) whose failure to perform when properly used in accordance with instructions for use provided in the labeling, can be reasonably expected to result in a significant injury of the user.

2. A critical component in any component of a life support, device, or system whose failure to perform can be reasonably expected to cause the failure of the life support device or system, or to affect its safety or effectiveness.



SO8/SO8 EP Carrier Tape

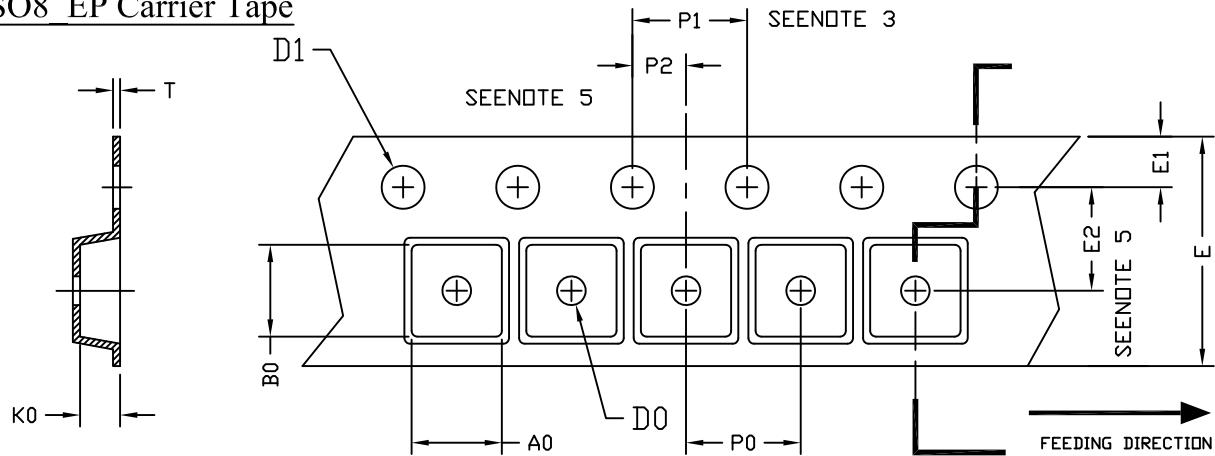

UNIT: MM

PACKAGE	A0	B0	K0	D0	D1	E	E1	E2	P0	P1	P2	T
SO-8 (12 mm)	6.40 ±0.10	5.20 ±0.10	2.10 ±0.10	1.60 ±0.10	1.50 +0.10	12.00 ±0.30	1.75 ±0.10	5.50 ±0.05	8.00 ±0.10	4.00 ±0.10	2.00 ±0.05	0.25 ±0.05

SO8/SO8 EP Reel

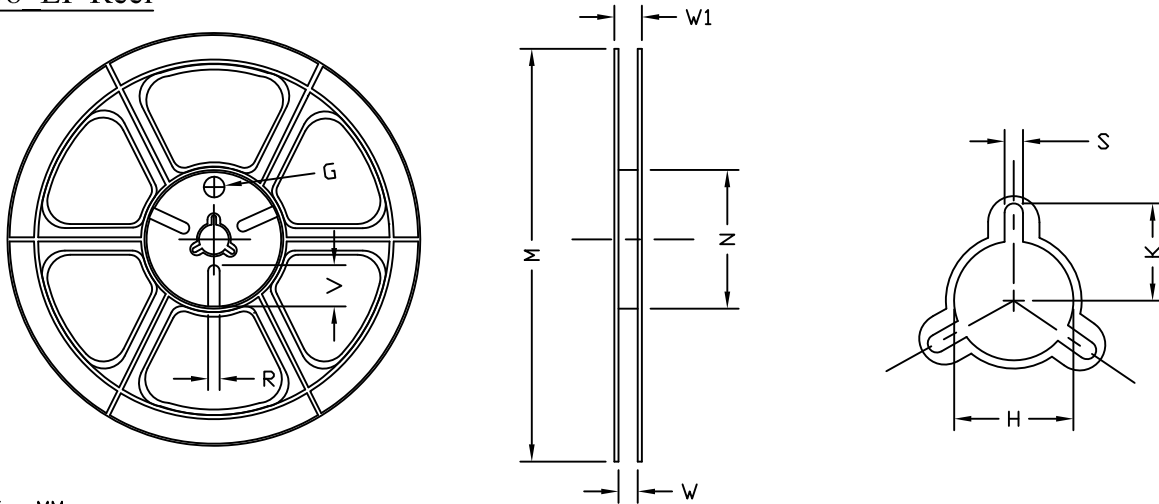

UNIT: MM

TAPE SIZE	REEL SIZE	M	N	W	W1	H	K	S	G	R	V
12 mm	ø330	ø330.00 ±0.50	ø97.00 ±0.10	13.00 ±0.30	17.40 ±1.00	ø13.00 +0.50 -0.20	10.60	2.00 ±0.50	---	---	---

SO8/SO8 EP Tape

Leader / Trailer  
& Orientation

Unit Per Reel:  
3000pcs

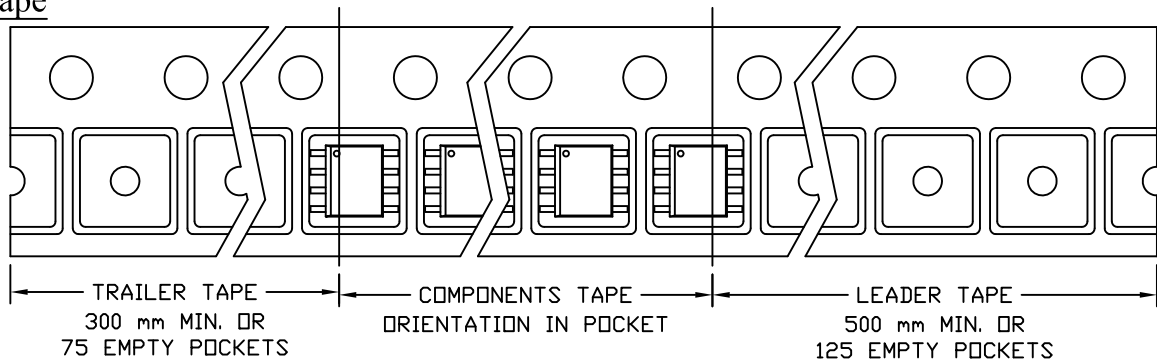



# ***AOS Semiconductor Product Reliability Report***

**AOZ1016AI/1017AI/1015AI/1019AI/1075AI/1081AI/  
1017DI/1094DI, rev 8**

**Plastic Encapsulated Device**

**ALPHA & OMEGA Semiconductor, Inc**

**495 Mercury Drive  
Sunnyvale, CA 94085  
U.S.**

**Tel: (408)830-9742  
[www.aosmd.com](http://www.aosmd.com)**

**October 10, 2008**

**This AOS product reliability report summarizes the qualification result for AOZ1016AI/1017AI/1015AI/1019AI/1075AI/1081AI/1017DI/1094DI.**

**Review of the electrical test results confirmed that AOZ1016AI/1017AI/1015AI/1019AI/1075AI/1081AI/1017DI/1094DI pass AOS quality and reliability requirements for final product and package release.**

## Table of Contents:

- I. Product Description
- II. Package and Die information
- III. Qualification Test Requirements
- IV. Qualification Tests Result
- V. Reliability Evaluation
- VI. Quality Assurance Information

## I. Product Description:

The AOZ1016AI is a high frequency 2A buck regulator with internal Schottky diode. AOZ1017AI is a 3A buck regulator and AOZ1017DI is a 4A buck regulator with external Schottky diode. AOZ1015AI is a 1.5A buck regulator with internal Schottky diode. AOZ1019AI is a 2A buck regulator with external Schottky diode. AOZ1075AI is a 1.2A buck regulator with internal Schottky diode. AOZ1081AI is a 1.8A buck regulator with internal Schottky diode. AOZ1094DI is a 5A buck regulator with external Schottky diode. These products are offered in a SO-8 or 5x4DFN-8 package and are rated over a -40°C to +85°C ambient temperature range.

<b>Absolute Maximum Ratings</b>	
Parameter	
Supply Voltage ( $V_{IN}$ )	18V
LX, EN to AGND	$V_{IN} + 0.3V$
FB, COMP to AGND	6V
Storage Temperature ( $T_s$ )	-65°C to +150°C
Operating Junction Temperature ( $T_J$ )	+150°C
<b>Thermal Characteristics</b>	
Package Thermal Resistance ( $R_{\theta JA}$ )	87°C/W

## II. Package and Die Information:

<b>Product ID</b>	AOZ1016AI/1017AI/1015AI/1019AI/1075AI/1081AI (AOZ1017DI/1094DI)
<b>Process</b>	0.5um 5/18V 2P2M process
<b>Package Type</b>	SO-8 (5x4DFN-8)
<b>Die Size</b>	1532 x 970 $\mu m^2$
<b>L/F material</b>	A194FH
<b>Die attach material</b>	84-3J epoxy (IC), 84-1LMISR4 (Discrete)
<b>Bond wire</b>	Au, 1-mil/2-mil
<b>Mold Material</b>	MP8000CH4 or G700HC



### III. Qualification Tests Requirements

- 2 lots of AOZ1016AI up to 500 hrs of Burn-In for new product final release.
- AOZ1015AI/1017AI/1019AI/1075AI are either same IC die as AOZ1016AI or minor metal change from AOZ1016AI and can be qualified by extension.
- 1 lot of AOZ1081AI up to 500 hrs of Burn-In for new product final release.
- 1 lot of AOZ1094DI 168 hrs of Burn-In for new product final release.
- Waive package stress test as lead-frames for AOZ1016AI/1017AI/1015AI are the same as AOZ1010AI and can be qual'd by extension. Lead-frame for AOZ1019AI is the same as AOZ1300AI and can be qual'd by extension.
- 2 lots of AOZ1014DIL, 250 temperature cycles and 96 hrs Pressure Pot for 5x4DFN-8 package release.

### IV. Qualification Tests Result

Test Item	Test Condition	Sample Size	Result	Comment
HTOL	Per JESD 22-A108-B $V_{IN} = 16V$ $T_j = 125^{\circ}C$	3 lots	pass	One AOZ1016AI lot (BD004), 120 units passed HTOL 500 hrs test. One AOZ1016AI lot (BD006), 60 units passed HTOL 500 hrs test. One AOZ1081AI lot (BA001), 60 units passed HTOL 500 hrs test. One AOZ1094DI lot (ZA8V11), 60 units passed HTOL 168 hrs test.
ESD (HBM, MM)	Per JESD 22-A114, JESD 22-A115-A, JESD 22-C101-C	3 units each mode	pass	3 units (BD008) AOZ1016AI passed 2KV HBM, 3 units (BD008) AOZ1016AI passed 200V MM. 3 units (BD011) AOZ1017AI passed 2KV HBM, 3 units (BD011) AOZ1017AI passed 200V MM. 3 units (BD004) AOZ1015AI passed 2KV HBM, 3 units (BD004) AOZ1015AI passed 200V MM. 3 units (BD003) AOZ1019AI passed 2KV HBM. 3 units (BD003) AOZ1019AI passed 200V MM. 3 units (BD002) AOZ1075AI passed 2KV HBM, 3 units (BD002) AOZ1075AI passed 200V MM. 3 units (BA001) AOZ1081AI passed 2KV HBM, 3 units (BA001) AOZ1081AI passed 200V MM. 3 units (ZA8T11) AOZ1017DI passed 2KV HBM, 3 units (ZA8T11) AOZ1017DI passed 200V MM. 3 units (ZA8V11) AOZ1094DI passed 2KV HBM, 3 units (ZA8V11) AOZ1094DI passed 200V MM.
Latch-up	Per JESD 78A	10 units	pass	5 units (BD003) AOZ1016AI passed latch-up test. 5 units (BD009) AOZ1017AI passed latch-up test.

SO-8 Package Qualification Data (qual by extension using AOZ1010AI data)				
Pre-Conditioning	Per JESD 22-A113 85C /85%RH, 3 cyc reflow@260 C	3 lots	pass	One AOZ1010A lot (FA7C8), 170 units and 2 other AOZ1010A lots (F857N and F856K), 144 units each, passed preconditioning.
HAST	130 +/- 2 C, 85%RH, 33.3 psi, at VCC min power dissipation	1 lot (60 /lot)	pass	One AOZ1010A lot (FA7C8), 60 units, passed. (Only one lot of data is available but there are many SO8 package qual. HAST data available from discrete FET for reference. (e.g. AO4403/4413/4912/4446/4610/4800/4818 etc.)
Temperature Cycle	-65 C to +150 C, air to air (2cyc/hr)	1 lot (55 /lot) 2 lots (77 /lot)	pass	One AOZ1010A lot (FA7C8), 55 units and 2 other AOZ1010A lots (F857N and F856K), 77 units each, passed TC 500 hrs.
Pressure Pot	121 C, 15+/-1 PSIG, RH= 100%	1 lot (55 /lot) 2 lots (77 /lot)	pass	One AOZ1010A lot (FA7C8), 55 units and 2 other AOZ1010A lots (F857N and F856K), 77 units each, passed PCT 96 hrs.
5x4DFN-8 Package Qualification Data				
Pre-Conditioning	Per JESD 22-A113 85C /85%RH, 3 cyc reflow@260 C	2 lots	pass	Two AOZ1014DIL lots (BA003, BA004), 82 units each, passed preconditioning.
Temperature Cycle	-65 C to +150 C, air to air (2cyc/hr)	2 lots	pass	Two AOZ1014DIL lots (BA003, BA004), 82 units each, passed 250 temperature cycles.
Pressure Pot	121 C, 15+/-1 PSIG, RH= 100%	2 lots	pass	Two AOZ1014DIL lots (BA003, BA004), 82 units each, passed 96 hrs Pressure Pot.

## V. Reliability Evaluation

The presentation of FIT rate for the individual product reliability is restricted by the actual burn-in sample size of the product. Failure Rate Determination is based on JEDEC Standard JESD 85. FIT means one failure per billion hours.

**FIT rate (per billion): 18**  
**MTBF = 6342 years**

The failure rate ( $\lambda$ ) is calculated as follows:

$$\lambda = (\chi^2_{[CL, (2f+2)]} / 2) \times (1/SS \times t \times AF) \dots \dots \dots [\text{eqn 1}] \quad \text{where}$$

CL = % of confidence level  
 f = number of failure  
 SS = sample size  
 t = stress time

Looking up the  $\chi^2/2$  table for zero failure (in HTOL) with 60% confidence, the value of  $(\chi^2_{[CL, (2f+2)]} / 2)$  is 0.92.



The Acceleration Factor (AF) is calculated from the following formula:

$$AF = \exp\left\{\left(\frac{E_a}{k}\right) \times \left[\frac{1}{T_0} - \frac{1}{T_s}\right]\right\}$$

where  $E_a$  = activation energy  
 $k$  = Boltzman constant  
 $T_0$  = operating  $T_J$   
 $T_s$  = stress  $T_J$

Taking the result of HTOL with SS (Total of 9 lots, 2 lots AOZ1010, 2 lots AOZ1014, 2 lots AOZ1016, 2 lots AOZ1020 and 1 lot AOZ1021) = 634 and  $t = 500$  hr. and assuming under typical operating environment,  $T_0 = 55^\circ\text{C}$ ;  $E_a = 0.7\text{eV}$  and  $T_s = 140^\circ\text{C}$

$$AF = \exp \left\{ (0.7/8.617 \times 10^{-5}) \times [1/(273+55) - 1/(273+140)] \right\} = 164$$

Substituting the values in equation 1, we have

$$\lambda = 0.92 \times \left\{ \frac{1}{(634 \times 500 \times 164)} \right\} = 1.77\text{E-}8 \text{ hr}^{-1} \text{ or } 18 \text{ FIT } [\text{MTBF} = (1000/\lambda) \text{ million hrs.}]$$

The calculation shows that under typical operating environment, the device failure rate is less than 18 FIT or an MTBF of over 55.56 million hours.

***The qualification test results confirm that AOZ1016AI/1017AI/1015AI/1019AI/1075AI/1081AI/1017DI/1094DI passed AOS quality and reliability requirements for product manufacturing release.***

## **VI. Quality Assurance Information**

Acceptable Quality Level for outgoing inspection: **0.1 %** for electrical and visual. Guaranteed Outgoing

Defect Rate: **< 50 ppm**

Quality Sample Plan: conform to **Mil-Std -105D**