

REVISIONS			
REV.	DESCRIPTION	DATE	APPROVED
A	INITIAL RELEASE	03/02/10	M.J.

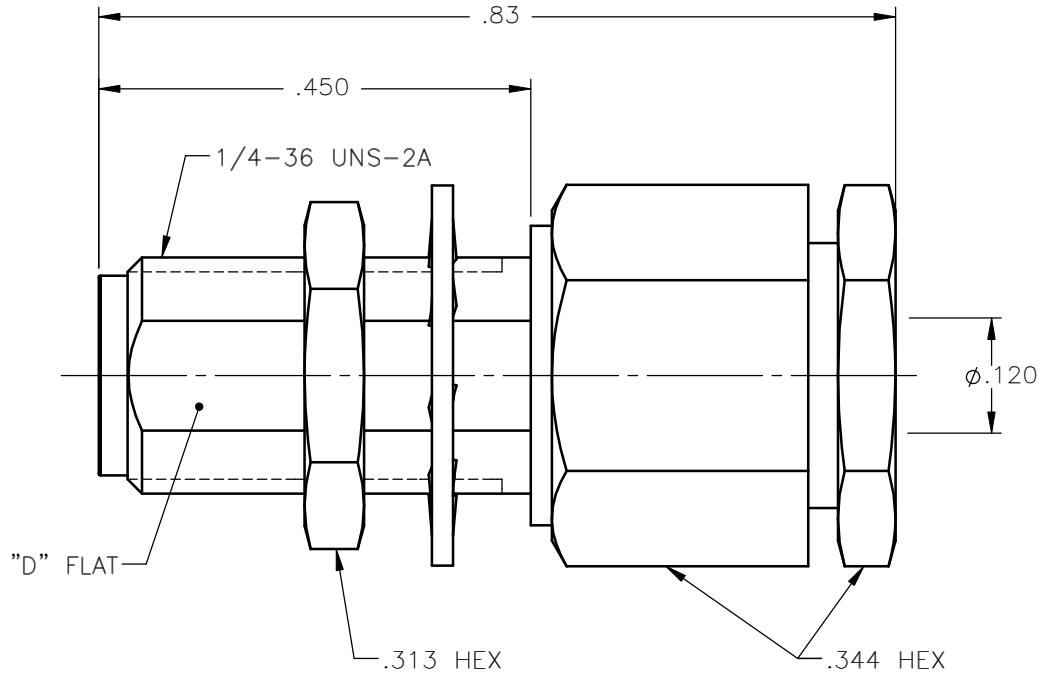

NOTES:

MATERIALS:

1. BODY & NUT = STAINLESS STEEL PER ASTM A582, ALLOY 303, CONDITION "A".
2. INSULATORS = VIRGIN WHITE TEFLON PER ASTM D1710, GRADE 1, TYPE I, CLASS "B".
3. CONTACT = BERYLLIUM COPPER PER ASTM B196, ALLOY C17300, TEMPER TD04.
4. LOCKWASHER = PHOSPHOR BRONZE PER ASTM B139, COPPER ALLOY C53400, TEMPER H04.
5. COMPRESSION NUT & SOLDER FERRULE = BRASS PER ASTM B16, ALLOY C36000, TEMPER H02.

FINISHES:

1. BODY & NUT = PASSIVATE PER QQ-P-35, TYPE VI.
2. CONTACT = GOLD PLATE PER MIL-G-45204, TYPE II, CLASS 1, GRADE C, OVER .00010 TO .00020 STRESS FREE SULFAMATE NICKEL PER QQ-N-290.
3. SOLDER FERRULE = GOLD PLATE PER MIL-G-45204, TYPE II, CLASS 0, GRADE C, OVER .00010 TO .00020 COPPER STRIKE PER MIL-C-14550.
4. COMPRESSION NUT & LOCKWASHER = NICKEL PLATE PER QQ-N-290, CLASS 1, GRADE G, EXCEPT .0001 TO .0002 THICK OVER .00005 TO .0001 THICK COPPER PER MIL-C-14550.

Property of Radiall Incorporated  
This document cannot be reproduced or communicated to a third party without prior written permission of RADIALL Incorporated.

UNLESS OTHERWISE SPECIFIED DIMENSIONS ARE IN INCHES TOLERANCES ON	DWN: M.J.	DATE: 03/02/10	 <b>APPLIED ENGINEERING PRODUCTS</b> 104 John W. Murphy Dr. New Haven, CT 06513 a RADIALL company			
	CHKD: A.D.M.	DATE: 03/02/10				
DECIMAL	ANGLE	APVD: J.M.	<b>SMA STRAIGHT BULKHEAD JACK          SOLDER-CLAMP TYPE          FOR S/R .086 &amp; SIMILAR CABLES</b>			
		DATE: 03/02/10				
REFERENCE:	MATERIALS & FINISHES: SEE NOTES		SIZE: A	FSCM NO.: 19505	DWG NO.: 9530-9593-010	REV: A
ORIGINATED: M.J. DATE: 03/02/10			SCALE: 5:1	THIRD ANGLE PROJECTION		SHEET 1 OF 1

9530-9593-010