

REVISION AD

NOTES:

1. Ⓢ REPRESENTS A CRITICAL DIMENSION.
2. ASSEMBLE GOLD PLATED END AS SHOWN.
3. TERMINAL PUSHOUT FORCE: 2 lbs BEFORE HEAT.
4. TERMINALS TO BE FLUSH TO .010[.25] BELOW TOP OF SHROUD.
5. TUBES ARE STANDARD PACKAGING
6. ORDERS WILL BE PACKAGED ACCORDING TO THE SAMTEC PACKAGING EFFICIENCY STANDARDS (SPES) FOUND ON WWW.SAMTEC.COM
7. ATTACH LABEL TO EACH REEL

DO NOT SCALE FROM THIS PRINT

HTST-1XX-01-XX-DV-XX-X-XX

No OF POSITIONS

-02 THRU -36
(PER ROW)

LEAD STYLE

-01: SURFACE MOUNT
(USE T-1S6-08-X-2)

PLATING SPECIFICATION

(VALUES GIVEN ARE IN MICRO-INCHES)

- T: MATTE TIN, CONTACT AND TAIL
- S: SELECTIVE, 30 Au / 50 Ni MIN ON CONTACT, MATTE TIN TAIL
- L: LIGHT SELECTIVE, 10 Au / 50 Ni MIN ON CONTACT, MATTE TIN TAIL
- H: HEAVY GOLD, 30 Au / 50 Ni MIN ON CONTACT, 3 Au / 50 Ni MIN ON TAIL
- F: FLASH SELECTIVE, 3 Au / 50 Ni MIN ON CONTACT, MATTE TIN TAIL
- TM: MATTE TIN CONTACT AND TAIL
- SM: SELECTIVE, 30 Au / 50 Ni MIN ON CONTACT, MATTE TIN TAIL
- FM: FLASH SELECTIVE, 3 Au / 50 Ni MIN ON CONTACT, MATTE TIN TAIL
- LM: LIGHT SELECTIVE, 10 Au / 50 Ni MIN ON CONTACT, MATTE TIN TAIL

PACKAGING OPTION

- BLANK: TUBES
- TR: TAPE & REEL
(POSITIONS -02 THRU -25 ONLY)
- FR: FULL REEL QTY TAPE & REEL

PICK & PLACE OPTION

- P: PICK & PLACE PAD
(USE PPP-22)

OPTION

- A: ALIGNMENT PIN (* ASO OPTION)
(SEE FIG. 3 SHT. 2)
- XX: POLARIZATION OPTION
(INDICATES POSITION OMITTED)

ROW SPECIFICATION

- DV: DOUBLE VERTICAL
(USE HTST-XX-D)

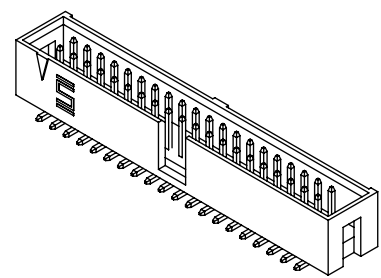
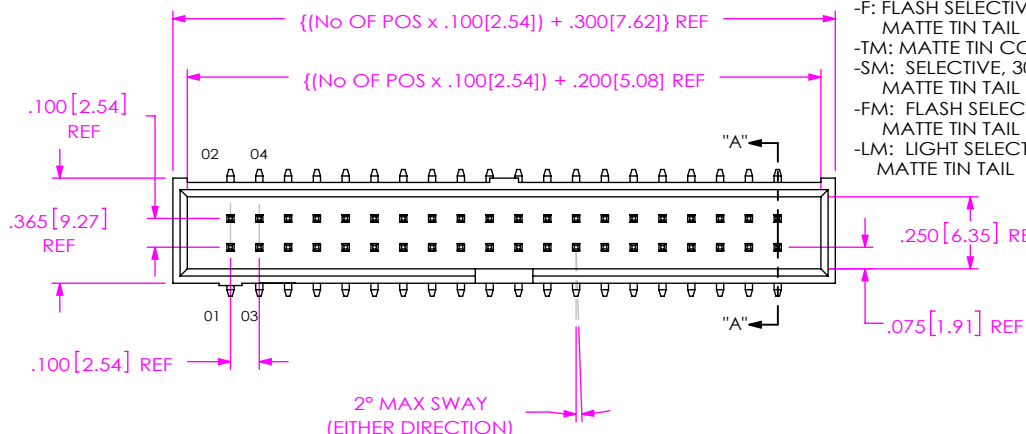

TABLE 1	
POSITIONS	COPLANARITY
-02 THRU -15	.0040[.102]
-16 THRU -36	.0060[.152]

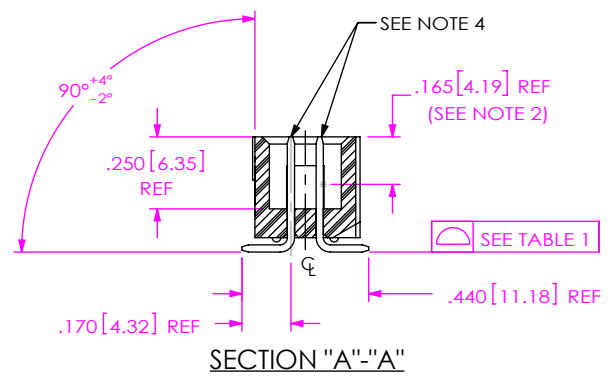
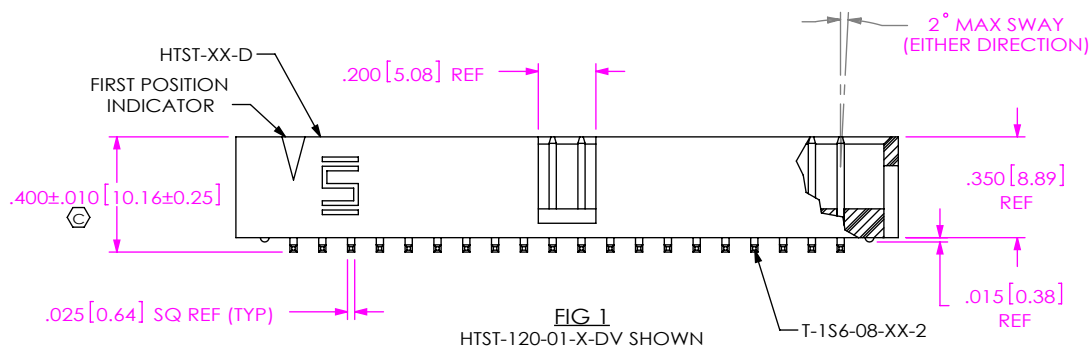
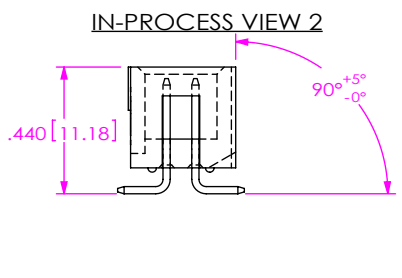
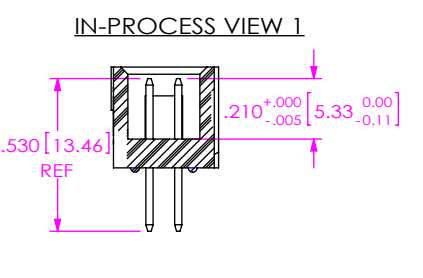

FIG 1
HTST-120-01-X-DV SHOWN



UNLESS OTHERWISE SPECIFIED, DIMENSIONS ARE IN INCHES. TOLERANCES ARE:
DECIMALS ANGLES
.XX: ±.01 [.3] 2°
.XXX: ±.005 [.13]
.XXXX: ±.0020 [.051]

PROPRIETARY NOTE
THIS DOCUMENT CONTAINS CONFIDENTIAL AND PROPRIETARY INFORMATION AND ALL DESIGN, MANUFACTURING, REPRODUCTION, USE, PATENT RIGHTS AND SALES RIGHTS ARE EXPRESSLY RESERVED BY SAMTEC, INC. THIS DOCUMENT SHALL NOT BE DISCLOSED, IN WHOLE OR PART, TO ANY UNAUTHORIZED PERSON OR ENTITY NOR REPRODUCED, TRANSFERRED OR INCORPORATED IN ANY OTHER PROJECT IN ANY MANNER WITHOUT THE EXPRESS WRITTEN CONSENT OF SAMTEC, INC.



520 PARK EAST BLVD, NEW ALBANY, IN 47150
PHONE: 812-944-6733 FAX: 812-948-5047
e-Mail: info@SAMTEC.com code: 55322

MATERIAL: DO NOT SCALE DRAWING SHEET SCALE: 1.5:1
INSULATOR: LCP, UL 94 V0; COLOR: NATURAL
TERMINAL: PHOS BRONZE

DESCRIPTION: HIGH TEMP TOP SHROUD
DWG. NO. HTST-1XX-01-XX-DV-XX-X-XX
BY: T. WERNE 07/11/2001 SHEET 1 OF 3

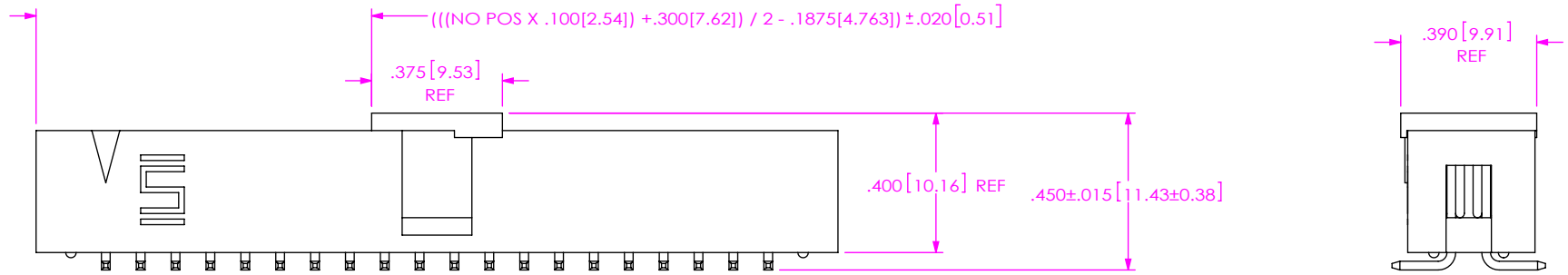

FIG 2
 -P: PICK & PLACE PAD OPTION
 (SAME AS FIG 1 UNLESS OTHERWISE STATED)

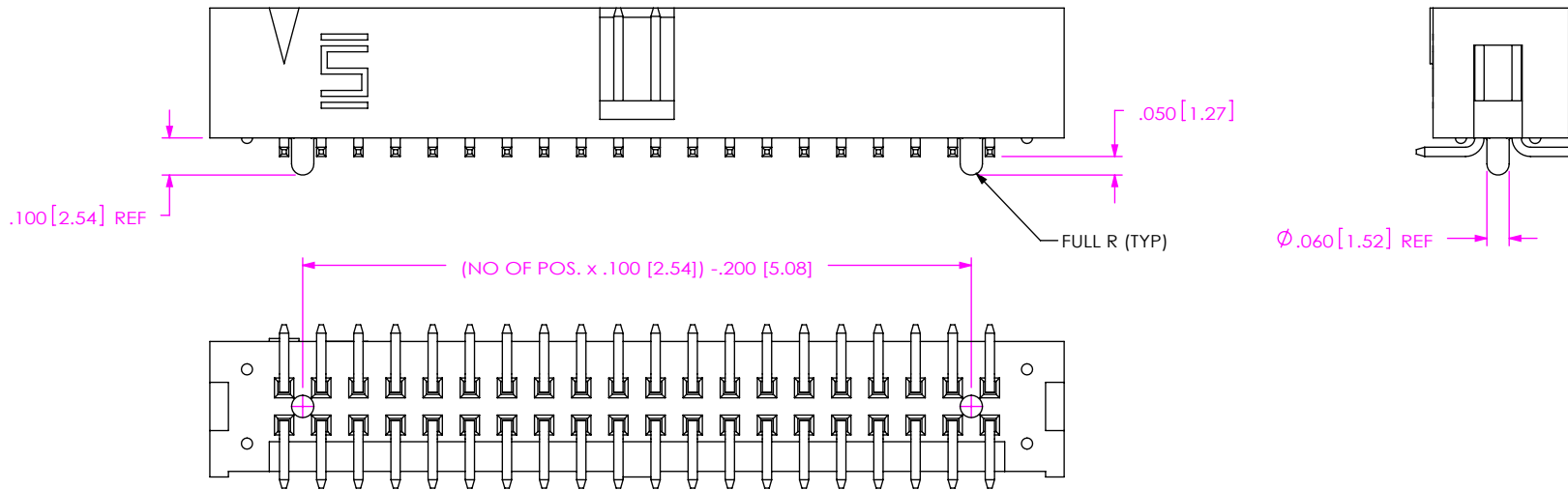

FIG 3
 -A: ALIGNMENT PIN OPTION
 (SAME AS FIG 1 UNLESS OTHERWISE STATED)

PROPRIETARY NOTE
 THIS DOCUMENT CONTAINS CONFIDENTIAL AND PROPRIETARY INFORMATION AND ALL DESIGN, MANUFACTURING, REPRODUCTION, USE, PATENT RIGHTS AND SALES RIGHTS ARE EXPRESSLY RESERVED BY SAMTEC, INC. THIS DOCUMENT SHALL NOT BE DISCLOSED, IN WHOLE OR PART, TO ANY UNAUTHORIZED PERSON OR ENTITY NOR REPRODUCED, TRANSFERRED OR INCORPORATED IN ANY OTHER PROJECT IN ANY MANNER WITHOUT THE EXPRESS WRITTEN CONSENT OF SAMTEC, INC.

DO NOT SCALE DRAWING

SHEET SCALE: 2:1



520 PARK EAST BLVD, NEW ALBANY, IN 47150
 PHONE: 812-944-6733 FAX: 812-948-5047
 e-Mail: info@SAMTEC.com code: 55322

DESCRIPTION:	HIGH TEMP TOP SHROUD
DWG. NO.	HTST-1XX-01-XX-DV-XX-X-XX
BY: T. WERNE	07/11/2001 SHEET 2 OF 3

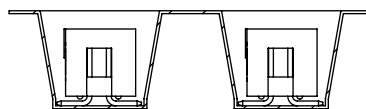
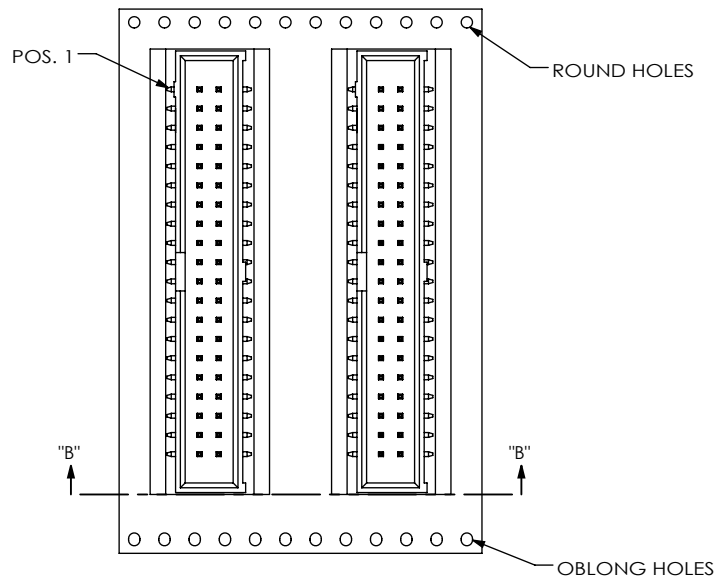

SECTION "B"- "B"
SCALE 1 : 1

USER DIRECTION OF REELING →
POCKET NOT DETAILED

TAPE & REEL VIEW

TUBE VIEW

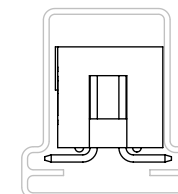

TUBE: PT-1-24-02-08
PLUG: TP-13

CRITICAL DIMENSION INSPECTION INSTRUCTION TABLE

ASSEMBLY OPERATION	IN-PROCESS INSPECTION
FILL	C5
FORM	C2
REPRESS	C1, C4

PROPRIETARY NOTE
 THIS DOCUMENT CONTAINS CONFIDENTIAL AND PROPRIETARY INFORMATION AND ALL DESIGN, MANUFACTURING, REPRODUCTION, USE, PATENT RIGHTS AND SALES RIGHTS ARE EXPRESSLY RESERVED BY SAMTEC, INC. THIS DOCUMENT SHALL NOT BE DISCLOSED, IN WHOLE OR PART, TO ANY UNAUTHORIZED PERSON OR ENTITY NOR REPRODUCED, TRANSFERRED OR INCORPORATED IN ANY OTHER PROJECT IN ANY MANNER WITHOUT THE EXPRESS WRITTEN CONSENT OF SAMTEC, INC.

DO NOT SCALE DRAWING

SHEET SCALE: 2:1



520 PARK EAST BLVD, NEW ALBANY, IN 47150
 PHONE: 812-944-6733 FAX: 812-948-5047
 e-Mail: info@SAMTEC.com code: 55322

DESCRIPTION: HIGH TEMP TOP SHROUD

DWG. NO. HTST-1XX-01-XX-DV-XX-X-XX

BY: T. WERNE 07/11/2001 SHEET 3 OF 3