



ANATECH ELECTRONICS INC
RF & Microwave Filters & Products

500 MHz LC Band Pass Filter

Part Number: AE500B6194



Electrical Specifications

Center Frequency: 500 MHz
Passband: 400-600 MHz
Insertion Loss: 3.0dB Max.
Return Loss: 14dB Min.
Rejection: $\geq 45\text{dB}$ @ 200 MHz
Rejection2: $\geq 45\text{dB}$ @ 800-4000 MHz

Mechanical

Mounting Method: Through Holes
Connector Type: SMA(F)
Dimensions: 4.0" X 1.25" x 0.75" .

Environmental

Operating Temperature: -25°C to $+70^{\circ}\text{C}$
Storage Temperature: -40°C to $+90^{\circ}\text{C}$
Shock: 10 G. 11ms
Vibration: 10 G. 5 to 200Hz

Outline Drawing:

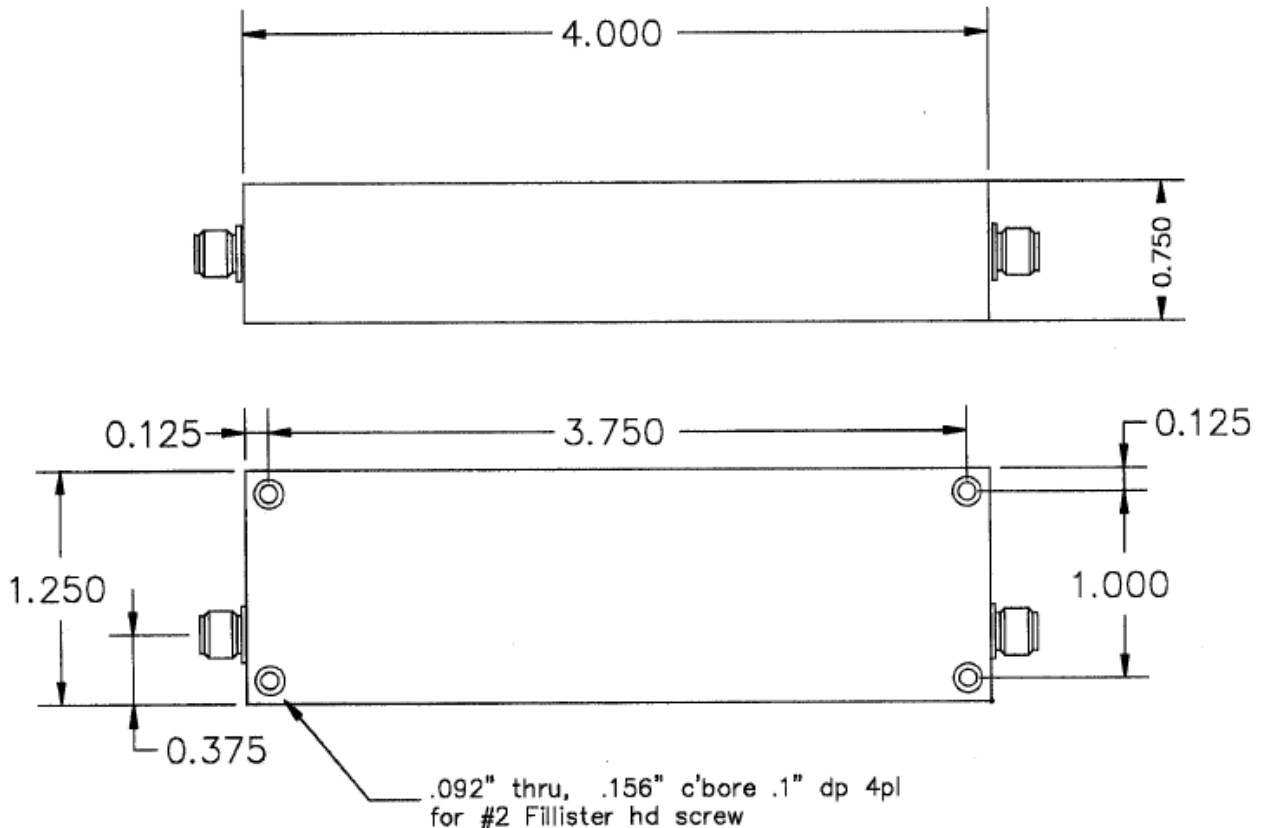



Response Plot:

