

Power Common Mode Chokes



ACMP-5045 Series

Request Samples



Check Inventory



5.0 x 4.8 x 4.5 mm
RoHS/RoHS II Compliant
MSL Level = 1

Features

- Commercial Grade
- PPAP ready and supported
- Excellent impedance characteristics
- Rated current up to 5A
- Low DCR

Applications

- DC power line common mode noise suppression.
- Switch Mode Power Supplies and regulators
- Variable Frequency Drives
- AC/DC power rectifiers

Electrical Specifications

Part Number	Impedance (Ω) @100MHz	DCR (m Ω)	Rated Current (A)	Rated Voltage (Vdc)	Insulation Resistance (M Ω)
	Typ.	Max	Typ.	Max	Min
ACMP-5045-191	190	20	5.0	50	10
ACMP-5045-351	350	40	2.0	50	10
ACMP-5045-501	500	50	1.8	50	10
ACMP-5045-801	800	50	1.5	50	10
ACMP-5045-102	1000	60	1.5	50	10
ACMP-5045-152	1500	100	1.0	50	10
ACMP-5045-302	3000	300	0.5	50	10

Rated Current is based on an Irms temperature rise of 40°C

Operating Temperature: -40°C to +125°C (Including self-heating)

Storage (in original packaging): <40°C, <60% RH

ACMP-5045 Series is RoHS Compliant and Pb free

Power Common Mode Chokes



ACMP-5045 Series

Request Samples



Check Inventory



5.0 x 4.8 x 4.5 mm
RoHS/RoHS II Compliant
MSL Level = 1

Electrical Specifications (Cont'd)

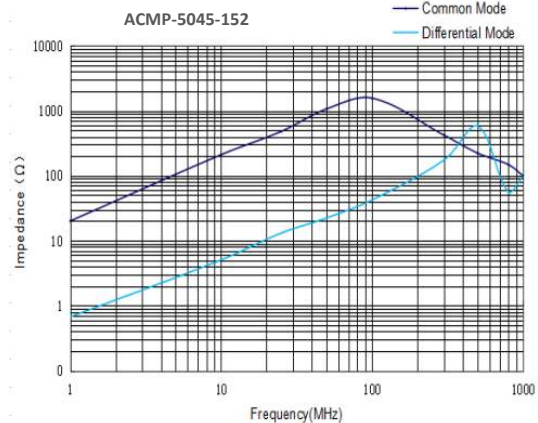
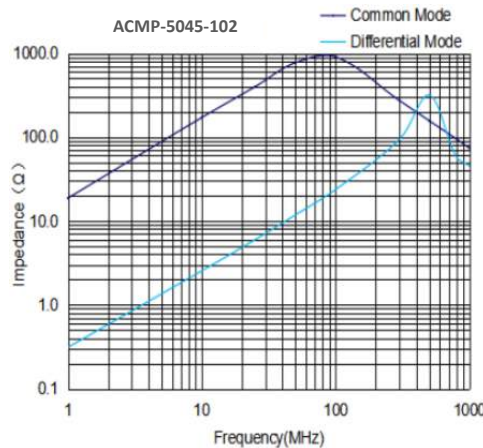
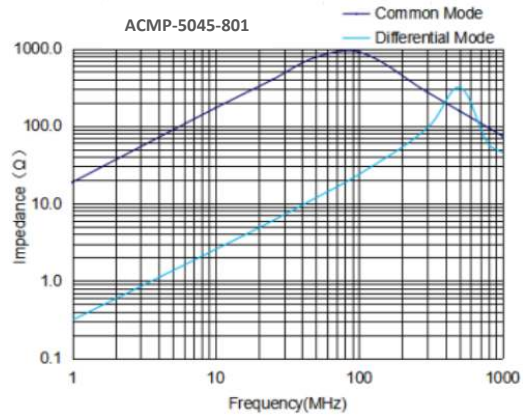
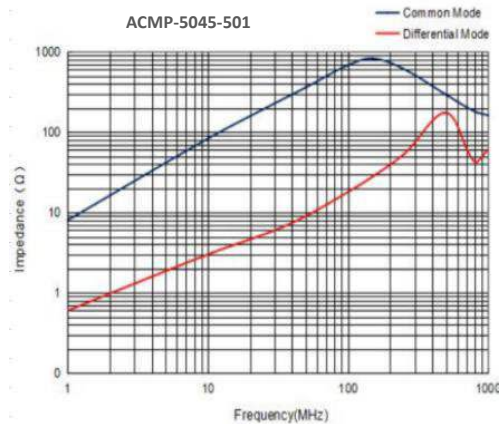
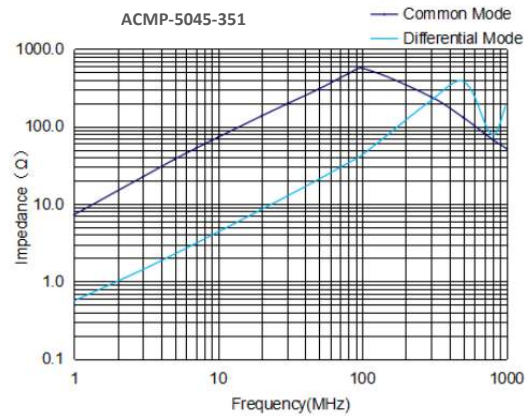
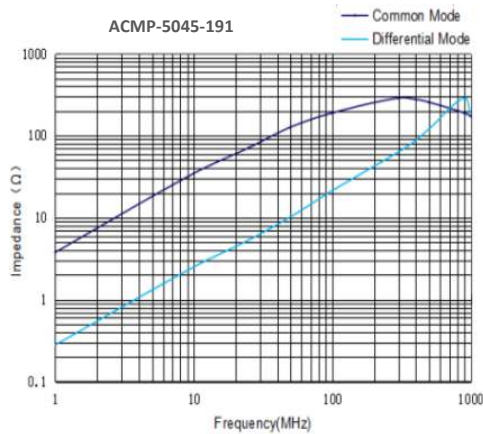

Power Common Mode Chokes



ACMP-5045 Series

Request Samples



Check Inventory



5.0 x 4.8 x 4.5 mm
RoHS/RoHS II Compliant
MSL Level = 1

Mechanical Specifications

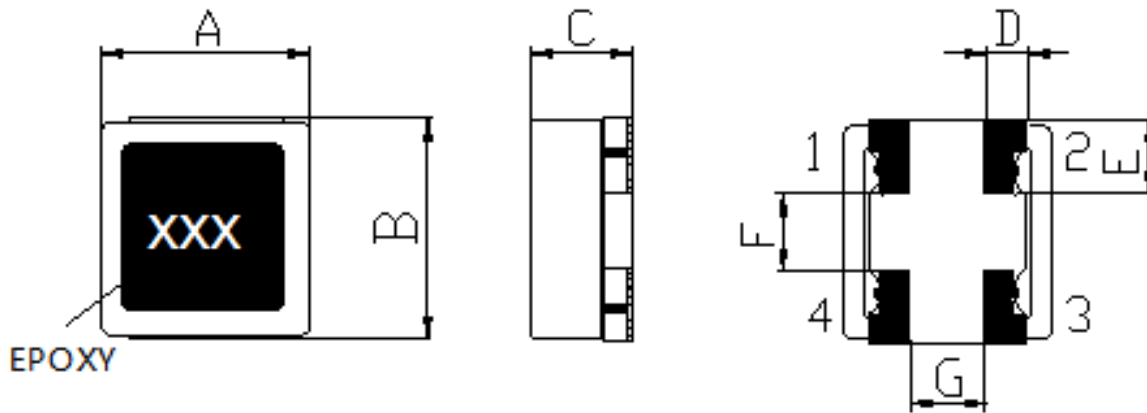

A	B	C	D	E	F	G
4.8 ± 0.3	5.0 ± 0.3	4.5 MAX	1.35 Ref.	1.9 Ref	1.2 Ref.	0.8 Ref.

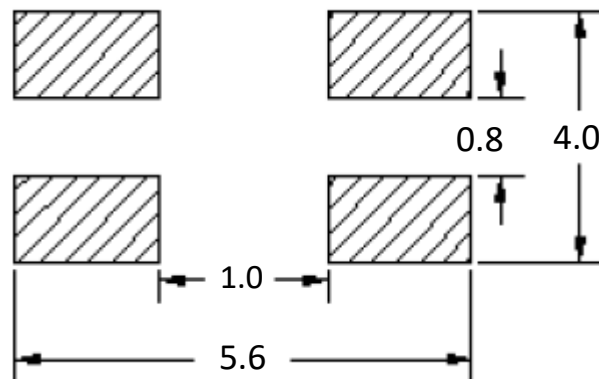

Recommended Layout

Dimensions: mm

Power Common Mode Chokes



ACMP-5045 Series

Request Samples



Check Inventory



5.0 x 4.8 x 4.5 mm
RoHS/RoHS II Compliant
 MSL Level = 1

Schematic

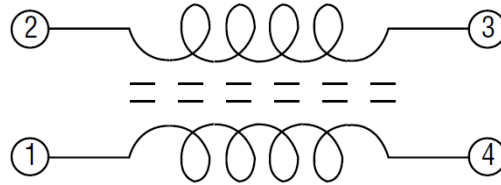

Materials

Description	Specification
Core	Ferrite core
Wire	Enameled copper wire
Base	Plastic
Adhesive	Epoxy resin
Terminal	Sn/Cu
Ink	White

Part Identification

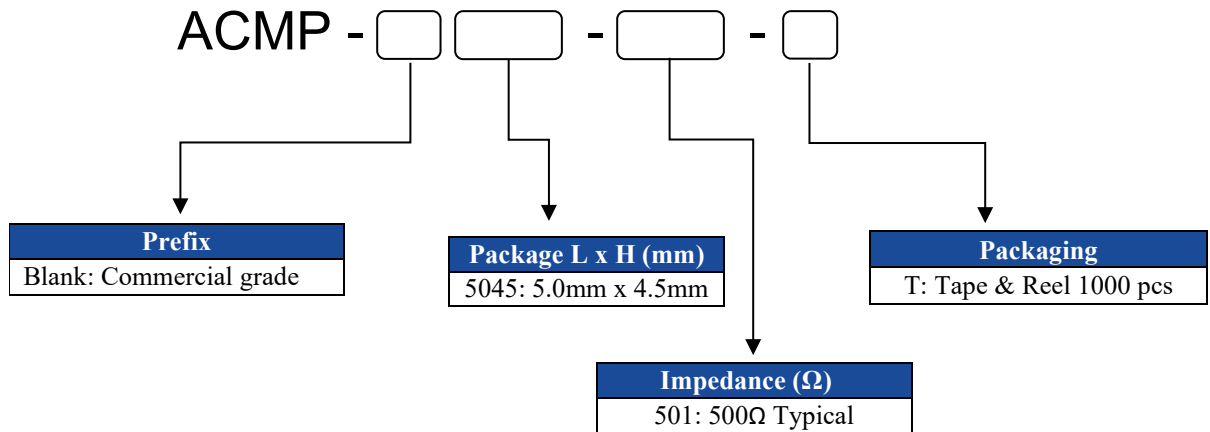

Power Common Mode Chokes



ACMP-5045 Series

Request Samples



Check Inventory



5.0 x 4.8 x 4.5 mm
RoHS/RoHS II Compliant
MSL Level = 1

Reflow Profile

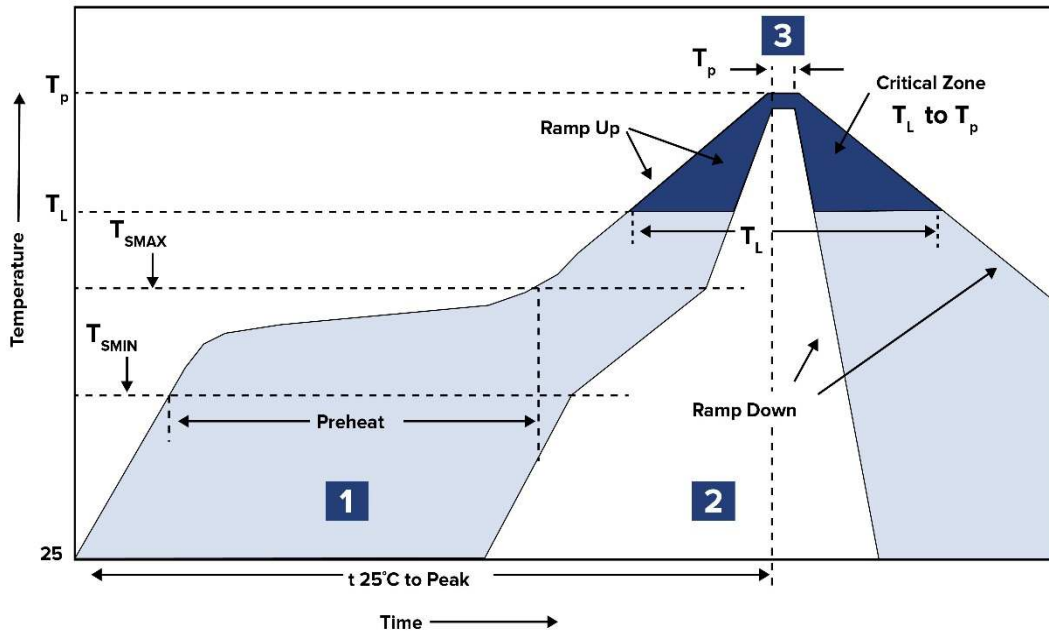

Zone	Description	Temperature	Times
1	Preheat	$T_{SMIN} \sim T_{SMAX}$ 150°C ~ 190°C	60 ~ 120 sec.
2	Reflow	T_L 240°C	20 ~ 40 sec.
3	Peak heat	T_P 255°C Max.	5 sec. Max

1~2 °C/Sec. Ramp

Power Common Mode Chokes



ACMP-5045 Series

Request Samples



Check Inventory



5.0 x 4.8 x 4.5 mm
RoHS/RoHS II Compliant
MSL Level = 1

Packing

Tape & Reel: 1000pcs/reel

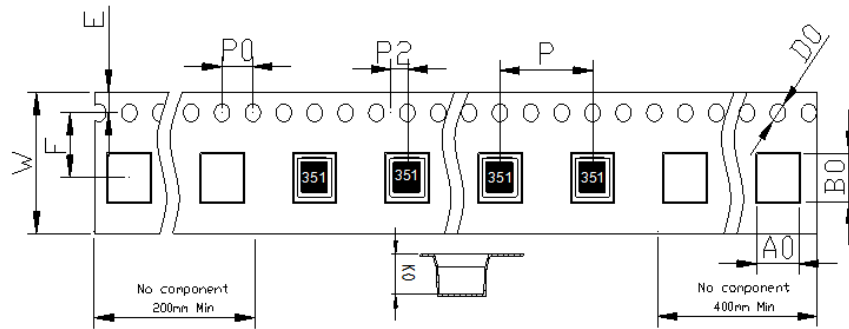
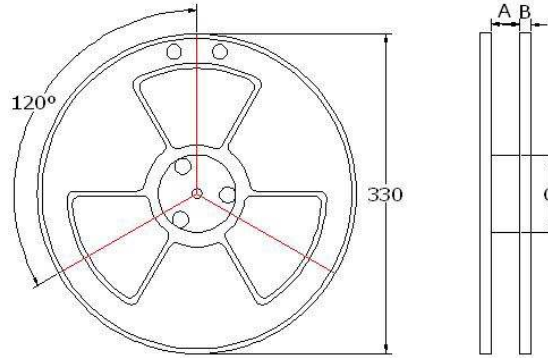

W	P	P0	P2	D0	E	F	A0	B0	K0
16 ± 0.30	12 ± 0.10	4.0 ± 0.10	2.0 ± 0.10	1.5 ± 0.10	1.75 ± 0.10	7.5 ± 0.10	5.4 ± 0.10	5.4 ± 0.10	4.7 ± 0.10

Dimensions: mm

ATTENTION: Abracon LLC's products are COTS – Commercial-Off-The-Shelf products; suitable for Commercial, Industrial and, where designated, Automotive Applications. Abracon's products are not specifically designed for Military, Aviation, Aerospace, Life-dependent Medical applications or any application requiring high reliability where component failure could result in loss of life and/or property. For applications requiring high reliability and/or presenting an extreme operating environment, written consent and authorization from Abracon LLC is required. Please contact Abracon LLC for more information.



5101 Hidden Creek Ln Spicewood TX 78669
 Phone: 512-371-6159 | Fax: 512-351-8858
 For terms and conditions of sales, please visit:
www.abracon.com

REVISION: IR 06-29-22

ABRACON IS
 ISO9001-2015
 CERTIFIED