

# SPECIFICATIONS

PARAMETERS	VALUES	UNITS
RESONANT FREQUENCY	6,500 ± 500	Hz
RESONANT IMPEDANCE (MAX)	500	Ohm
MAX INPUT VOLTAGE	30	Vp-p
CAPACITANCE @ 1KHZ	14,000 ±30%	pF
PLATE MATERIAL	BRASS	-
OPERATING TEMPERATURE	-20 ~ +60	°C
STORAGE TEMPERATURE	-20 ~ +70	°C

THIS DOCUMENT CONTAINS DATA PROPRIETARY TO PROJECTS UNLIMITED, INC. ANY USE OR REPRODUCTION, IN ANY FORM, WITHOUT PRIOR WRITTEN PERMISSION OF PROJECTS UNLIMITED, INC. IS PROHIBITED.  
©2003, Projects Unlimited Inc.

# REVISION HISTORY

LTR	DESCRIPTION	DATE	APPROVED
-	RELEASED FROM ENGINEERING	11/28/2001	
A	REVISED TO NEW TEMPLATE	9/4/03	R.W.
B	REVISED SPECIFICATIONS	1/12/2004	R.W.
C	REVISED DIMENSION SIZE AND STYLE	1/19/2006	B.R.
D	REVISED TO INVENTOR 3-D DRAWING TEMPLATE	8/11/2010	B.R.

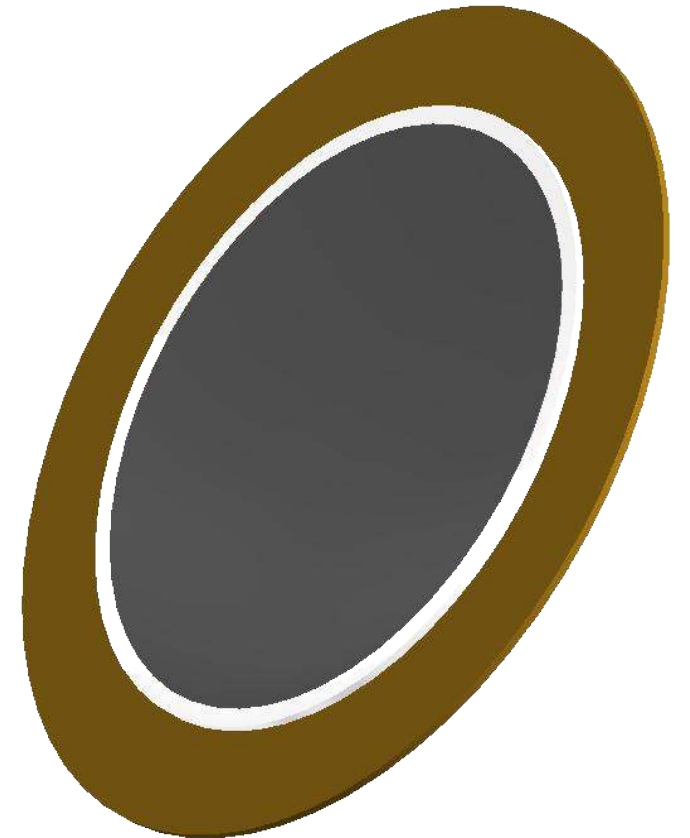
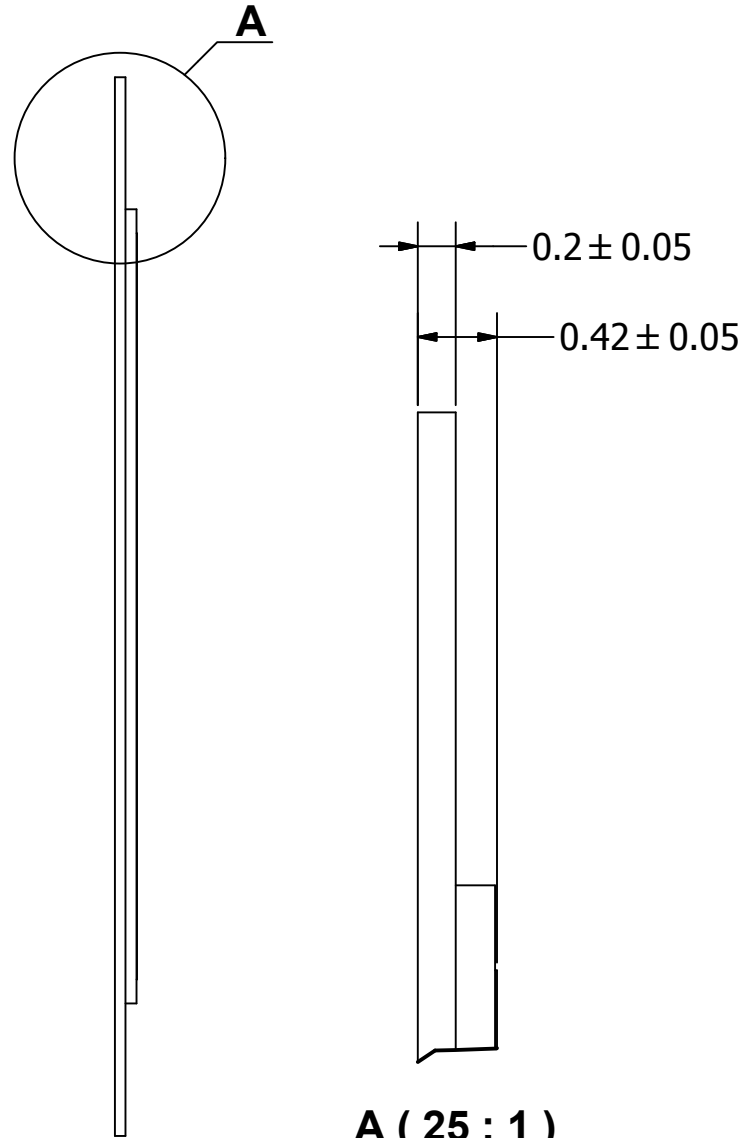
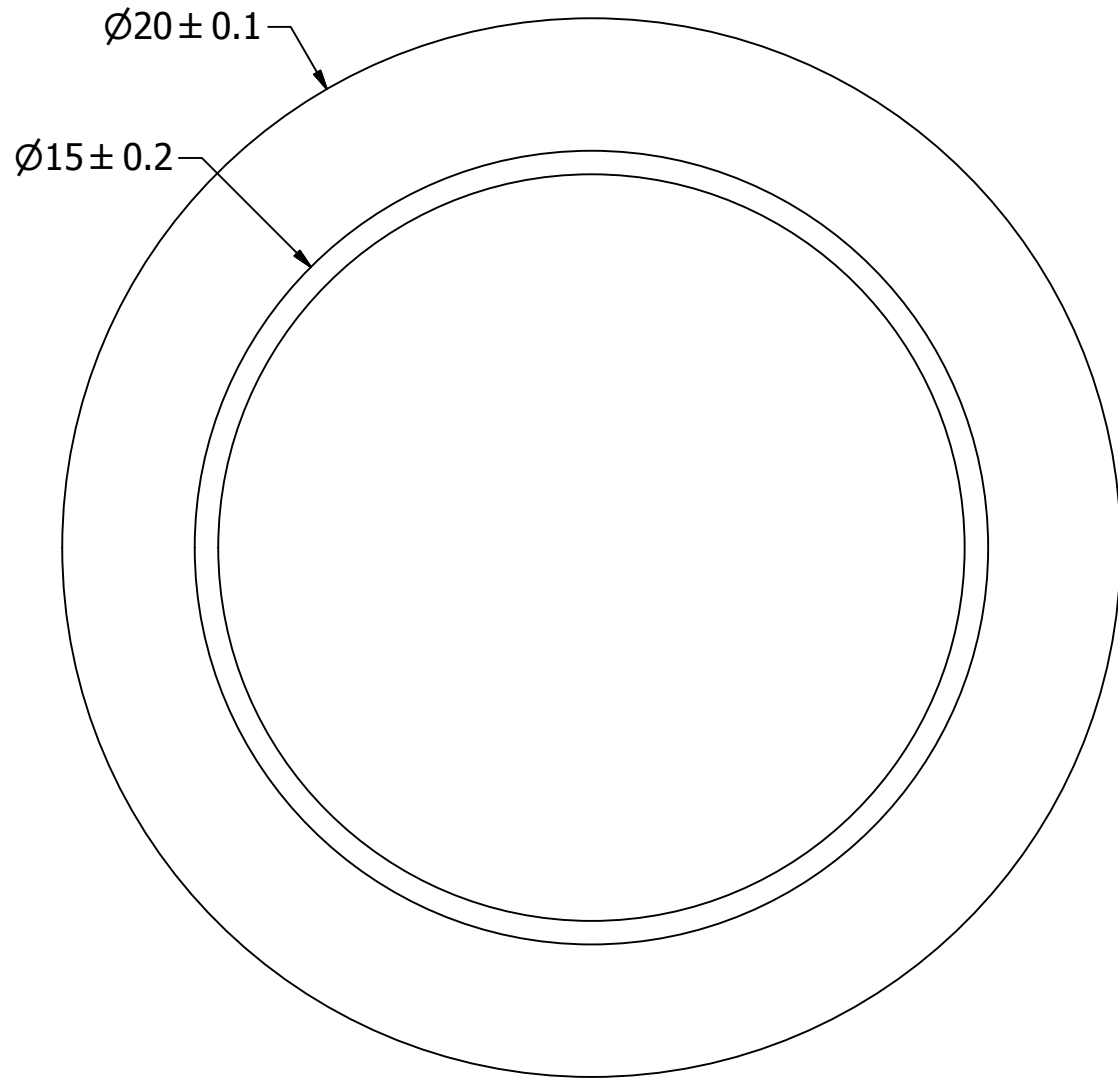

### NOTES:

1. ALL DIMENSIONS ARE IN MILLIMETERS.
2. SPECIFICATIONS SUBJECT TO CHANGE OR WITHDRAWL WITHOUT NOTICE.
3. THIS PART IS RoHS 2011/65/EU COMPLIANT.

UNLESS OTHERWISE SPECIFIED: DIMENSIONS ARE IN MILLIMETERS, TOLERANCES ARE ±0.5 AND ANGLES ARE ±3°.	SIZE <b>A3</b>	Designed by	Date	Checked by	Date	Approved by	Date	Drawn Date
		RABL	11/28/2001			S.J.	11/30/2001	8/11/2010
AB2065B.idw				<b>AB2065B</b>				
		Bender			Edition		Sheet	
					-		1 / 1	