

PAGE 1/3	ISSUE 15-05-15D	SERIES WQMA	PART NUMBER R123W177110
----------	-----------------	-------------	-------------------------

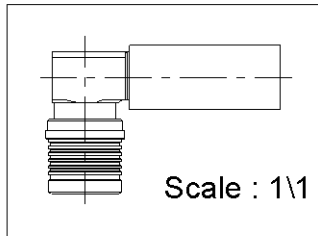

All dimensions are in mm.

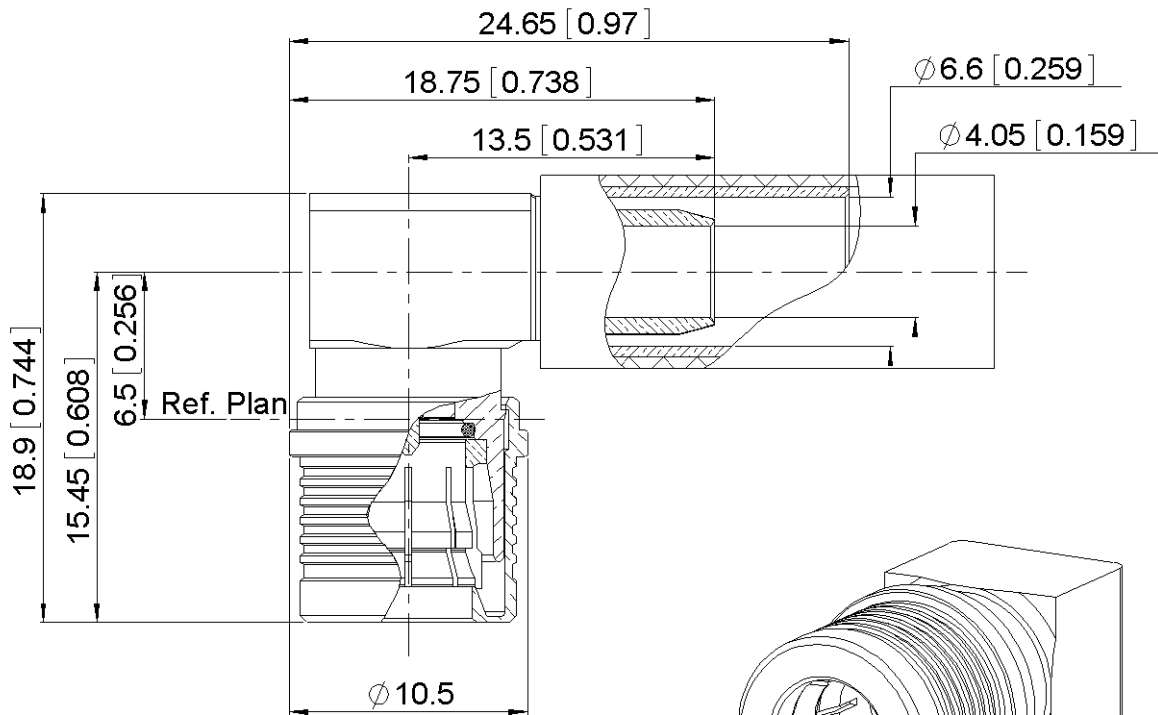
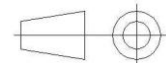

COMPONENTS	MATERIALS	PLATING (µm)
Body	BRASS	BBR
Center contact	BRASS	NPGR
Outer contact	BRONZE	BBR
Insulator	PTFE	
Gasket	SILICONE, AG COND, 70 DURO	
Others parts	BRASS.	BBR
-	-	-
-	-	-

PAGE 2/3	ISSUE 15-05-15D	SERIES WQMA	PART NUMBER R123W177110
----------	-----------------	-------------	-------------------------

PACKAGING

Standard	Unit	Other
100	Contact us	Contact us

ELECTRICAL CHARACTERISTICS

Impedance	50	Ω
Frequency	0-6	GHz
VSWR	TBD + 0.0000	x F(GHz) Maxi
Insertion loss	TBD	√F(GHz) dB Maxi
RF leakage	-(*80	- F(GHz)) dB Maxi
Voltage rating	335	Veff Maxi
Dielectric withstanding voltage	1000	Veff mini
Insulation resistance	5000	MΩ mini

MECHANICAL CHARACTERISTICS

Center contact retention		
Axial force – Mating End	18	N mini
Axial force – Opposite end	27	N mini
Torque	NA	N.cm mini
Recommended torque		
Mating	NA	N.cm
Panel nut	NA	N.cm
Clamp nut	NA	N.cm
A/F clamp nut	0.0000	mm
Mating life	100	Cycles mini
Weight	8.8500	g

ENVIRONMENTAL

Operating temperature	-40/+105	°C
Hermetic seal	NA	Atm.cm3/s
Panel leakage	NA	

SPECIFICATION

CABLE ASSEMBLY

Stripping	a	b	c	d	e	f
mm	3.3	6.7	15	0	11.7	0

Assembly instruction:

Recommended cable(s)
AEP-240FR
LMR 240

Characteristics indicated on this data sheet are those that can be achieved with the highest performance cable. Intrinsic limitations of the cable may diminish the performance of the assembly

Cable retention

- pull off	220	N mini
- torque	NA	N.cm

TOOLING

Part Number	Description	Hexagon
R282223000	CRIMPING TOOL	6.48
R282235013	CRIMPING DIES	
R282293000	CRIMPING TOOL M22520/5-01	6.48
R282761000	ASSEMBLY FIXTURE FOR	

OTHER CHARACTERISTICS

***Interface ingress protection: IP68(IEC60529) mated condition**
***RF leakage(interface):3<F<6GHz>70dB**

PAGE 3/3	ISSUE 15-05-15D	SERIES WQMA	PART NUMBER R123W177110
----------	-----------------	-------------	--------------------------------

COMPONENTS



STRIPPING DIMENSIONS

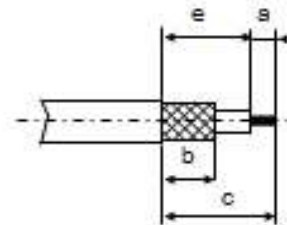

1

Slide the heatshrink sleeve onto the cable.
Slide the ferrule onto the cable.
Strip the cable.

4

Crimp the ferrule with crimping tool (see connector IUS).
Solder the inner conductor.

2

Fan the braid.

5

Mount the connector with crimping cable into the mounting tool.
Place the gasket and the cap into the body.

3

Push the connector body under the braid.
Slide the ferrule over the braid.

6

Press on the cap flush or slightly below the surface of the body assembly.
Slide the heatshrink sleeve over the ferrule and over the back of the body. Use if possible a pistol warm air. (Recommended temperature: 250 at 300°C)
Uniform heating on all the surface of the heatshrink sleeve.