

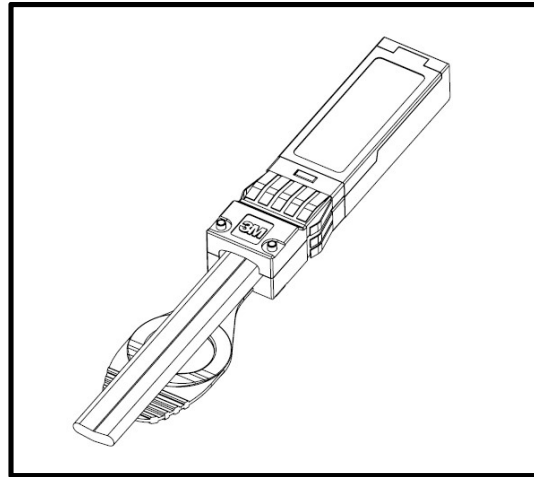

3M™ 25G SFP28 & 100G QSFP28 Direct Attach Copper Cable Assemblies, 1422, 1423, 9Q and 9S Series

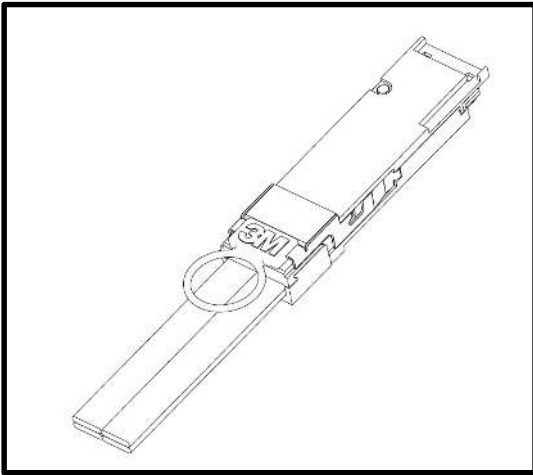

Scope

This document summarizes test methods, test conditions, and product performance requirements for 3M™ 25G SFP28 and 100G QSFP28 Direct Attach Copper Cable Assemblies including straight, Y, and breakout assembly configurations. 1422, 1423, 9Q, and 9S Series.

Reference Documents

Note: Unless otherwise specified, latest edition of the reference documents applies. In the event of conflict between requirements of the references and 3M specification, 3M specification shall take precedence.
Commercial standards, specifications and report

EIA-364
EIA TS-1000.01
SFF-8436, SFF-8661
SFF-8432, SFF-8083

3M™ 100G Direct Attach Copper Cable Assemblies		
Literature Code	Series	Document Title
78-5100-2664-0	1422/1423	Customer Drawing, 3M™ 25G SFP28 Direct Attach Copper Cable Assemblies, 1422/1423 Series
78-5100-2672-3	9Q	Customer Drawing, 3M™ 100G QSFP28 Direct Attach Copper Cable Assemblies, 9Q Series
78-5100-2684-8	9S	Customer Drawing, 3M™ 100G QSFP28 to 2x QSFP28 Direct Attach Copper Cable Assemblies, 9S Series
78-5100-2679-8	9S	Customer Drawing, 3M™ 100G QSFP28 to 4x SFP28 Direct Attach Copper Cable Assemblies, 9S Series

3M™ 25G & 100G Direct Attach Copper Cable Assemblies, 1422, 1423, 9Q and 9S Series

Performance Testing

Unless otherwise specified, all tests shall be performed on SFP28/QSFP28 headers mated to SFP28/QSFP28 sockets with 3M Twinax cable at conditions per EIA-364. Unless otherwise specified, all values and limits are typical of those obtained by qualification testing of the subject product. All specifications are subject to revision and change without notice from 3M.

Ratings

3M™ 25G/100G SFP28/QSFP28 Direct Attach Copper Cable Assemblies, 142/9Q/9S Series	
Feature	Value
Impedance	100ohms
Operating Temperature	0°C to 70°C
Storage Temperature	-20°C to 85°C
Humidity	0% to 80% RH
Halogen Free – CL2 cable only	CL2 cable option only. Does not include connector ends. UL has tested cables to be Halogen Free per UL2885. UL PLCC file E118773.

Materials

3M™ 25G/100G SFP28/QSFP28 Direct Attach Copper Cable Assemblies, 142/9Q/9S Series		
	Component	Material
Connector	Shell	Die Cast Zinc
Connector	Pull Tab	Thermoplastic
Connector	Latch	Stainless Steel
Connector	Spring	Stainless Steel
Connector	Paddle Card	Flame Retardant PCB with 0.73um (30u”) Au over 1.27um (50u”) Ni min mating pad finish.
Cable	Primary Cable	100 Ohm differential PO insulators
Cable	EMI Shield	Copper Foil laminate
Cable	Jacket	Flame retardant PVC or Halogen Free material. See Technical Specification for details and ratings.

3M™ 25G & 100G Direct Attach Copper Cable Assemblies, 1422, 1423, 9Q and 9S Series

Regulatory Compliance

For regulatory information, visit 3M.com/regs or contact your 3M representative. See customer drawings for regulatory specifics on each connector.

Electrical

Note: The following technical information and data should be considered representative or typical only and should not be used for specification purposes.

3M™ 25G/100G SFP28/QSFP28 Direct Attach Copper Cable Assemblies, 142/9Q/9S Series				
Description or Parameter	Units	Values and Limits	Requirement or Conditions	Test Standard or Method
Dielectric Withstanding Voltage	V DC	300	EIA-364-20, Method B Subject a voltage of 300 VDC for 1 minute at sea level between adjacent contacts of mated and unmated connector assemblies.	EIA-364-20B
Insulation Resistance	Mega ohms	>1000	Measured between adjacent and opposing contacts with 300 V applied for 1 minute.	EIA-364-21C
Impedance	ohm	100+/-5	Measurement of a differential pair	IEEE8023bj
Insertion Loss	db	> -22.48	SDD21 @ 12.89Ghz	IEEE8023bj
Diff to Common Mode Conv. Loss	db	Formula	SCD21 – SDD21	IEEE8023bj

3M™ 25G & 100G Direct Attach Copper Cable Assemblies, 1422, 1423, 9Q and 9S Series

Mechanical

Note: The following technical information and data should be considered representative or typical only and should not be used for specification purposes.

3M™ 25G/100G SFP28/QSFP28 Direct Attach Copper Cable Assemblies, 142/9Q/9S Series				
Description or Parameter	Units	Values and Limits	Requirement or Conditions	Test Standard or Method
QSFP28 Mating force	Newtons	40N Max.	Refer to SFF8436 Spec. Tested without latch feature	EIA-364-13
QSFP28 Unmating force	Newtons	30N Max.	Refer to SFF8436 Spec. Tested without latch feature	EIA-364-13
SFP28 Mating force	Newtons	18N Max.	Refer to SFF8432 Spec. Tested without latch feature	EIA-364-13
SFP28 Unmating force	Newtons	12.5N Max.	Refer to SFF8432 Spec. Tested without latch feature	EIA-364-13
Latched plug retention force	Newtons	90N Min.	Refer to SFF8432 Spec. Tested with latch feature	EIA-364-98
Shock	G Sec Pulse	50 11ms half sine	Mated connectors shall exhibit no damage. No significant change in SDD21 or SCD21-SDD21.	EIA-364-27B Condition A
Vibration	G	3.10	3.10G RMS between 20 and 500 Hz at 15 minutes in each of 3 mutually perpendicular directions. No damage. No discontinuity longer than 1µsec allowed. No significant change in SDD21 or SCD21-SDD21.	EIA-364-28 Condition VII D
Durability (preconditioning)	NA	Nil	Perform 50 unplug/plug cycles. No evidence of physical damage.	EIA-364-09
Durability	NA	Nil	Perform 250 unplug/plug cycles. No evidence of physical damage.	EIA-364-09
Reseating	NA	Nil	Perform 3 unplug/plug cycles.	EIA-364-09

3M™ 25G & 100G Direct Attach Copper Cable Assemblies, 1422, 1423, 9Q and 9S Series

Environmental

Note: The following technical information and data should be considered representative or typical only and should not be used for specification purposes.

3M™ 25G/100G SFP28/QSFP28 Direct Attach Copper Cable Assemblies, 142/9Q/9S Series				
Description or Parameter	Units	Values and Limits	Requirement or Conditions	Test Standard or Method
Temperature Life (Thermal Aging)	Degrees C Hours	85 250	No physical abnormalities. No significant change in SDD21 or SCD21-SDD21.	EIA-364-17B Method A Condition 3B
Thermal Shock	Degrees C Cycles	-55 & 85 10	No physical abnormalities. No significant change in SDD21 or SCD21-SDD21.	EIA-364-32A Condition I
Humidity-Temperature Cycling	Degrees C % RH Cycles	65 to 25 80 to 50% 24	1 cycle - 25°C, 80%RH to 65°C, 50RH to 25°C 80%. Ramp: 0.5 hour, Dwell: 1.0 hour. No significant change in SDD21 or SCD21-SDD21	EIA-364-31B Condition B Method III 24 cycles.
Corrosivity of Contacts (Humidity)	Degrees C % RH Hours	40 90-96% 336	Steady stage Humidity. No significant change in SDD21 or SCD21-SDD21	EIA-364-113A Condition I

Qualification Test Groups and Sequenced Tests

Note: The following technical information and data should be considered representative or typical only and should not be used for specification purposes.

3M™ 25G/100G SFP28/QSFP28 Direct Attach Copper Cable Assemblies, 142/9Q/9S Series					
Test Description	EIA 364 TP No.	Test Group			
		1	2	3	4
		Test Sequence			
Visual	18	0,5	0,17	0, 7	0,10
SI (SDD21, SCD21-SDD21)		1,4	1,6	1,4,6	1,9
Durability (preconditioning)	09	2	2		
Durability (full)	09				5
Reseating	09		5		
Mechanical Shock	27			2	
Mechanical Vibration	28			3	
Temperature Life	17	3			
Humidity Temperature Cycling	31		4		
Thermal Shock	32		3		
Humidity, Corrosivity of Contacts				5	
Dielectric Withstand Voltage	20				2,6
Mating Force	13				3,7
Unmating Force	13				4,8
Latched Plug Retention Force	98				11

3M™ 25G & 100G Direct Attach Copper Cable Assemblies, 1422, 1423, 9Q and 9S Series

For regulatory information, visit [3M.com/regs](https://www.3m.com/regs) or contact your 3M representative.

Technical Information: The technical information, recommendations and other statements contained in this document are based upon tests or experience that 3M believes are reliable, but the accuracy or completeness of such information is not guaranteed.

Warranty, Limited Remedy, and Disclaimer: Unless an additional warranty is specifically stated on the applicable 3M product packaging or product literature, 3M warrants that each 3M product meets the applicable 3M product specification at the time 3M ships the product. 3M MAKES NO OTHER WARRANTIES OR CONDITIONS, EXPRESS OR IMPLIED, INCLUDING, BUT NOT LIMITED TO, ANY IMPLIED WARRANTY OR CONDITION OF MERCHANTABILITY OR FITNESS FOR A PARTICULAR PURPOSE OR ANY IMPLIED WARRANTY OR CONDITION ARISING OUT OF A COURSE OF DEALING, CUSTOM OR USAGE OF TRADE. If the 3M Product does not conform to this warranty, then the sole and exclusive remedy is, at 3M's option, replacement of the 3M product or refund of the purchase price.

Product Use: Many factors beyond 3M's control and uniquely within user's knowledge and control can affect the use and performance of a 3M product in a particular application. Given the variety of factors that can affect the use and performance of a 3M product, user is solely responsible for evaluating the 3M product and determining whether it is fit for a particular purpose and suitable for user's method of application.

Limitation of Liability: Except where prohibited by law, 3M will not be liable for any loss or damage arising from the 3M product, whether direct, indirect, special, incidental or consequential, regardless of the legal theory asserted, including warranty, contract, negligence or strict liability.



3M Electronics Materials Solutions Division
Interconnect Products
13011 McCallen Pass Bldg. C
Austin, TX 78753
www.3m.com/interconnect

3M is a trademark of 3M Company.
Please recycle.
©3M 2019. All rights reserved.
78-5102-0262-1, Rev B