

- ① THE NOTED DIMENSIONS APPLY AT THE INTERSECTION OF THE POST AND HOUSING
- ② POSTS: GOLD FLASH OVER PALLADIUM-NICKEL PLATE, .000030 MIN TOTAL ON THE MATING SURFACES, .000100 MIN TIN-LEAD PLATE ON THE SOLDER-TAILS, .000050 MIN NICKEL UNDERPLATE ON THE ENTIRE POST.  
-OR-  
.000030 MIN GOLD PLATE ON THE MATING SURFACES, .000100 MIN TIN-LEAD PLATE ON THE SOLDER-TAILS, .000050 MIN NICKEL UNDERPLATE ON THE ENTIRE POST.
- ③ DOUBLE BAR POLARIZATION
- ④ CENTER POLARIZATION SLOT
- ⑤ FOR 10 POSN ASSEMBLY, SLOT OMITTED WHERE INDICATED
- ⑥ NUMBER 1 POSITION INDICATOR.
- ⑦ OPTIONAL AMP IDENTIFICATION NUMBER (DATE CODE). LOCATION APPROXIMATELY WHERE SHOWN.

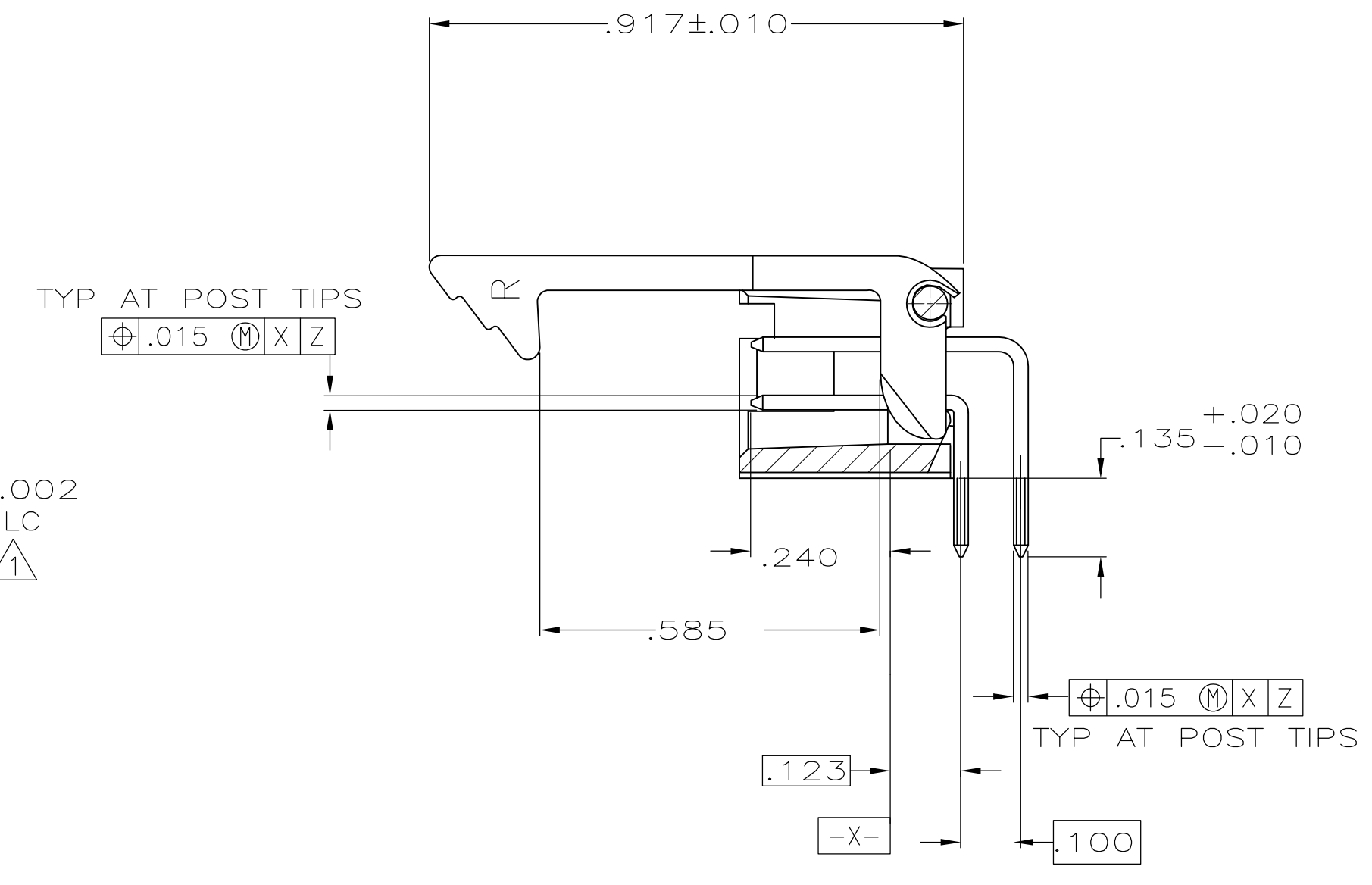

SECTION X-X

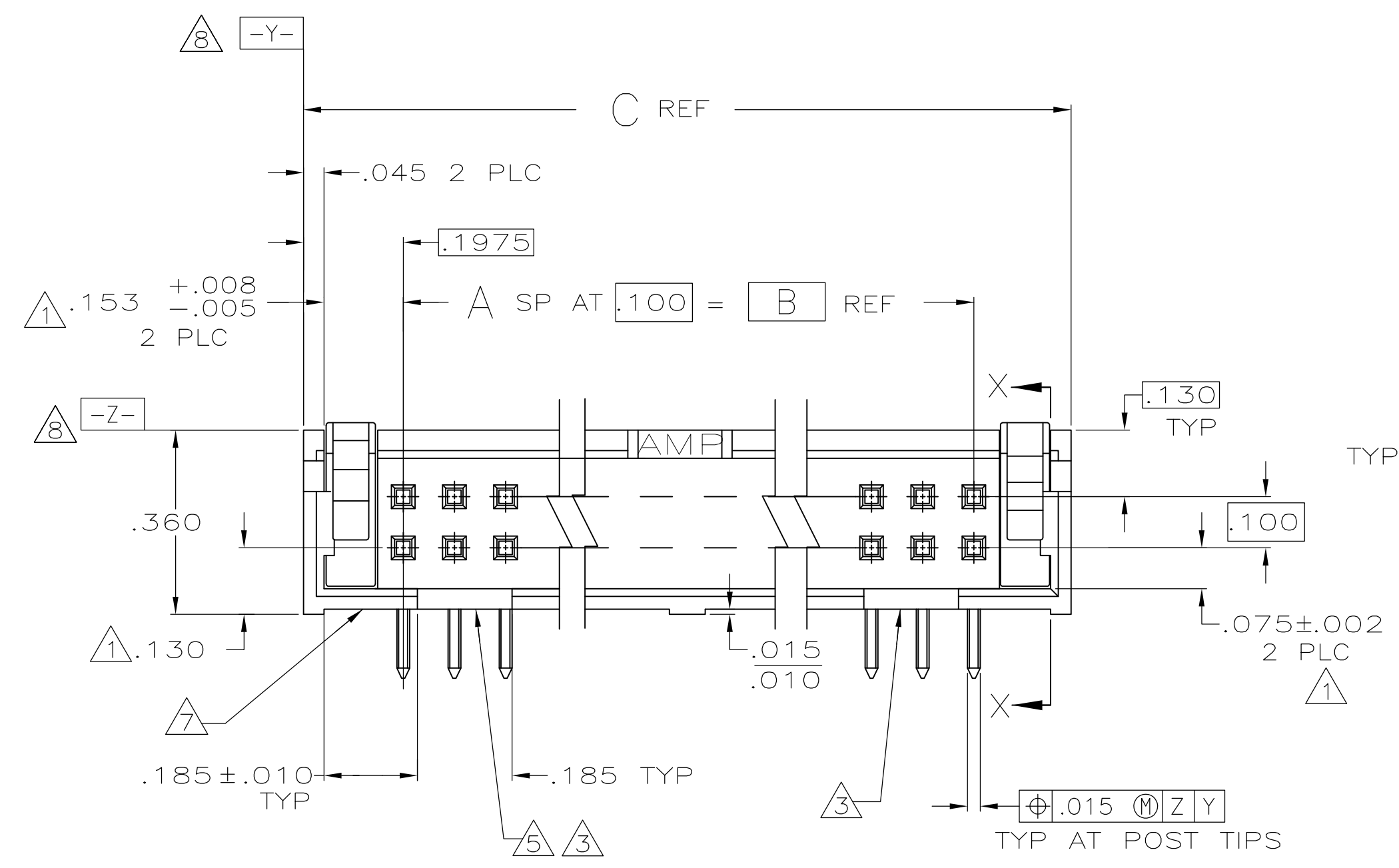
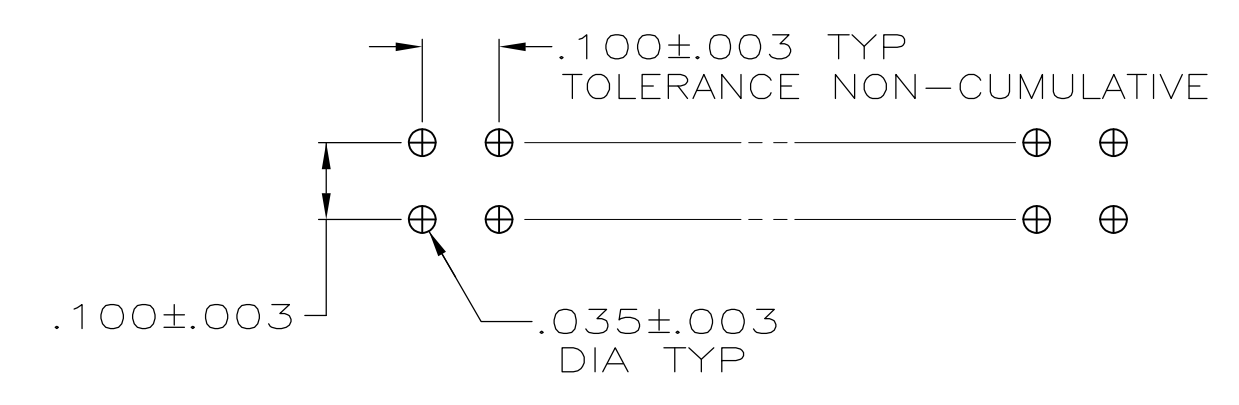

RECOMMENDED HOLE LAYOUT FOR MANUAL INSERTION

OBSOLETE	3.300	2.900	29	60	1-104130-0
OBSOLETE	2.800	2.400	24	50	104130-9
OBSOLETE	2.500	2.100	21	44	104130-8
OBSOLETE	2.300	1.900	19	40	104130-7
OBSOLETE	2.000	1.600	16	34	104130-6
	1.600	1.200	12	26	104130-5
	1.300	.900	9	20	104130-4
	1.100	.700	7	16	104130-3
	1.000	.600	6	14	104130-2
	.800	.400	4	10	104130-1
	C	B	A	NO OF POSN	ASSEMBLY PART NUMBER

THIS DRAWING IS A CONTROLLED DOCUMENT.

DIMENSIONS: INCHES	TOLERANCES UNLESS OTHERWISE SPECIFIED:	DIN H MOLL 2-26-87	CHK T CLARK 3-10-87	APVD R FLICKER 3-10-87	NAME
0 PLC ± -	1 PLC ± -	2 PLC ± -	3 PLC ± .005	4 PLC ± -	ANGLES ± -
MATERIAL: HOUSING: GLASS FILLED NYLON, FLAME RETARDANT, BLACK; POSTS: BRASS	FINISH	WEIGHT	SIZE: A1	CAGE CODE: 00779	DRAWING NO: 104130
CUSTOMER DRAWING		SCALE: 4:1	SHEET: 1 OF 1	REV: K1	RESTRICTED TO

STE TE Connectivity  
 PRODUCT SPEC: 108-40018  
 APPLICATION SPEC: AMP-LATCH