



TE Internal #: 140731-2

Ring Terminals & Spade Terminals, Ring Tongue, 22 – 16 AWG

Wire Size, .3 – 1.3 mm² Wire Size, 642.4 – 2583 CMA Wire Size, Stud Size 1/4

[View on TE.com >](#)

Terminals & Splices > Ring Terminals & Spade Terminals

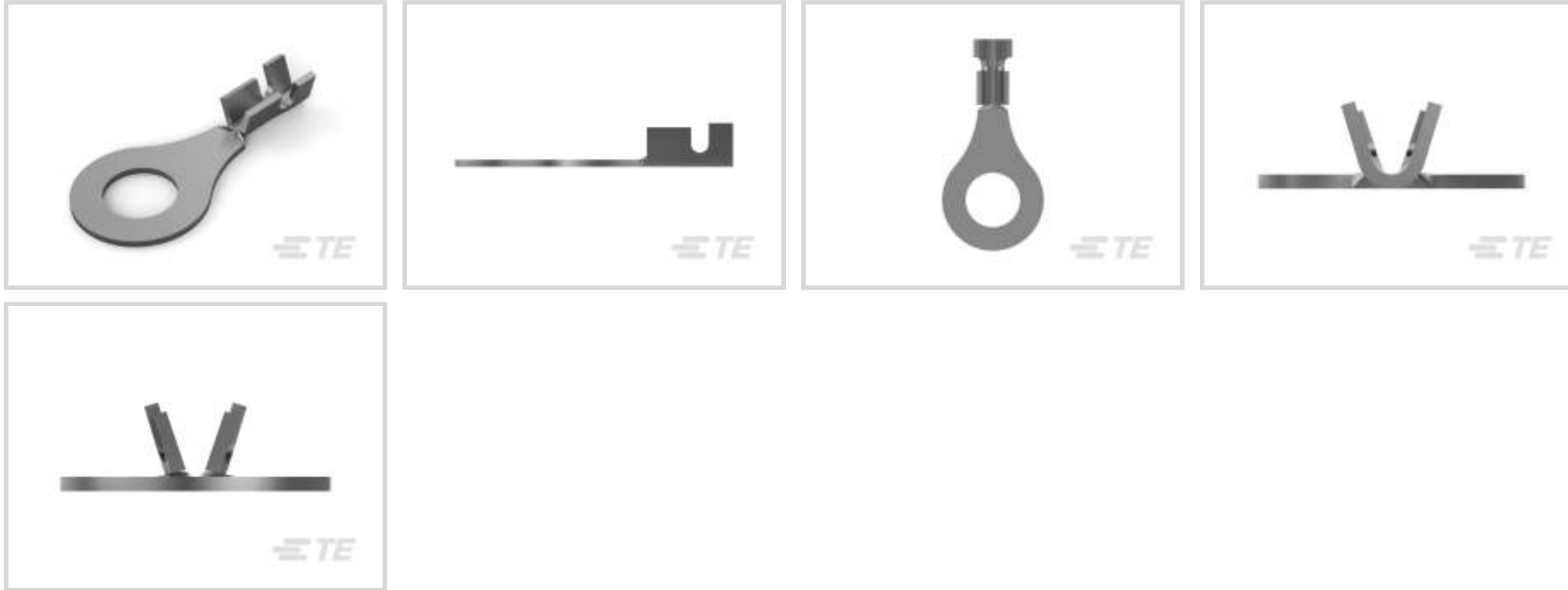

Ring & Spade Terminal Type: **Ring Tongue**

Wire Size: **642.4 – 2583 CMA**

Stud Size: **1/4**

Features

Product Type Features

Shape Description	Circular/Oval
Stud Size	1/4
Sealable	No
Compatible With Discrete Wire Type	Stranded
Wire Insulation Support Retention Type	Insulation Support

Configuration Features

Number of Holes	1
-----------------	---

Body Features

Product Weight	1.53 g
----------------	--------

Contact Features

Contact Base Material	Brass
Ring & Spade Terminal Type	Ring Tongue
Barrel Type	Open
Terminal Orientation	Straight
Terminal Plating Material	Tin
Contact Underplating Material	None

Mechanical Attachment

Wire Insulation Support	With
-------------------------	------

Dimensions

	.059 in
Wire Size	642.4 – 2583 CMA
Stud Diameter	6.3 mm[.24 in]
Tongue Thickness	.76 mm[.03 in]
Product Length	24.89 mm[.98 in]
Barrel Inside Diameter	.89 mm, 1.77 mm[.035 in][.07 in]
Compatible Insulation Diameter (Max)	.3 mm[.118 in]
Compatible Insulation Diameter Range	1.5 – 3 mm[.059 – .118 in]

Usage Conditions

Insulation Option	Uninsulated
Operating Temperature Range	-40 – 110 °C[-40 – 230 °F]

Operation/Application

Compatible With Wire Base Material	Copper
------------------------------------	--------

Industry Standards

Government Qualified Terminal	No
-------------------------------	----

Packaging Features

Packaging Quantity	5000
Packaging Method	Strip/Reel

Product Compliance

[For compliance documentation, visit the product page on TE.com>](#)

EU RoHS Directive 2011/65/EU	Compliant
EU ELV Directive 2000/53/EC	Compliant
China RoHS 2 Directive MIIT Order No 32, 2016	No Restricted Materials Above Threshold
EU REACH Regulation (EC) No. 1907/2006	Current ECHA Candidate List: JUNE 2023 (235) Candidate List Declared Against: JAN 2023 (233) Does not contain REACH SVHC
Halogen Content	Low Halogen - Br, Cl, F, I < 900 ppm per homogenous material. Also BFR/CFR/PVC

Free

Solder Process Capability

Not applicable for solder process capability

Product Compliance Disclaimer

This information is provided based on reasonable inquiry of our suppliers and represents our current actual knowledge based on the information they provided. This information is subject to change. The part numbers that TE has identified as EU RoHS compliant have a maximum concentration of 0.1% by weight in homogenous materials for lead, hexavalent chromium, mercury, PBB, PBDE, DBP, BBP, DEHP, DIBP, and 0.01% for cadmium, or qualify for an exemption to these limits as defined in the Annexes of Directive 2011/65/EU (RoHS2). Finished electrical and electronic equipment products will be CE marked as required by Directive 2011/65/EU. Components may not be CE marked. Additionally, the part numbers that TE has identified as EU ELV compliant have a maximum concentration of 0.1% by weight in homogenous materials for lead, hexavalent chromium, and mercury, and 0.01% for cadmium, or qualify for an exemption to these limits as defined in the Annexes of Directive 2000/53/EC (ELV). Regarding the REACH Regulation, the information TE provides on SVHC in articles for this part number is based on the latest European Chemicals Agency (ECHA) 'Guidance on requirements for substances in articles' posted at this URL: <https://echa.europa.eu/guidance-documents/guidance-on-reach>

Compatible Parts



TE Part # 160548-2
RING TONGUE 22-20 AWG .0120 X .290 PTPBR



TE Part # 2-2150318-2
OCEAN_2.0_Applicator-E-110F1400



TE Part # 2150318-2
OCEAN_2.0_Applicator-E-110F1400



TE Part # 7-2150318-2
OCEAN_2.0_Applicator-E-110F1400



KIT
REPRESENTATION ONLY

TE Part # 7-2150318-7
OCEAN_2.0_SPARE_PART_KIT-110F1400

Customers Also Bought



TE Part #160336-2
RING TONGUE IS 12-10 0.295 X .650 TPBR



TE Part #F08409-000
NC-229064-10-9



TE Part #2355002-1
MT Ferrule Kit,Plug,Without Pins,12-F,MM



TE Part #NB14872001
DWP-125-1/4-2-STK

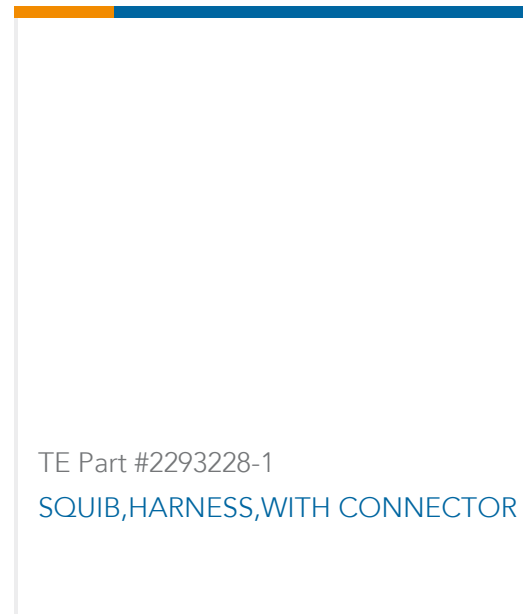
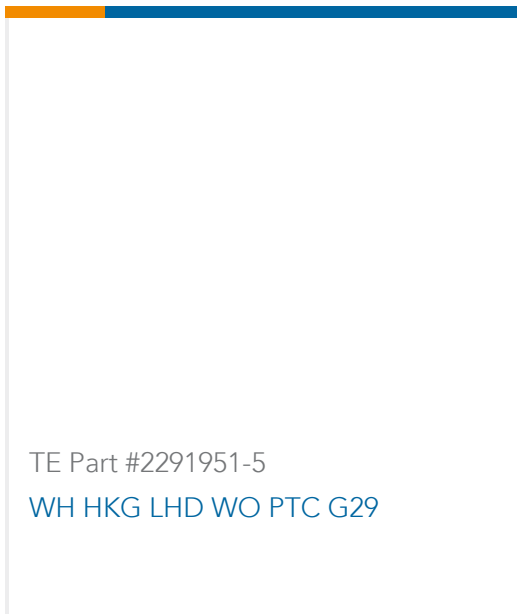
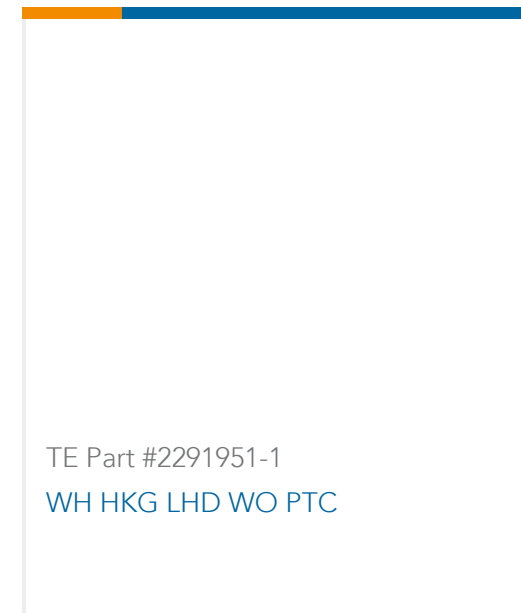
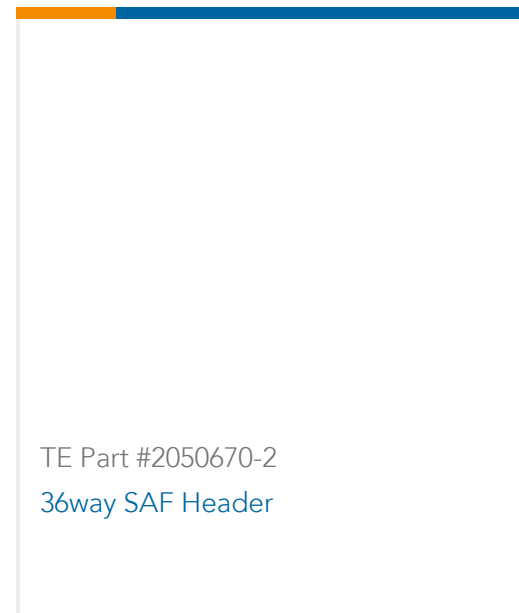
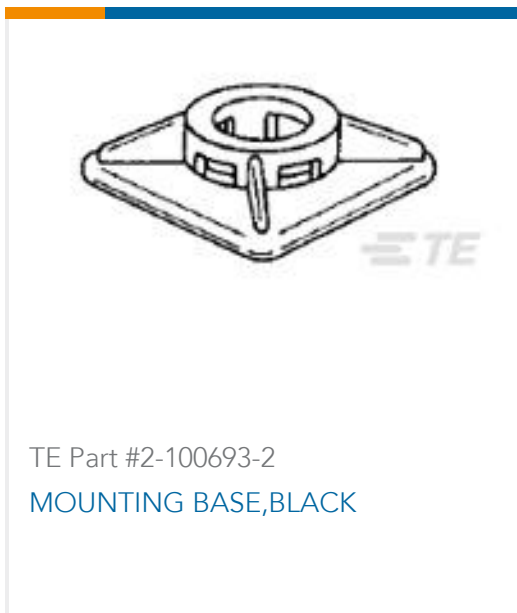

Documents

Product Drawings

RING TONGUE 1/4 22-16 AWG TPBR

French

CAD Files

3D PDF

3D

Customer View Model

[ENG_CVM_CVM_140731-2_K.2d_dxf.zip](#)

English

Customer View Model

[ENG_CVM_CVM_140731-2_K.3d_igs.zip](#)

English

Customer View Model

[ENG_CVM_CVM_140731-2_K.3d_stp.zip](#)

English

By downloading the CAD file I accept and agree to the [Terms and Conditions](#) of use.

Product Specifications

Application Specification

English

Product Environmental Compliance

Product Compliance Document

English

Product Compliance Document

English



[Agency Approvals](#)

[Agency Approval Document](#)

English