

LOC	DIST	REVISIONS					
		P.	LTN	DESCRIPTION	DATE	DWN	APVD
CM	00	E1		REVISED PER ECO-11-005027	16MAR2011	RK	HMR
		E2		REVISED PER ECR-21-101087	29APR2021	PJ	VS

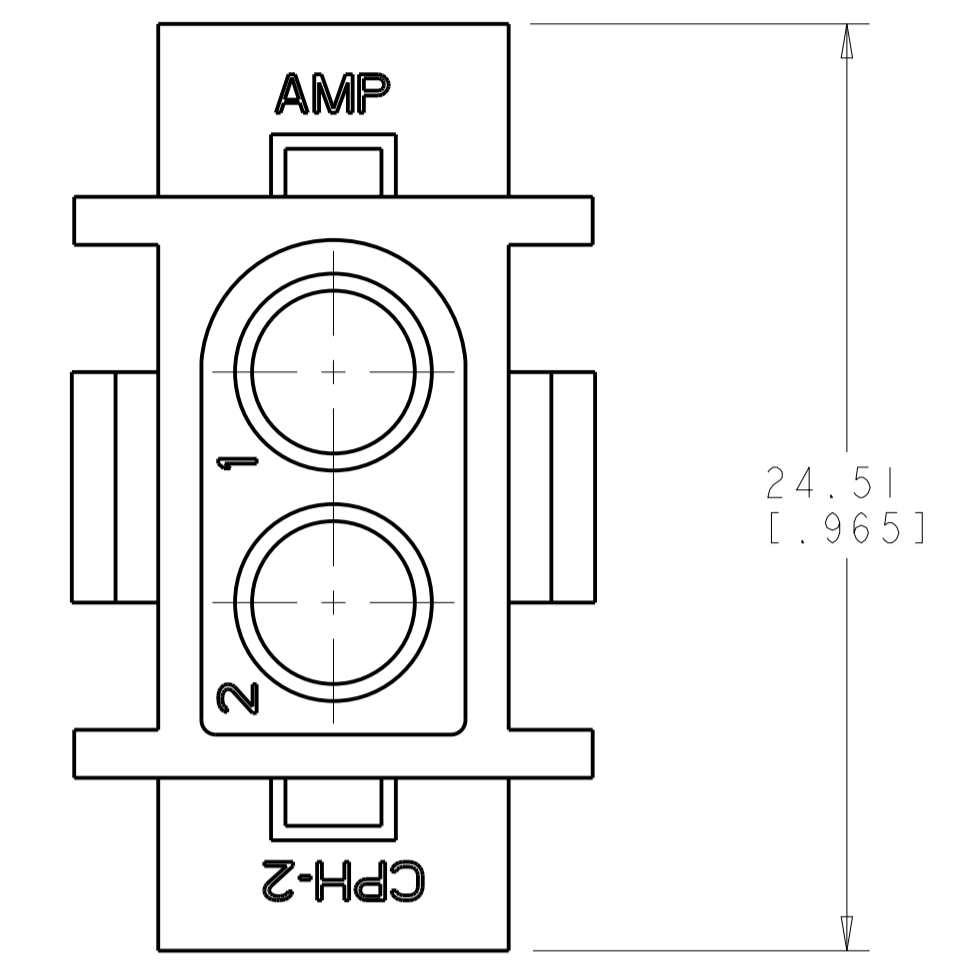

- NOTE DELETED.
 - ACCEPTS .140 SERIES PINS.
 - MATES WITH PLUG 350344.
- ⚠ 1.27 x 1.27 [.050 x .050] TABS IN CORNERS OF CUT-OUT ARE OPTIONAL TO REDUCE FLOAT IN PANEL.

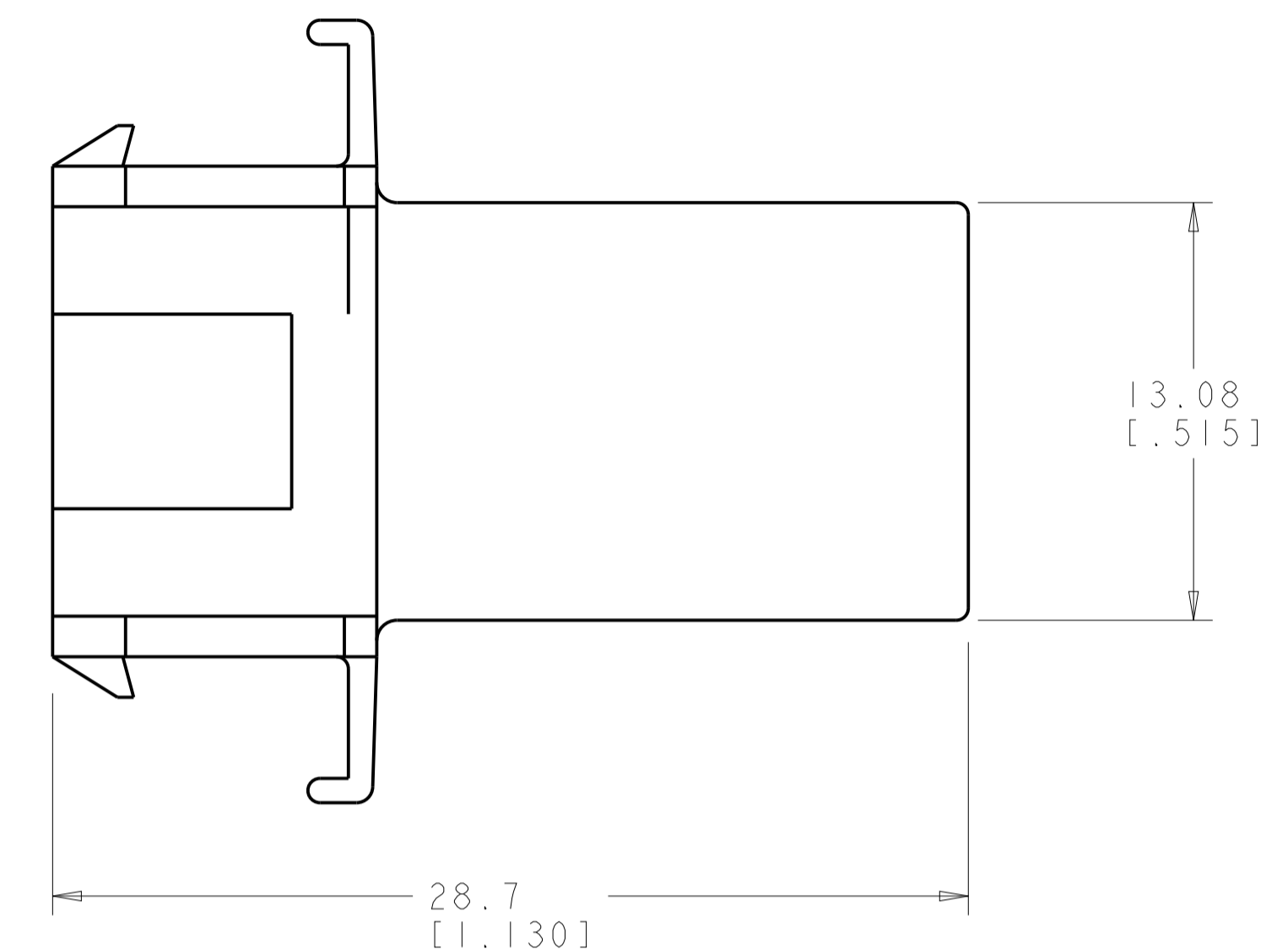
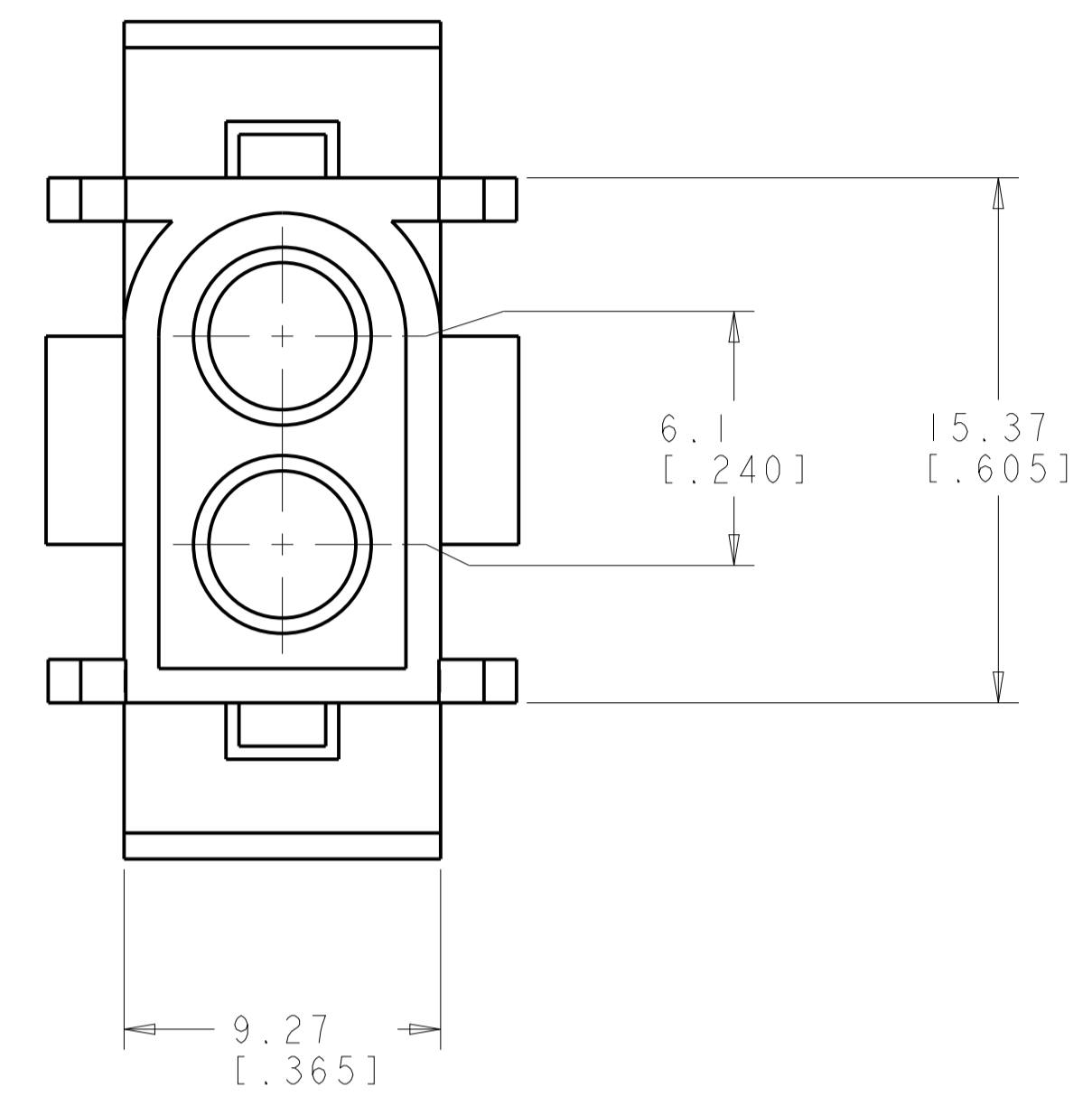
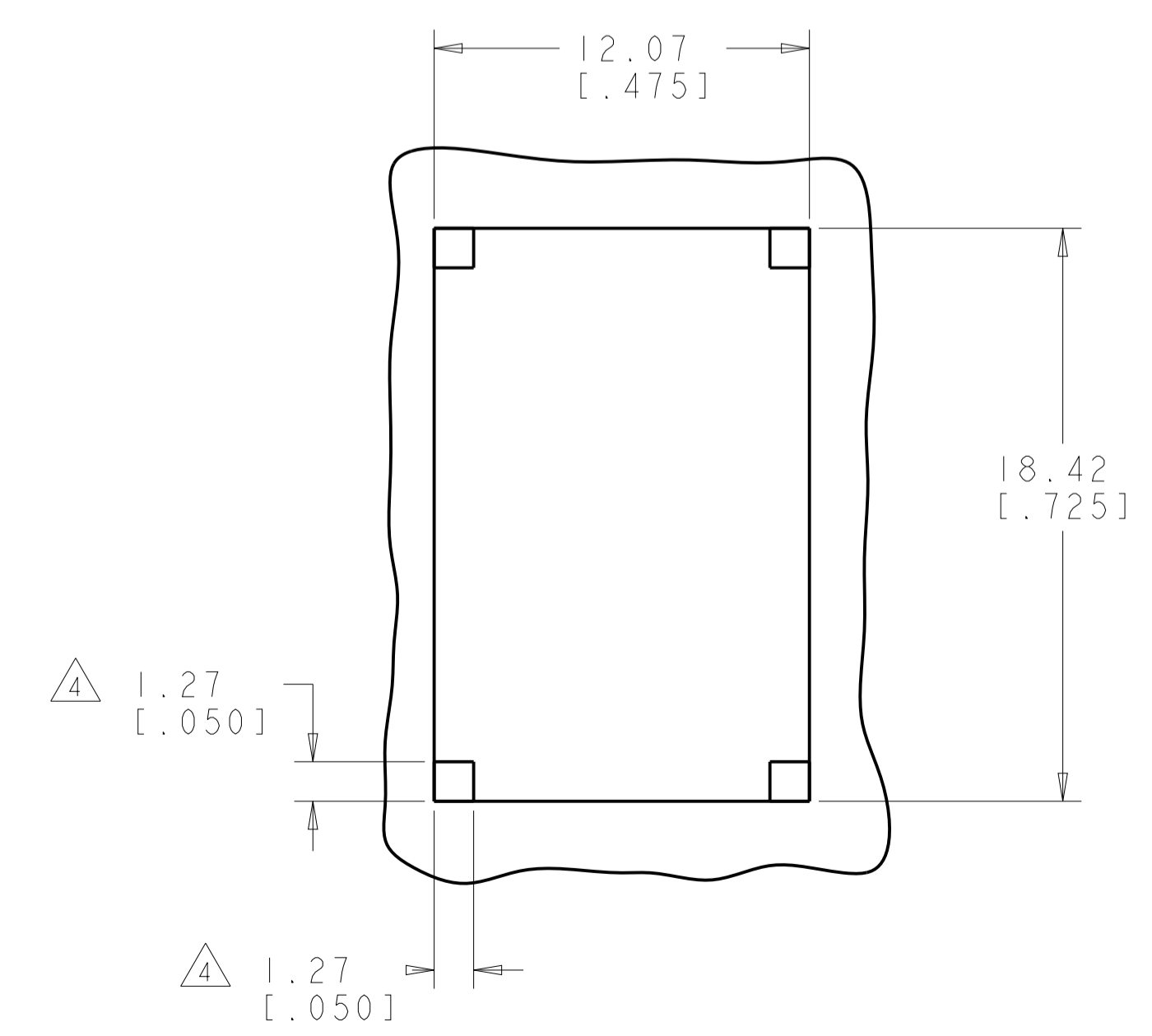
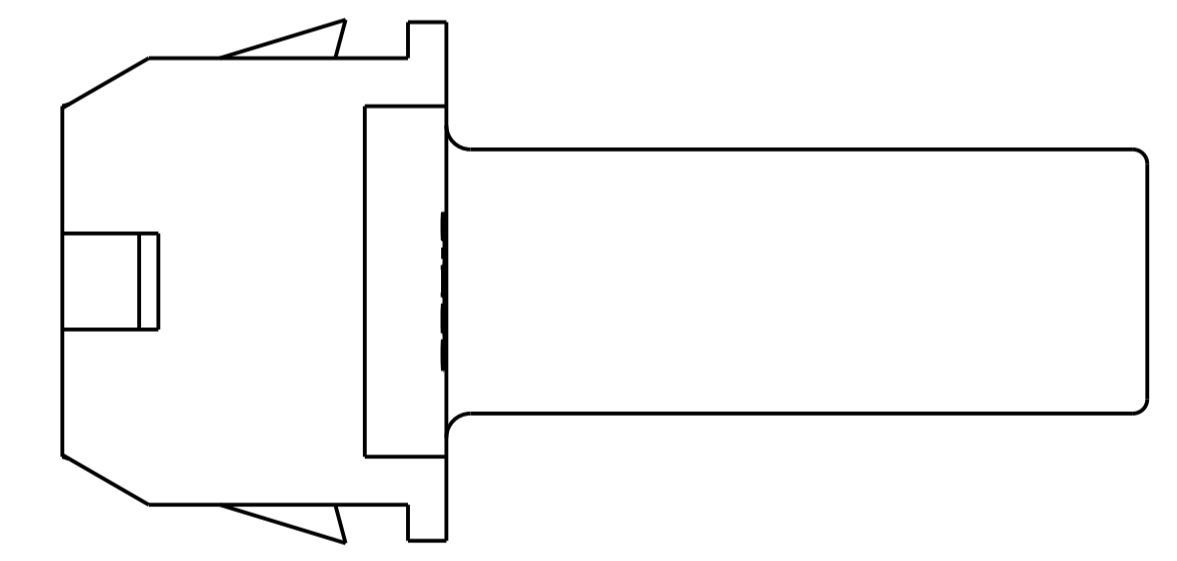

RECOMMENDED PANEL CUT-OUT,
PANEL THICKNESS 0.76-1.65 [.030-.065]

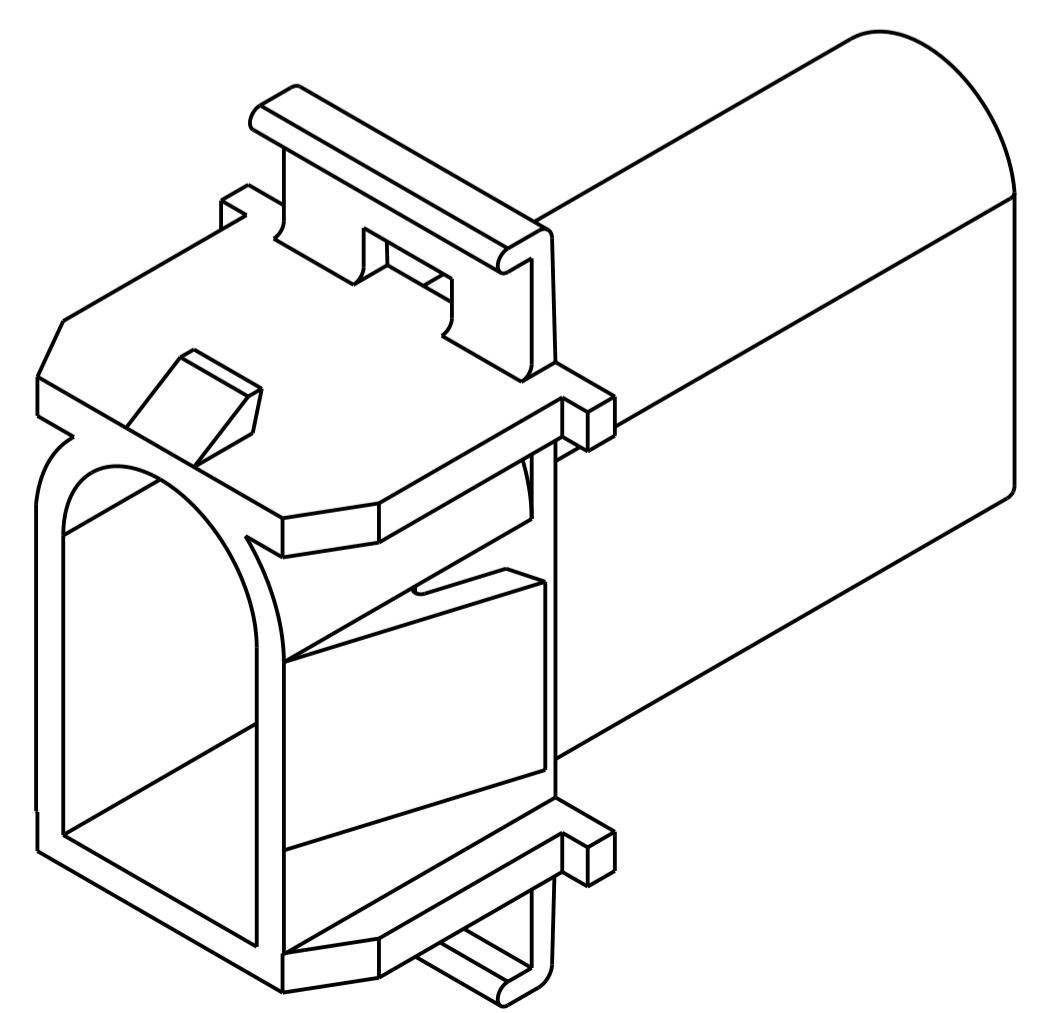

OBSOLETE	0.098 IN ³	GRAY	1-350345-0
	0.098 IN ³	NATURAL	1-350345-0
	VOLUME	COLOR	PART NUMBER

METRIC

THIS DRAWING IS A CONTROLLED DOCUMENT.		DWN R. WHITAKER 18APR2007	TE Connectivity	
DIMENSIONS: mm [INCHES]		CHK C. CASH 18APR2007	NAME CAP, 2 CIRCUIT, .140 MATE-N-LOK(TM)	
TOLERANCES UNLESS OTHERWISE SPECIFIED:		APVD C. CASH 18APR2007	PRODUCT SPEC	
0 PLC ±		APPLICATION SPEC		
1 PLC ±0.13 [.005]		SIZE A100779C=350345		
2 PLC ±		RESTRICTED TO		
3 PLC ±		CUSTOMER DRAWING		
4 PLC ±		SCALE 5:1 SHEET 1 OF 1 REV E2		
ANGLES 40°/30°				
MATERIAL NYLON				
FINISH				