

PART NUMBER DATA									
CIRCUITS	A IN	mm	B IN	mm	C IN	mm	D IN	mm	
2	1.58	40.2	.375	9.52	1.125	28.58	.83	21.1	
3	1.96	49.7	.750	19.05	1.500	38.10	1.21	30.7	
4	2.33	59.2	1.125	28.58	1.875	47.63	1.58	40.2	
5	2.71	68.7	1.500	38.10	2.250	57.15	1.96	49.7	
6	3.08	78.3	1.875	47.63	2.625	66.68	2.33	59.2	
7	3.46	87.8	2.250	57.15	3.000	76.20	2.71	68.8	
8	3.83	97.3	2.625	66.68	3.375	85.73	3.08	78.3	
9	4.21	106.8	3.000	76.20	3.750	95.25	3.46	87.8	
10	4.58	116.4	3.375	85.73	4.125	104.78	3.83	97.3	
11	4.96	125.9	3.750	95.25	4.500	114.30	4.21	106.9	
12	5.33	135.4	4.125	104.78	4.875	123.83	4.58	116.4	
13	5.71	144.9	4.500	114.30	5.250	133.35	4.96	125.9	
14	6.08	154.5	4.875	123.83	5.625	142.88	5.33	135.4	
15	6.46	164.0	5.250	133.35	6.000	152.40	5.71	145.0	
16	6.83	173.5	5.625	142.88	6.375	161.93	6.08	154.5	
17	7.21	183.0	6.000	152.40	6.750	171.45	6.46	164.0	
18	7.58	192.6	6.375	161.93	7.125	180.98	6.83	173.5	
19	7.96	202.1	6.750	171.45	7.500	190.50	7.21	183.1	
20	8.33	211.6	7.125	180.98	7.875	200.03	7.58	192.6	
21	8.71	221.1	7.500	190.50	8.250	209.55	7.96	202.1	
22	9.08	230.7	7.875	200.03	8.625	219.08	8.33	211.6	
23	9.46	240.2	8.250	209.55	9.000	228.60	8.71	221.2	
24	9.83	249.7	8.625	219.08	9.375	238.13	9.08	230.7	
25	10.21	259.2	9.000	228.60	9.750	247.65	9.46	240.2	
26	10.58	268.8	9.375	238.13	10.125	257.18	9.83	249.7	

PART NUMBER LEGEND

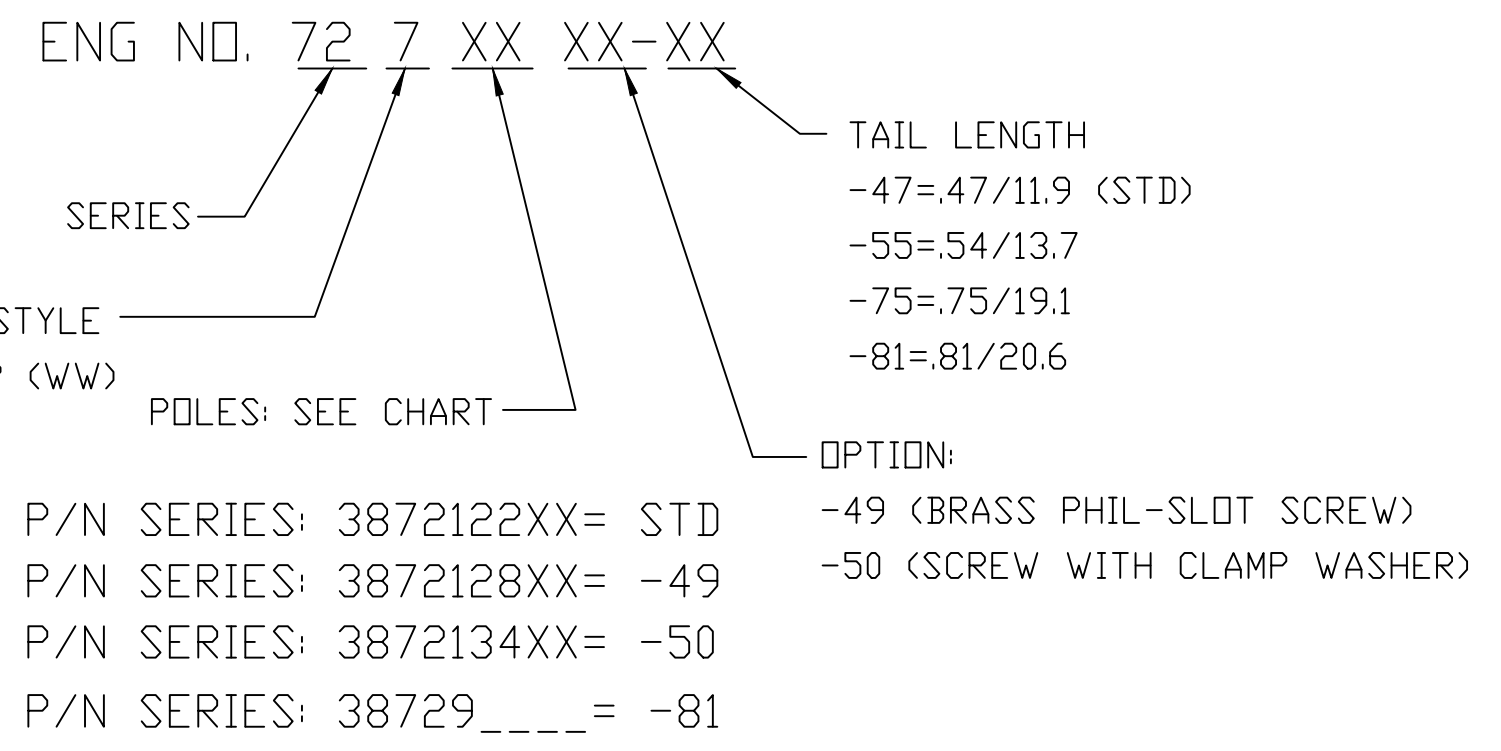

- NOTES:
1. MATERIAL: SEE TABLE
 2. ASSEMBLY MUST MEET BEAU WORKMANSHIP STANDARD ES-19900-059
 3. PRODUCT SPECIFICATION: PS-38710-001
 4. SEE SAP BOM FOR COMPONENT PART NUMBERS
 5. "XX" REFERS TO THE QUANTITY OF CIRCUITS

REF. THIS DRAWING SUPERSEDES E-78721-003 REV-B

6	XX	#6-32 PH/SLOTTED SCREW (OPTION -50)	380010099	2504-9201-C220
5	XX	#6-32 PH/SLOTTED SCREW (OPTION -49)	380010058	1804-9101-A120
4	XX	#6-32 PH/SLOTTED SCREW (STD)	380010092	2504-9101-C220
3	2	MOUNTING PLATE	380021308	7204-7201-A120
2	XX	TERMINAL	380021279	7204-3411-A260
1	1	BARRIER TERMINAL STRIP	38728_____	7200-XX02-V000
ITEM	QTY	DESCRIPTION	MATERIAL NO.	ENGINEERING NO.

RELEASED EC NO: IPG2015-0118
 DRWN: RSTONE 2014/07/18
 CHKD: BARDEN 2014/07/23
 APPR: JFMURPHY 2014/08/02

QUALITY SYMBOL
 ▽=0
 ▽=0

DESCRIPTION
 A REV

GENERAL TOLERANCES (UNLESS SPECIFIED)

	mm	INCH
4 PLACES	±---	±---
3 PLACES	±---	±.005
2 PLACES	±0.13	±.01
1 PLACE	±0.3	±---

ANGULAR ±---°

DRAFT WHERE APPLICABLE MUST REMAIN WITHIN DIMENSIONS

DIMENSION STYLE IN/MM

SCALE ---

DESIGN UNITS INCH

THIRD ANGLE PROJECTION

DRAWN BY RSTONE DATE 2014/07/18

CHECKED BY DATE

APPROVED BY JFMURPHY DATE 2014/08/02

MATERIAL NO. SEE PART LEGEND

DOCUMENT NO. E-38721-010

SHEET NO. 1 OF 1

THIS DRAWING CONTAINS INFORMATION THAT IS PROPRIETARY TO MOLEX INCORPORATED AND SHOULD NOT BE USED WITHOUT WRITTEN PERMISSION

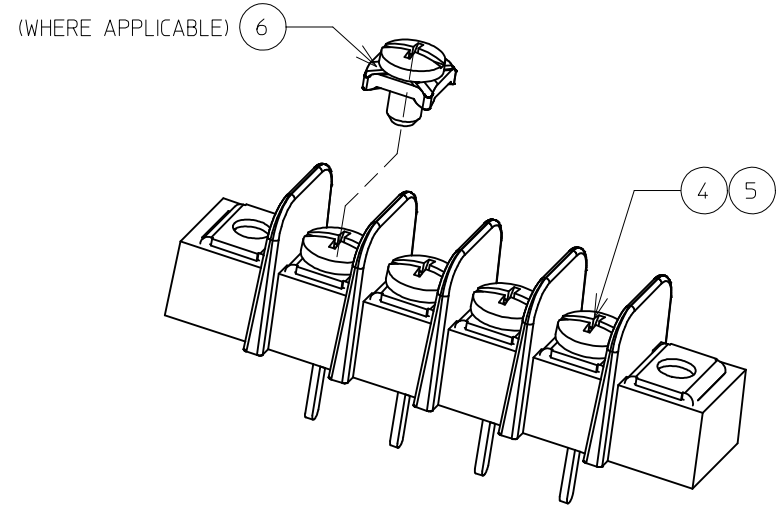
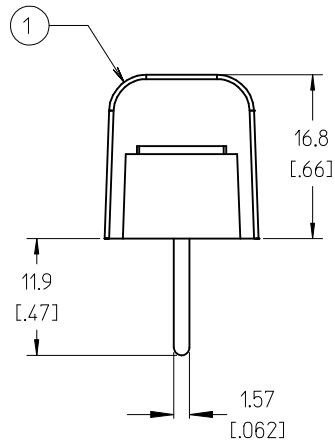
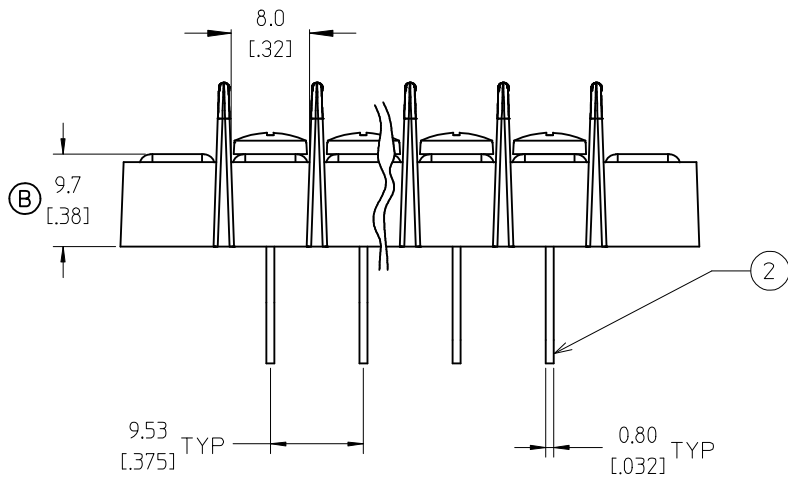
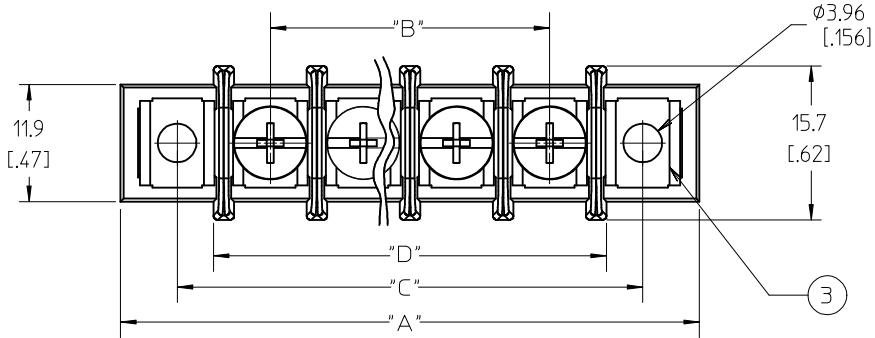

NOTES:

1. MATERIAL: SEE TABLE
2. FINISHES: SEE TABLE
3. PRODUCT SPECIFICATION: NOT REQUIRED
4. PACKAGING: NOT REQUIRED
5. MATES WITH: NONE
6. "XX" REFERS TO THE QUANTITY OF CIRCUITS.
7. ALL COMPONENTS ARE ROHS COMPLIANT.

ITEM	QTY	DESCRIPTION	MATERIAL	FINISH
6	XX	#6-32 PH/SLOTTED SCREW (OPTION -50)	STEEL	ZN, CLEAR CHROMATE
5	XX	#6-32 PH/SLOTTED SCREW (OPTION -49)	BRASS	NICKEL PLATE
4	XX	#6-32 PH/SLOTTED SCREW (STD)	STEEL	ZN, CLEAR CHROMATE
3	2	MOUNTING PLATE	BRASS	NICKEL PLATE
2	XX	TERMINAL	BRASS	TIN PLATE
1	1	BARRIER TERMINAL STRIP	PBT	BLACK

UPDATE TERM. HEIGHT DIM.	EC NO: WNA2009-0445
DRWN: JENC INAS	2009/07/01
CHKD: CYORK	2009/07/02
APPR: JMACNE IL	2009/07/02

QUALITY SYMBOLS	$\nabla=0$
	$\nabla=0$

GENERAL TOLERANCES (UNLESS SPECIFIED)	mm	INCH
4 PLACES	\pm ---	\pm ---
3 PLACES	\pm ---	\pm .005
2 PLACES	\pm 0.13	\pm .01
1 PLACE	\pm 0.3	\pm ---
ANGULAR \pm 2 °		
DRAFT WHERE APPLICABLE MUST REMAIN WITHIN DIMENSIONS		

DIMENSION STYLE	MM/IN
DRAWN BY	DATE
C. YORK	2006/03/24
CHECKED BY	DATE
RDEROSS	2006/03/24
APPROVED BY	DATE
RDEROSS	2006/03/24
MATERIAL NO.	
SEE CHART	

SCALE	2:1	DESIGN UNITS	INCH	THIRD ANGLE PROJECTION
TITLE				
SR BTS, WW, ASSY				
9.53 MM [0.375] CENTERS				
MATERIAL NO. SD-38721-003				
DOCUMENT NO. SD-38721-003				
SHEET NO. 1 OF 2				
THIS DRAWING CONTAINS INFORMATION THAT IS PROPRIETARY TO MOLEX INCORPORATED AND SHOULD NOT BE USED WITHOUT WRITTEN PERMISSION				

NUMBER OF CIRCUITS "XX"	DIM. "A"		DIM. "B"		DIM. "C"		DIM. "D"	
02	40.1	[1.58]	9.53	[.375]	28.6	[1.13]	21.1	[.83]
03	49.7	[1.96]	19.05	[.750]	38.1	[1.50]	30.6	[1.21]
04	59.2	[2.33]	28.58	[1.125]	47.6	[1.88]	40.1	[1.58]
05	68.7	[2.71]	38.10	[1.500]	57.2	[2.25]	49.7	[1.96]
06	78.2	[3.08]	47.63	[1.875]	66.7	[2.63]	59.2	[2.33]
07	87.8	[3.46]	57.15	[2.250]	76.2	[3.00]	68.7	[2.71]
08	97.3	[3.83]	66.68	[2.625]	85.7	[3.38]	78.2	[3.08]
09	106.8	[4.21]	76.20	[3.000]	95.3	[3.75]	87.8	[3.46]
10	116.3	[4.58]	85.73	[3.375]	104.8	[4.13]	97.3	[3.83]
11	125.9	[4.96]	95.25	[3.750]	114.3	[4.50]	106.8	[4.21]
12	135.4	[5.33]	104.78	[4.125]	123.8	[4.88]	116.3	[4.58]
13	144.9	[5.71]	114.30	[4.500]	133.4	[5.25]	125.9	[4.96]
14	154.4	[6.08]	123.83	[4.875]	142.9	[5.63]	135.4	[5.33]
15	164.0	[6.46]	133.35	[5.250]	152.4	[6.00]	144.9	[5.71]
16	173.5	[6.83]	142.88	[5.625]	161.9	[6.38]	154.4	[6.08]
17	183.0	[7.21]	152.40	[6.000]	171.5	[6.75]	164.0	[6.46]
18	192.5	[7.58]	161.93	[6.375]	181.0	[7.13]	173.5	[7.21]
19	202.1	[7.96]	171.45	[6.750]	190.5	[7.50]	192.5	[7.58]
20	211.6	[8.33]	180.98	[7.125]	200.0	[7.88]	202.1	[7.96]
21	221.1	[8.71]	190.50	[7.500]	209.6	[8.25]	211.6	[8.33]
22	230.6	[9.08]	200.03	[7.875]	219.1	[8.63]	221.1	[8.71]
23	240.2	[9.46]	209.55	[8.250]	228.6	[9.00]	230.6	[9.08]
24	249.7	[9.83]	219.08	[8.625]	238.1	[9.38]	230.6	[9.08]
25	259.2	[10.21]	228.60	[9.000]	247.7	[9.75]	240.2	[9.46]
26	268.7	[10.58]	238.13	[9.375]	257.2	[10.13]	249.7	[9.83]

MATERIAL NO. (OPTION -50)	MATERIAL NO. (OPTION -49)	MATERIAL NO. (STANDARD)	NUMBER OF CIRCUITS "XX"
38721-3402	38721-2802	38721-2202	02
38721-3403	38721-2803	38721-2203	03
38721-3404	38721-2804	38721-2204	04
38721-3405	38721-2805	38721-2205	05
38721-3406	38721-2806	38721-2206	06
38721-3407	38721-2807	38721-2207	07
38721-3408	38721-2808	38721-2208	08
38721-3409	38721-2809	38721-2209	09
38721-3410	38721-2810	38721-2210	10
38721-3411	38721-2811	38721-2211	11
38721-3412	38721-2812	38721-2212	12
38721-3413	38721-2813	38721-2213	13
38721-3414	38721-2814	38721-2214	14
38721-3415	38721-2815	38721-2215	15
38721-3416	38721-2816	38721-2216	16
38721-3417	38721-2817	38721-2217	17
38721-3418	38721-2818	38721-2218	18
38721-3419	38721-2819	38721-2219	19
38721-3420	38721-2820	38721-2220	20
38721-3421	38721-2821	38721-2221	21
38721-3422	38721-2822	38721-2222	22
38721-3423	38721-2823	38721-2223	23
38721-3424	38721-2824	38721-2224	24
38721-3425	38721-2825	38721-2225	25
38721-3426	38721-2826	38721-2226	26

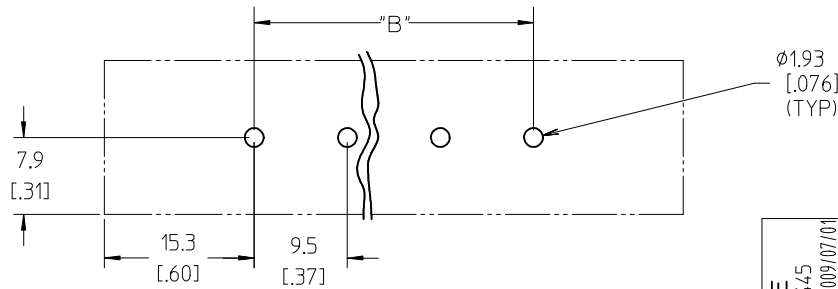

SEE SHEET ONE EC NO: WNA2009-0445 DRWN: JENC INAS 2009/07/01 CHKD: CYORK 2009/07/02 APPR: JMACNE IL 2009/07/02	QUALITY SYMBOLS ▽=0 ▽=0	GENERAL TOLERANCES (UNLESS SPECIFIED) <table border="1"> <tr><th colspan="2">mm</th><th colspan="2">INCH</th></tr> <tr><td>4 PLACES</td><td>± ---</td><td>± ---</td><td></td></tr> <tr><td>3 PLACES</td><td>± ---</td><td>± .005</td><td></td></tr> <tr><td>2 PLACES</td><td>± 0.13</td><td>± .01</td><td></td></tr> <tr><td>1 PLACE</td><td>± 0.3</td><td>± ---</td><td></td></tr> </table>	mm		INCH		4 PLACES	± ---	± ---		3 PLACES	± ---	± .005		2 PLACES	± 0.13	± .01		1 PLACE	± 0.3	± ---		DIMENSION STYLE MM/IN	SCALE 2:1	DESIGN UNITS INCH	THIRD ANGLE PROJECTION
	mm		INCH																							
	4 PLACES	± ---	± ---																							
	3 PLACES	± ---	± .005																							
2 PLACES	± 0.13	± .01																								
1 PLACE	± 0.3	± ---																								
DRAWN BY C. YORK	DATE 2006/03/24	TITLE SR BTS, WW, ASSY 9.53 MM [.375] CENTERS																								
CHECKED BY RDEROSS	DATE 2006/03/24	MOLEX INCORPORATED																								
APPROVED BY RDEROSS	DATE 2006/03/24	MATERIAL NO. SEE CHART	DOCUMENT NO. SD-38721-003	SHEET NO. 2 OF 2																						

DRAFT WHERE APPLICABLE MUST REMAIN WITHIN DIMENSIONS

THIS DRAWING CONTAINS INFORMATION THAT IS PROPRIETARY TO MOLEX INCORPORATED AND SHOULD NOT BE USED WITHOUT WRITTEN PERMISSION

ISO VIEW
4 CIRCUIT SHOWN

PART NUMBER DATA

CIRCUITS	A IN		B IN		C IN		D IN	
	mm	mm	mm	mm	mm	mm	mm	mm
2	1.58	40.2	.375	9.52	1.125	28.58	.83	21.1
3	1.96	49.7	.750	19.05	1.500	38.10	1.21	30.7
4	2.33	59.2	1.125	28.58	1.875	47.63	1.58	40.2
5	2.71	68.7	1.500	38.10	2.250	57.15	1.96	49.7
6	3.08	78.3	1.875	47.63	2.625	66.68	2.33	59.2
7	3.46	87.8	2.250	57.15	3.000	76.20	2.71	68.8
8	3.83	97.3	2.625	66.68	3.375	85.73	3.08	78.3
9	4.21	106.8	3.000	76.20	3.750	95.25	3.46	87.8
10	4.58	116.4	3.375	85.73	4.125	104.78	3.83	97.3
11	4.96	125.9	3.750	95.25	4.500	114.30	4.21	106.9
12	5.33	135.4	4.125	104.78	4.875	123.83	4.58	116.4
13	5.71	144.9	4.500	114.30	5.250	133.35	4.96	125.9
14	6.08	154.5	4.875	123.83	5.625	142.88	5.33	135.4
15	6.46	164.0	5.250	133.35	6.000	152.40	5.71	145.0
16	6.83	173.5	5.625	142.88	6.375	161.93	6.08	154.5
17	7.21	183.0	6.000	152.40	6.750	171.45	6.46	164.0
18	7.58	192.6	6.375	161.93	7.125	180.98	6.83	173.5
19	7.96	202.1	6.750	171.45	7.500	190.50	7.21	183.1
20	8.33	211.6	7.125	180.98	7.875	200.03	7.58	192.6
21	8.71	221.1	7.500	190.50	8.250	209.55	7.96	202.1
22	9.08	230.7	7.875	200.03	8.625	219.08	8.33	211.6
23	9.46	240.2	8.250	209.55	9.000	228.60	8.71	221.2
24	9.83	249.7	8.625	219.08	9.375	238.13	9.08	230.7
25	10.21	259.2	9.000	228.60	9.750	247.65	9.46	240.2
26	10.58	268.8	9.375	238.13	10.125	257.18	9.83	249.7

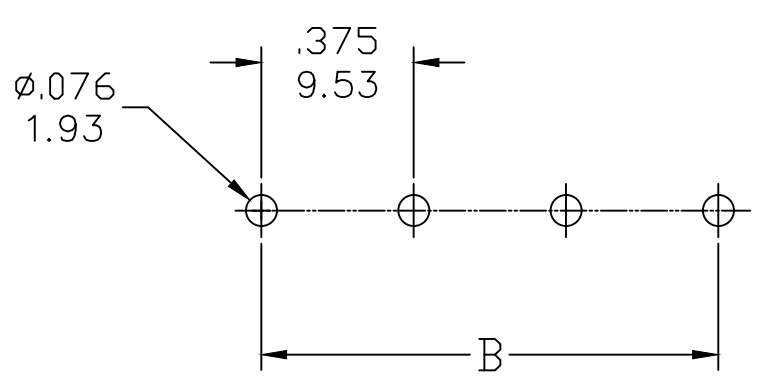
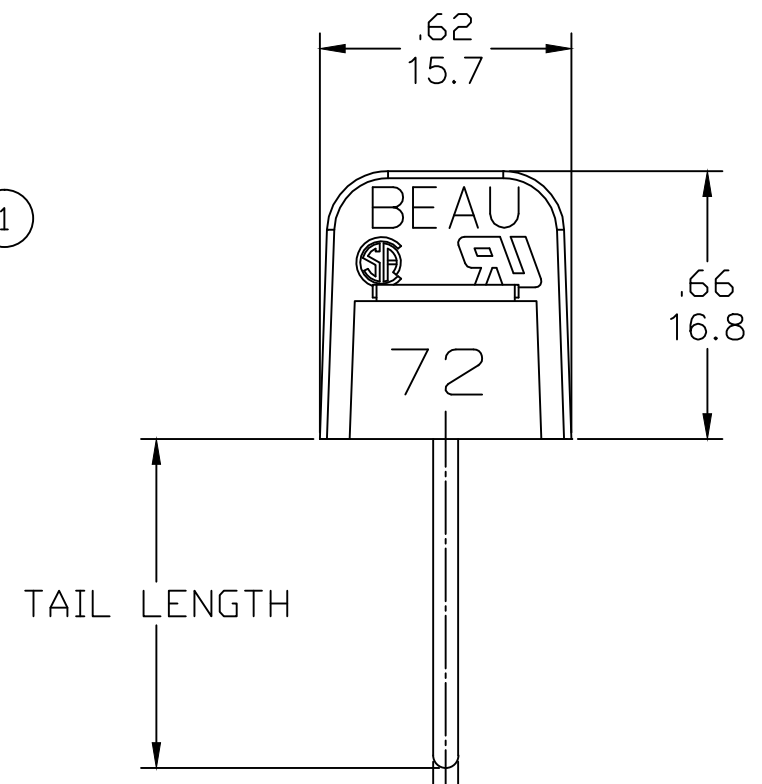
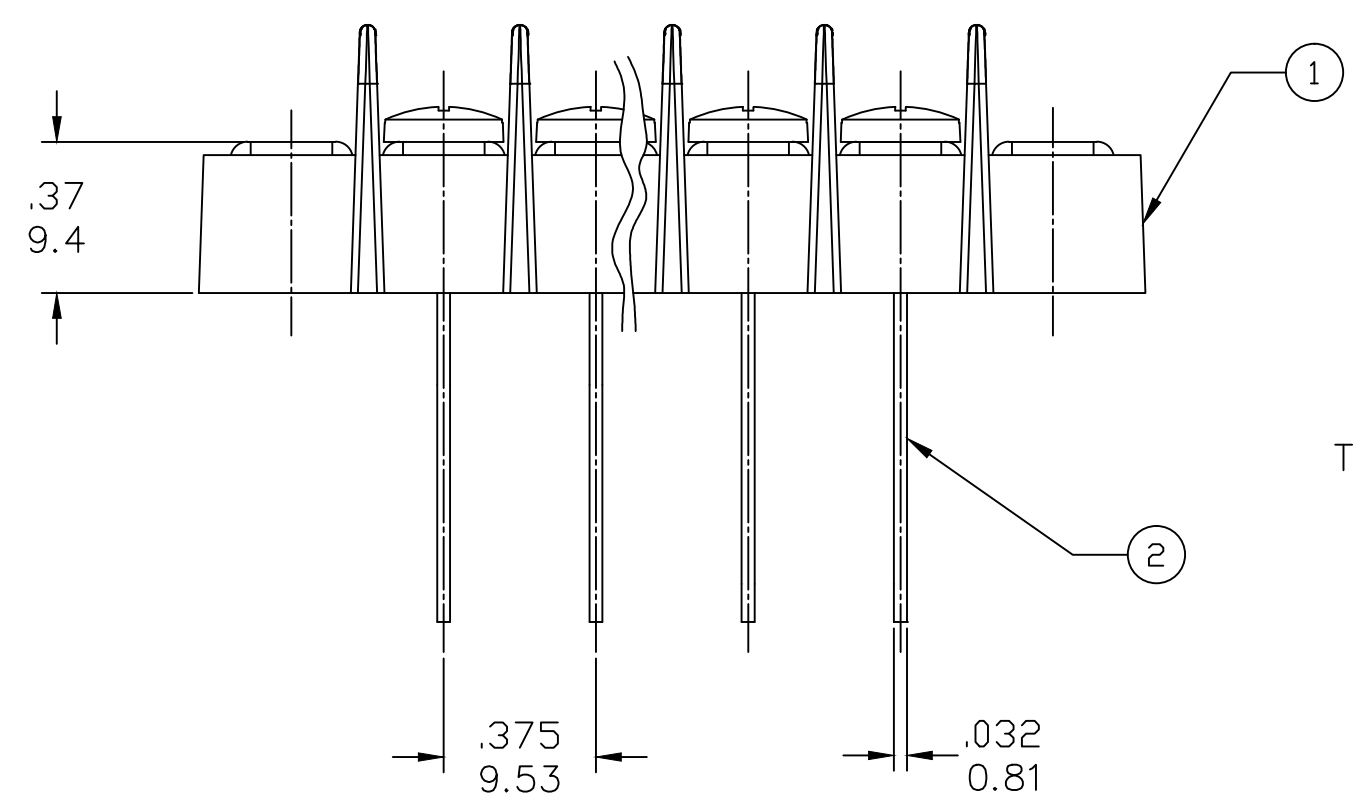
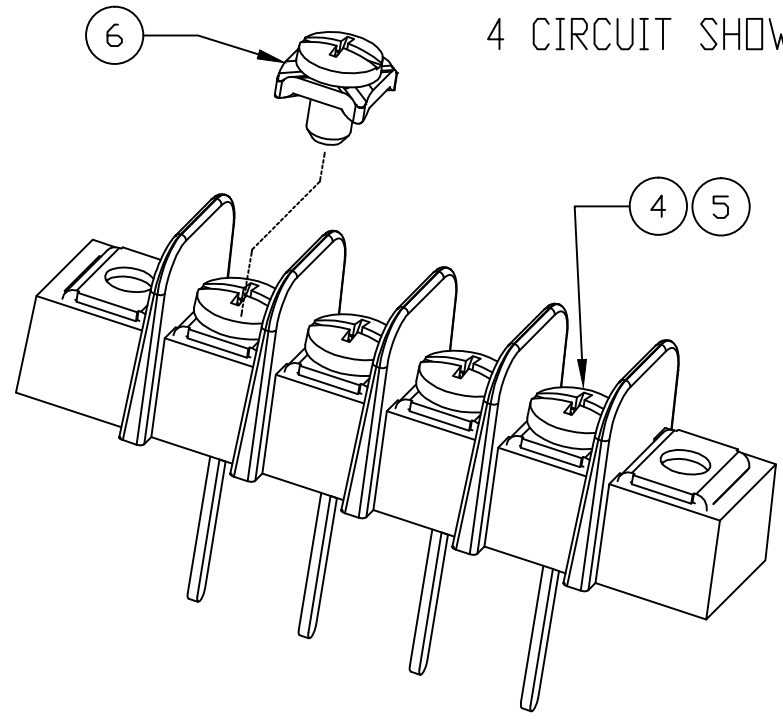
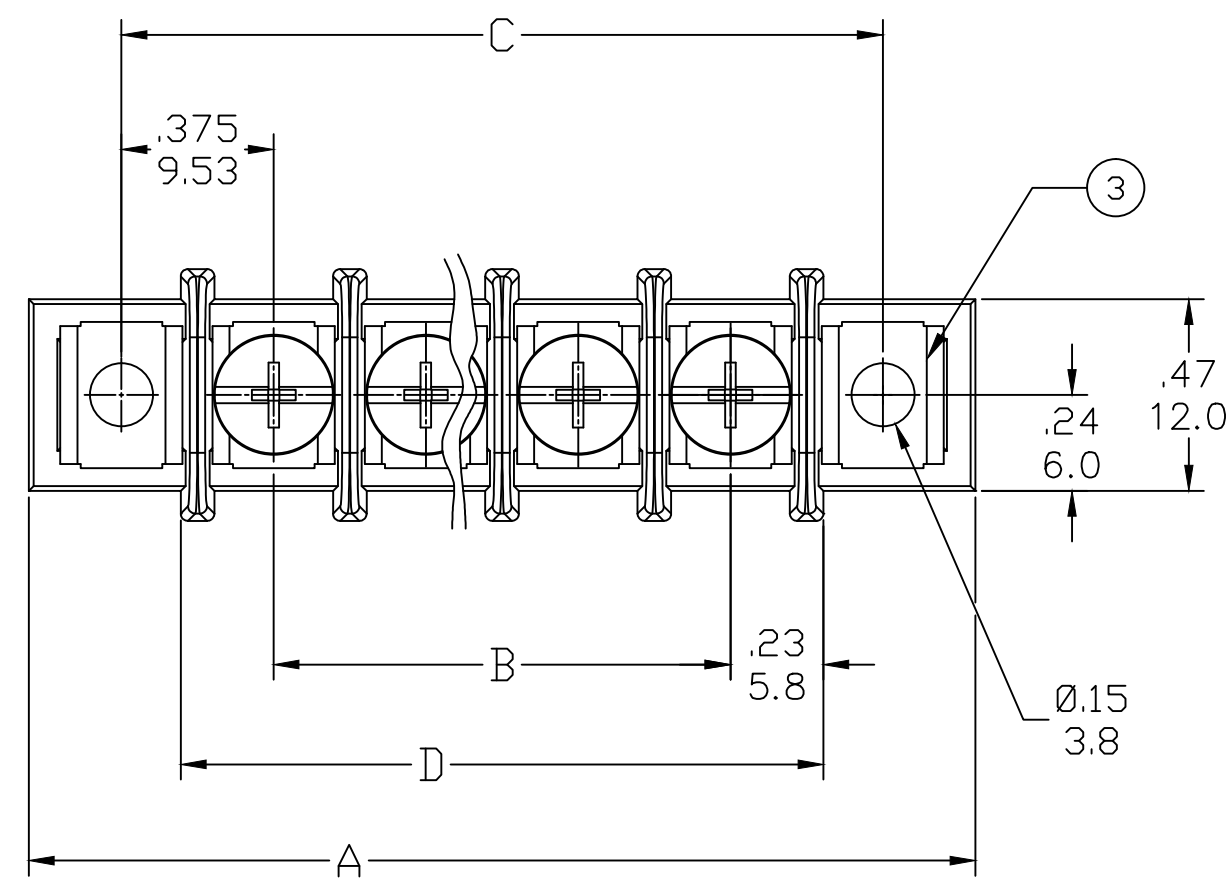

PART NUMBER LEGEND

ENG NO. 72 7 XX XX-XX

SERIES: 72, 7, XX, XX-XX
 TAIL LENGTH:
 -47=.47/11.9 (STD)
 -55=.54/13.7
 -75=.75/19.1
 -81=.81/20.6
 OPTION:
 -49 (BRASS PHIL-SLOT SCREW)
 -50 (SCREW WITH CLAMP WASHER)
 SAP P/N SERIES: 3872122XX= STD
 SAP P/N SERIES: 3872128XX= -49
 SAP P/N SERIES: 3872134XX= -50
 SAP P/N SERIES: 38729___= -81

- NOTES:
- MATERIAL: SEE TABLE
 - FINISHES: SEE TABLE
 - PRODUCT SPECIFICATION: PS-38710-001
 - "XX" REFERS TO THE QUANTITY OF CIRCUITS
 - DIMS SHOWN ARE FOR REFERENCE ONLY

REF. THIS DRAWING SUPERSEDES SD-78721-003 REV-B

ITEM	QTY	DESCRIPTION	MATERIAL	FINISH
6	XX	#6-32 PH/SLOTTED SCREW (OPTION -50)	STEEL	ZN, CLEAR CHROMATE
5	XX	#6-32 PH/SLOTTED SCREW (OPTION -49)	BRASS	NICKEL PLATE
4	XX	#6-32 PH/SLOTTED SCREW (STD)	STEEL	ZN, CLEAR CHROMATE
3	2	MOUNTING PLATE	BRASS	NICKEL PLATE
2	XX	TERMINAL	BRASS	TIN PLATE
1	1	BARRIER TERMINAL STRIP	PBT	BLACK

RELEASED	EC NO: ICG2015-0118	DRWN: RSTONE 2014/07/17	CHKD: BARDEN 2014/07/23	APPR: JFMURPHY 2014/08/02	DESCRIPTION
QUALITY SYMBOL	0	0			

GENERAL TOLERANCES (UNLESS SPECIFIED)	DIMENSION STYLE IN/MM		SCALE	DESIGN UNITS	THIRD ANGLE PROJECTION
	mm	INCH	---	INCH	
4 PLACES ±---	±---	±---	DRAWN BY	DATE	TITLE
3 PLACES ±---	±---	±005	RSTONE	2014/07/17	SR BTS WW ASSY .375 PITCH WITH MOUNTING ENDS
2 PLACES ±0.13	±0.1	---	CHECKED BY	DATE	
1 PLACE ±0.3	±---	---	BARDEN	---	MOLEX INCORPORATED
ANGULAR ±---		---	APPROVED BY	DATE	
DRAFT WHERE APPLICABLE MUST REMAIN WITHIN DIMENSIONS		JFMURPHY		2014/08/02	MOLEX INCORPORATED
MATERIAL NO. SEE PART LEGEND		DOCUMENT NO.		SD-38721-010	
SIZE C		THIS DRAWING CONTAINS INFORMATION THAT IS PROPRIETARY TO MOLEX INCORPORATED AND SHOULD NOT BE USED WITHOUT WRITTEN PERMISSION			
		SHEET NO.		1 OF 1	