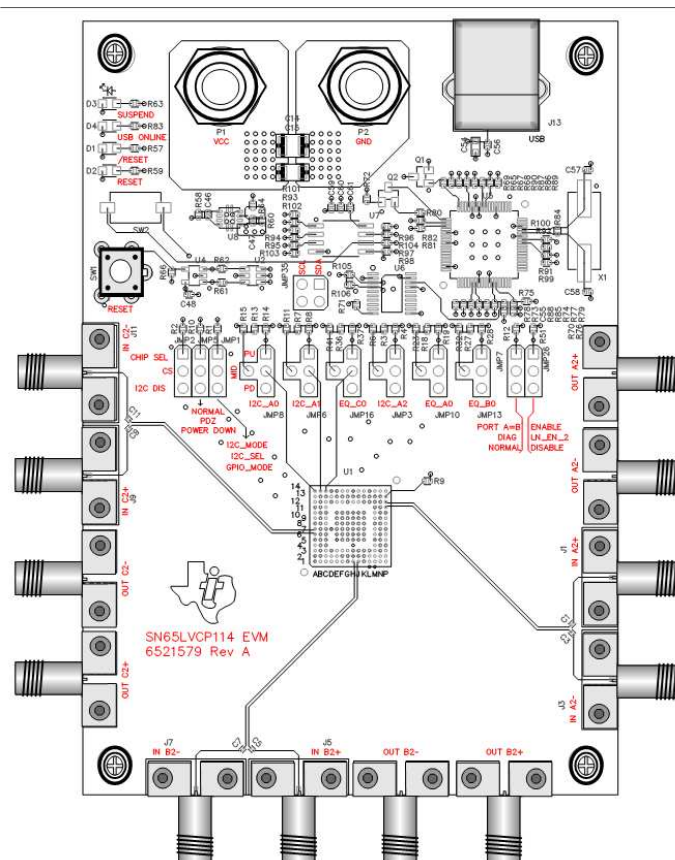


SN65LVCP114 Evaluation Module (EVM)

The Texas Instruments SN65LVCP114 Evaluation Module (EVM) board is used to evaluate the SN65LVCP114, 14.2Gbps Quad 1:2-2:1 Mux, Linear-Redriver with Signal Conditioning. This document provides guidance on the device's proper use by showing some operating configurations and test modes. The EVM board schematic and layout information are also provided for the customer. Information in this guide assists the customer in choosing the optimal design methods and materials in designing a complete system.



WARNING

This equipment is intended for use in a laboratory test environment only. It generates, uses, and can radiate radio frequency energy and has not been tested for compliance with the limits of computing devices, pursuant to subpart J, part 15 of FCC rules. These rules are designed to provide reasonable protection against radio frequency interference. Operation of this equipment in other environments may cause interference with radio communications, in which case the user, at their own expense, must take whatever measures are necessary to correct this interference.

Contents

1	Introduction	3
2	EVM PCB and High-Speed Design Considerations	3
3	SN65LVCP114 EVM Kit Contents	3
4	SN65LVCP114 EVM Board Configuration	4
5	Test Setup	5
6	I2C Mode	6
7	GPIO Mode	6
8	Schematics	8
9	Bill of Materials	16
10	Board Layout	18
Appendix A	Jumper Shunt Settings	25
Appendix B	Typical Evaluation Setups	25

List of Figures

1	SN65LVCP114 EVM	4
2	SN65LVCP114 EVM Jumper Description	5
3	SN65LVCP114 EVM Schematic, Port A	8
4	SN65LVCP114 EVM Schematic, Port B	9
5	SN65LVCP114 EVM Schematic, Port C	10
6	SN65LVCP114 EVM Schematic, Controls_1	11
7	SN65LVCP114 EVM Schematic, Controls_2	12
8	SN65LVCP114 EVM Schematic, Controls_3	13
9	SN65LVCP114 EVM Schematic, Power Distribution	14
10	SN65LVCP114 EVM Schematic, USB Interface	15
11	SN65LVCP114 EVM PCB Layer Construction	18
12	SN65LVCP114 Board Layout: Top Signal (Layer 1 of 6)	19
13	SN65LVCP114 Board Layout: Internal Ground (Layer 2 of 6)	20
14	SN65LVCP114 Board Layout: Internal Power (Layer 3 of 6)	21
15	SN65LVCP114 Board Layout: Internal Signal (Layer 4 of 6)	22
16	SN65LVCP114 Board Layout: Internal Ground (Layer 5 of 6)	23
17	SN65LVCP114 Board Layout: Bottom Signal (Layer 6 of 6)	24
18	Receive Side Use Case	25
19	Transmit Side Use Case	26
20	Combined Bus Extension Use Case	26

List of Tables

1	SN65LVCP114 EVM Pin and Jumper Functionality	5
---	--	---

2	SN65LVCP114 EVM I2C Mode Settings	6
3	SN65LVCP114 EVM Jumper and EQ Settings	6
4	SN65LVCP114 EVM GPIO Mode Settings	7
5	SN65LVCP114 EVM Bill of Materials	16

1 Introduction

The Texas Instruments (TI) SN65LVCP114 is a 14.2Gbps asynchronous, protocol-agnostic, low-latency QUAD 1:2-2:1 mux, linear-redriver switch with signal conditioning. The device linearly compensates for channel loss in backplane and active-cable applications. The architecture of the SN65LVCP114 crosspoint switch is designed to work effectively with ASIC or FPGA products implementing digital equalization by using decision feedback equalizer (DFE) technology. SN65LVCP114 mux, linear-redriver switch preserves the integrity (composition) of the received signal ensuring optimum DFE and system performance. SN65LVCP114 provides low-power mux, linear-redriver solution while at the same time extending the effectiveness of DFE.

2 EVM PCB and High-Speed Design Considerations

The EVM and the contents of this guide are used to evaluate device parameters in addition to helping with high-speed board layout. As the frequency of operation increases, the board designer must take special care to ensure that the highest signal integrity is maintained. To achieve this, the board's impedance is controlled to 50 Ω single-ended or 100 Ω differential impedance for both the low and high-speed differential serial and clock connections. The use of vias is minimized and, when necessary, are designed to minimize impedance discontinuities along the transmission line. Care was taken to control trace length mismatch (board skew) to less than ± 0.1 MIL.

The board layout is designed and optimized to support high-speed operation. Understanding impedance control and transmission line effects is crucial when designing high-speed boards. Some of the advanced features offered by this board include:

- SN65LVCP114 printed circuit board (PCB) designed for optimal high-speed signal integrity using Rogers Material for the outer signal layers and FR-4 for the inner layers. All Gigabit signals are routed over the Rogers Material for minimal signal loss.
- SMA and header fixtures are easily connected to test equipment.
- All input/output signals are accessible for rapid prototyping.
- On-board capacitors provide AC coupling of high-speed transmit and receive signals.

3 SN65LVCP114 EVM Kit Contents

The SN65LVCP114 EVM kit contains the following:

- SN65LVCP114 EVM board
- SN65LVCP114 EVM User's Guide (this document)
- SN65LVCP114 datasheet
- CD-ROM containing the graphical user interface (GUI) software

4 SN65LVCP114 EVM Board Configuration

The SN65LVCP114 is operated from a 2.5-V or 3.3-V power supply with a 1.0 A or greater current rating. The SN65LVCP114 has three ports; each port has four lanes. The switch logic of the SN65LVCP114 is implemented to support 2:1 MUX per lane, 1:2 DEMUX per lane, and independent lane switching. Each of the ports are independently programmed for receive equalization. The device also supports loopback on all three ports.

The EVM provides SMA connections for one lane per port for device evaluation with full configuration control of the device through I2C using the SN65LVCP114 GUI provided. Limited configuration control is available through GPIO. Refer to [Section 7](#) for more details.

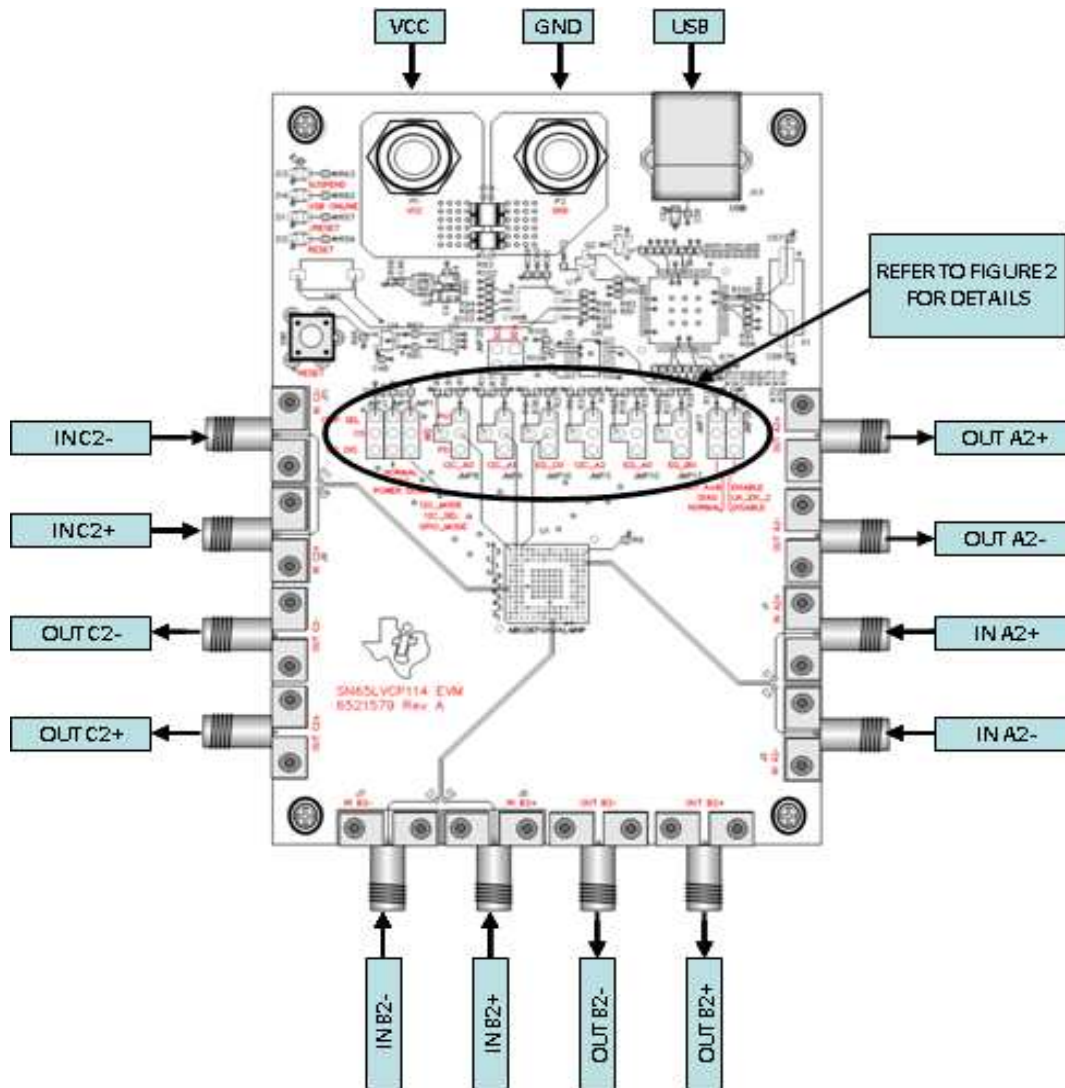


Figure 1. SN65LVCP114 EVM

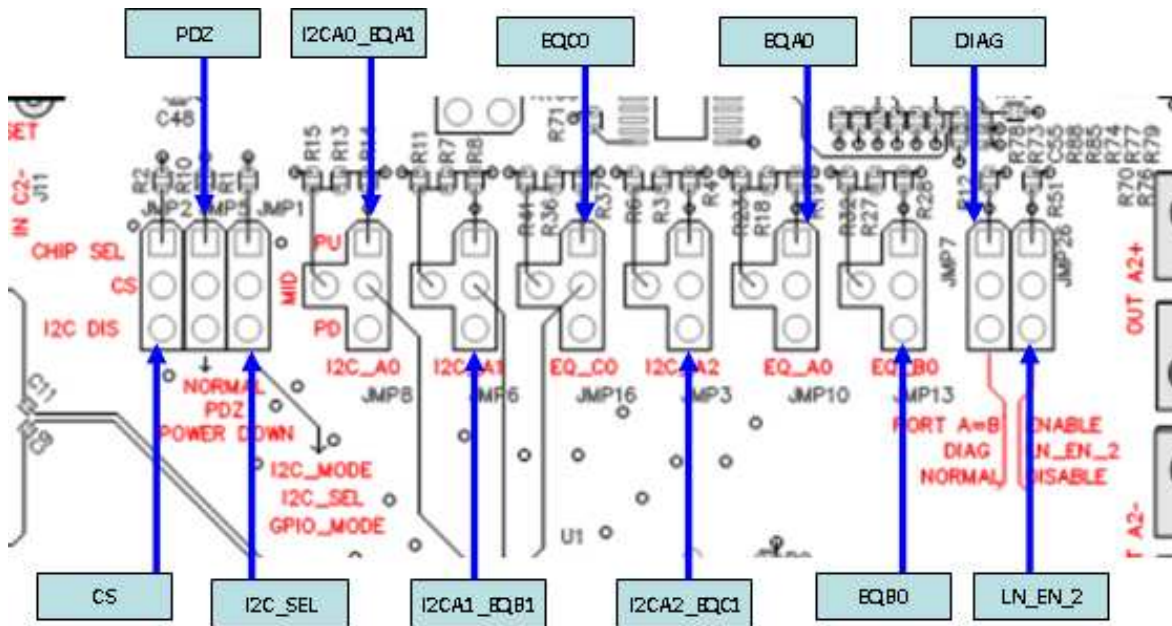


Figure 2. SN65LVCP114 EVM Jumper Description

5 Test Setup

The SN65LVCP114 EVM gives the developer two control interface options for operation, I2C or GPIO mode. Input and Output differential pairs are available through edge-launch SMAs with approximately 2.5 inches of trace with Rogers Low-Dielectric material with 0.1 μ F AC Coupling capacitors. Power to the device, VCC, is applied using banana jacks (P1, P2). The USB-to-I2C circuitry on the board uses power from the USB 5-V signal.

Table 1. SN65LVCP114 EVM Pin and Jumper Functionality

Ref Des	Symbol	Description	
		GPIO mode	I2C mode
J1, J3	AINP2, AINN2	Differential input, lane 2, Fabric switch A side	
J2, J4	AOUTP2, AOUTN2	Differential output, lane 2, Fabric switch A side	
J5, J7	BINP2, BINN2	Differential input, lane 2, Fabric switch B side	
J6, J8	BOUTP2, BOUTN2	Differential output, lane 2, Fabric switch B side	
J9, J11	CINP2, CINN2	Differential input, lane 2, Fabric switch C side	
J10, J12	COU2P2, COU2N2	Differential output, lane 2, Fabric switch C side	
P1	VCC	Banana jack, positive power supply connection	
P2	GND	Banana jack, ground power supply connection	
J13	USB	USB cable connection	
JMP2	CS	Don't Care	High, acts as Chip Select Low, disables the I2C interface
JMP5	PDZ	High, normal operation Low, powers down the device, inputs off and outputs disabled, resets the I2C	
JMP1	I2C_SEL	Configures the device in I2C or GPIO mode of operation High, enables I2C mode Low, enables GPIO mode	
JMP8	I2C_A0_EQA1	3 level control for EQ gain of port A	I2C Address
JMP6	I2C_A1_EQB1	3 level control for EQ gain of port B	I2C Address
JMP16	EQ_C0	3 level control for EQ gain of port C	Don't care
JMP3	I2C_A2_EQC1	3 level control for EQ gain of port C	I2C Address

Table 1. SN65LVCP114 EVM Pin and Jumper Functionality (continued)

Ref Des	Symbol	Description	
		GPIO mode	I2C mode
JMP10	EQ_A0	3 level control for EQ gain of port A	Don't care
JMP13	EQ_B0	3 level control for EQ gain of port B	Don't care
JMP7	DIAG	High, enables the same data on the line side (Port C) to be output on both fabric side ports (Port A & B) Low, normal operation	Don't care
JMP26	LN_EN_2	High, enables lane 2 of ports A, B & C	Don't care

6 I2C Mode

The I2C mode is implemented using the SN65LVCP114 user interface software included in the CD-ROM with the EVM. Refer to the SN65LVCP114 EVM GUI User's Guide for details on how to use the GUI.

[Table 2](#) shows the appropriate jumper settings on the EVM to configure the device in I2C mode. Refer to [Appendix A](#) for jumper shunt settings.

See the SN65LVCP114 Datasheet for a detailed description of the register map.

Table 2. SN65LVCP114 EVM I2C Mode Settings

Ref Des	Symbol	I2C Mode Pin Settings
JMP8	I2C_A0_EQA1	Low
JMP6	I2C_A1_EQB1	Low
JMP3	I2C_A2_EQC1	Low
JMP5	PDZ	High, normal operation Low, powers down the device, inputs off and outputs disabled, resets the I2C
JMP1	I2C_SEL	Configures the device in I2C or GPIO mode of operation High, enables I2C mode

7 GPIO Mode

Although it is recommended to use the EVM in I2C mode so that the user has full control of the device some control of the SN65LVCP114 device is available on the EVM through GPIO mode. Refer to [Table 3](#) for the different jumper and EQ settings. [Table 4](#) shows the appropriate jumper and default settings on the EVM to configure and control the device in GPIO mode. Refer to [Appendix A](#) for jumper shunt settings.

See the SN65LVCP114 Datasheet for a detailed description of the control signals.

Table 3. SN65LVCP114 EVM Jumper and EQ Settings

EQ[x]0	EQ[x]1	Peaking in dB
0	0	1.3
0	HiZ	2
0	1	3.6
HiZ	0	5
HiZ	HiZ	6.5
HiZ	1	8.3
1	0	10
1	HiZ	11.9
1	1	13.9

Table 4. SN65LVCP114 EVM GPIO Mode Settings

Ref Des	Symbol	GPIO Mode Pin Description
JMP8	I2C_A0_EQA1	3 level control for EQ gain of port A
JMP6	I2C_A1_EQB1	3 level control for EQ gain of port B
JMP3	I2C_A2_EQC1	3 level control for EQ gain of port C
JMP10	EQ_A0	3 level control for EQ gain of port A
JMP13	EQ_B0	3 level control for EQ gain of port B
JMP16	EQ_C0	3 level control for EQ gain of port C
	LPA	Default setting, Loopback disabled
	LPB	Default setting, Loopback disabled
	LPC	Default setting, Loopback disabled
	SEL0	Default setting, port B is selected on Lane 0
	SEL1	Default setting, port B is selected on Lane 1
	SEL2	Default setting, port B is selected on Lane 2
	SEL3	Default setting, port B is selected on Lane 3
JMP2	CS	Don't Care
JMP5	PDZ	High, normal operation Low, powers down the device, inputs off and outputs disabled, resets the I2C
JMP7	DIAG	High, enables the same data on line side (Port C) to be output on both fabric side ports (Port A & B) Low, normal operation
	LN_EN_0	Default setting, lane 0 of ports A, B & C are disabled
	LN_EN_1	Default setting, lane 1 of ports A, B & C are disabled
JMP26	LN_EN_2	High, enables lane 2 of ports A, B & C Low, disables lane 0 of ports A, B & C
	LN_EN_3	Default setting, lane 3 of ports A, B & C are disabled
	DIS_AGC_A	Default setting, AGC loop enable
	DIS_AGC_B	Default setting, AGC loop enable
	DIS_AGC_C	Default setting, AGC loop enable
	VOD_A	Default setting; VOD output range = 600 mV
	VOD_B	Default setting; VOD output range = 600 mV
	VOD_C	Default setting; VOD output range = 600 mV
	GAIN_A	Default setting; Receiver Gain = 0.5
	GAIN_B	Default setting; Receiver Gain = 0.5
	GAIN_C	Default setting; Receiver Gain = 0.5
	FST_SW	Default setting; fast switching, the idle outputs are squelched
JMP1	I2C_SEL	Configures the device in I2C or GPIO mode of operation High, enables I2C mode Low, enables GPIO mode

8 Schematics

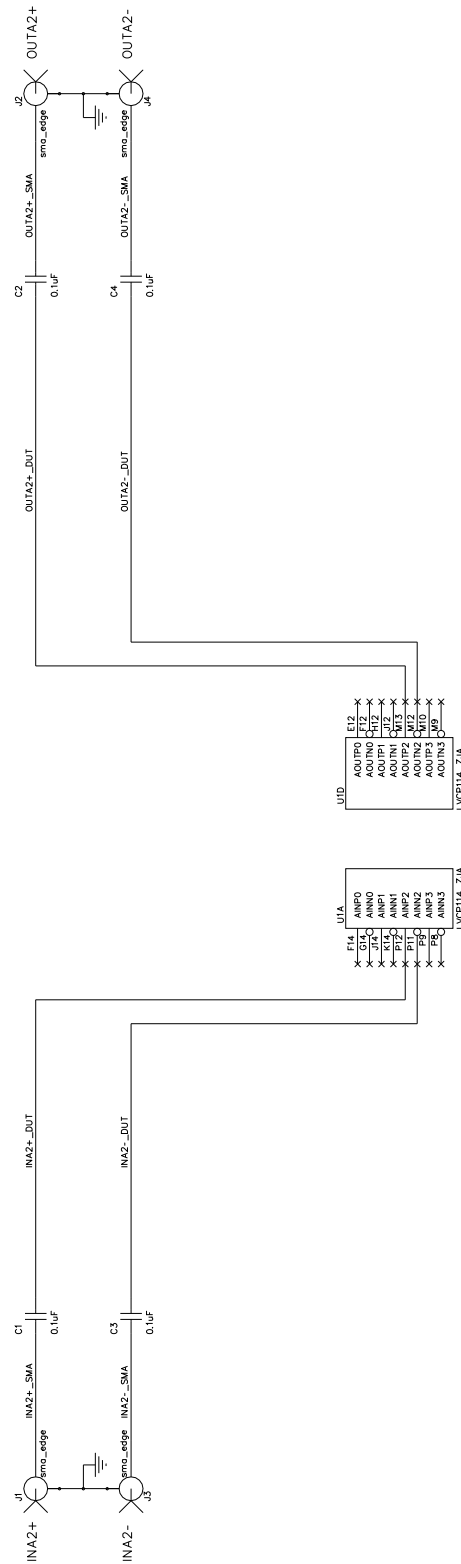


Figure 3. SN65LVCP114 EVM Schematic, Port A

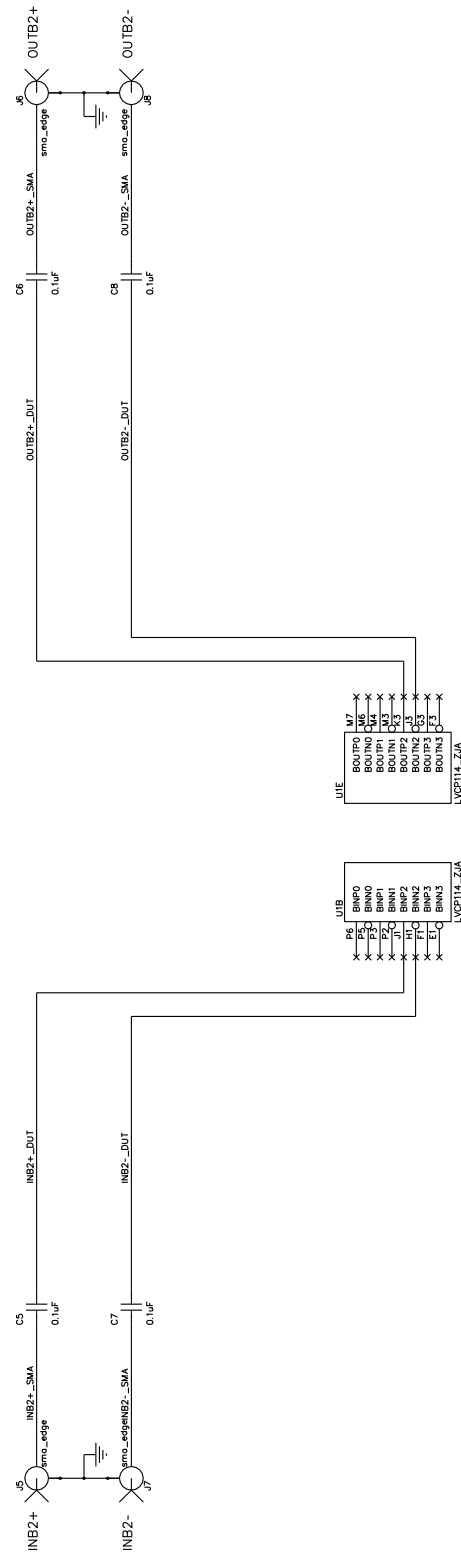
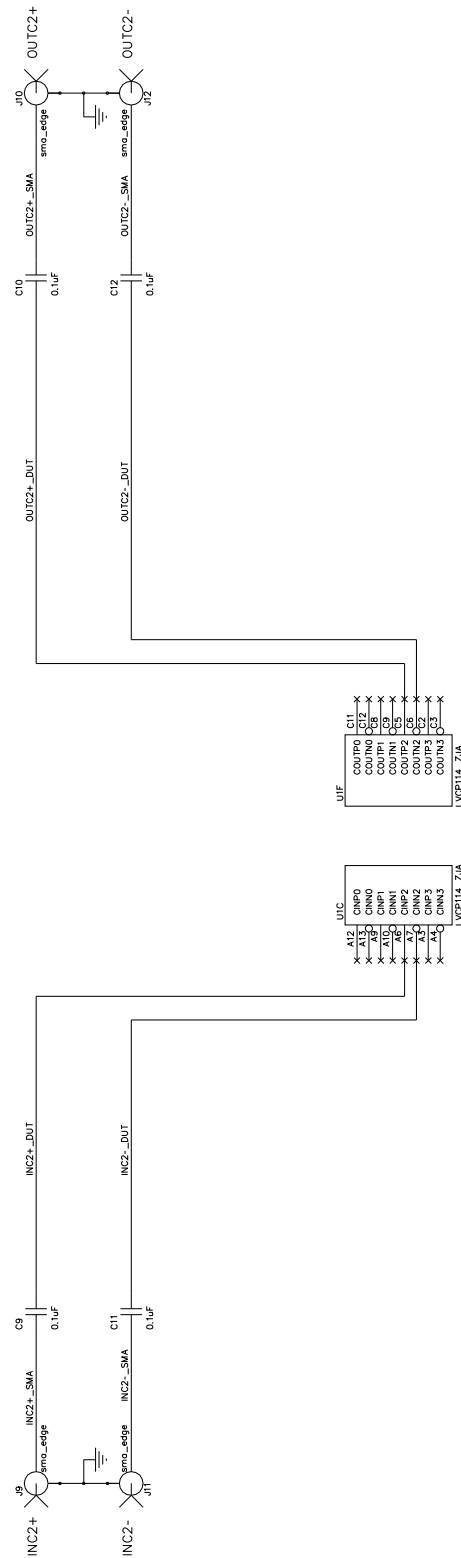


Figure 4. SN65LVCP114 EVM Schematic, Port B



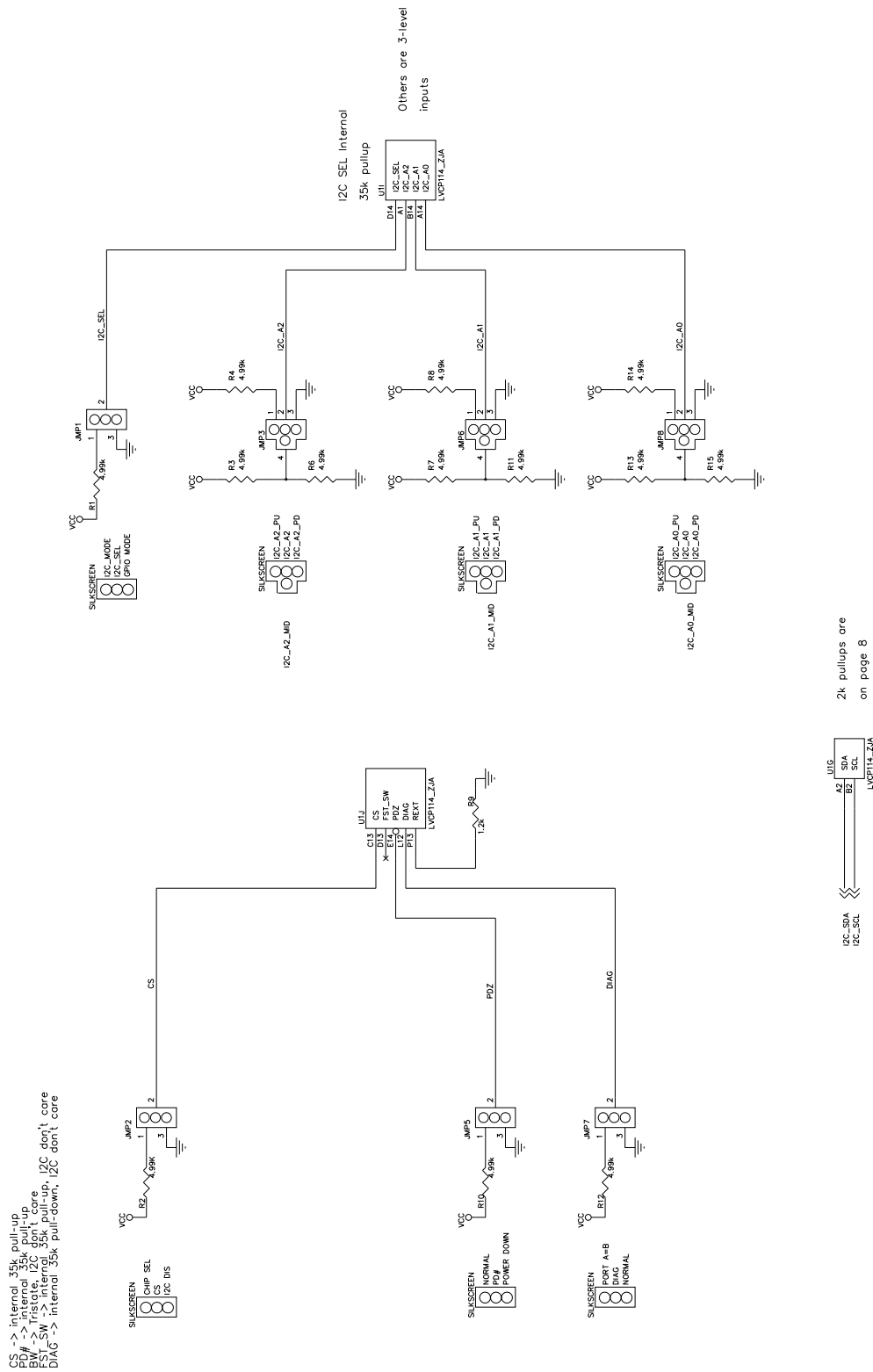


Figure 6. SN65LVCP114 EVM Schematic, Controls_1

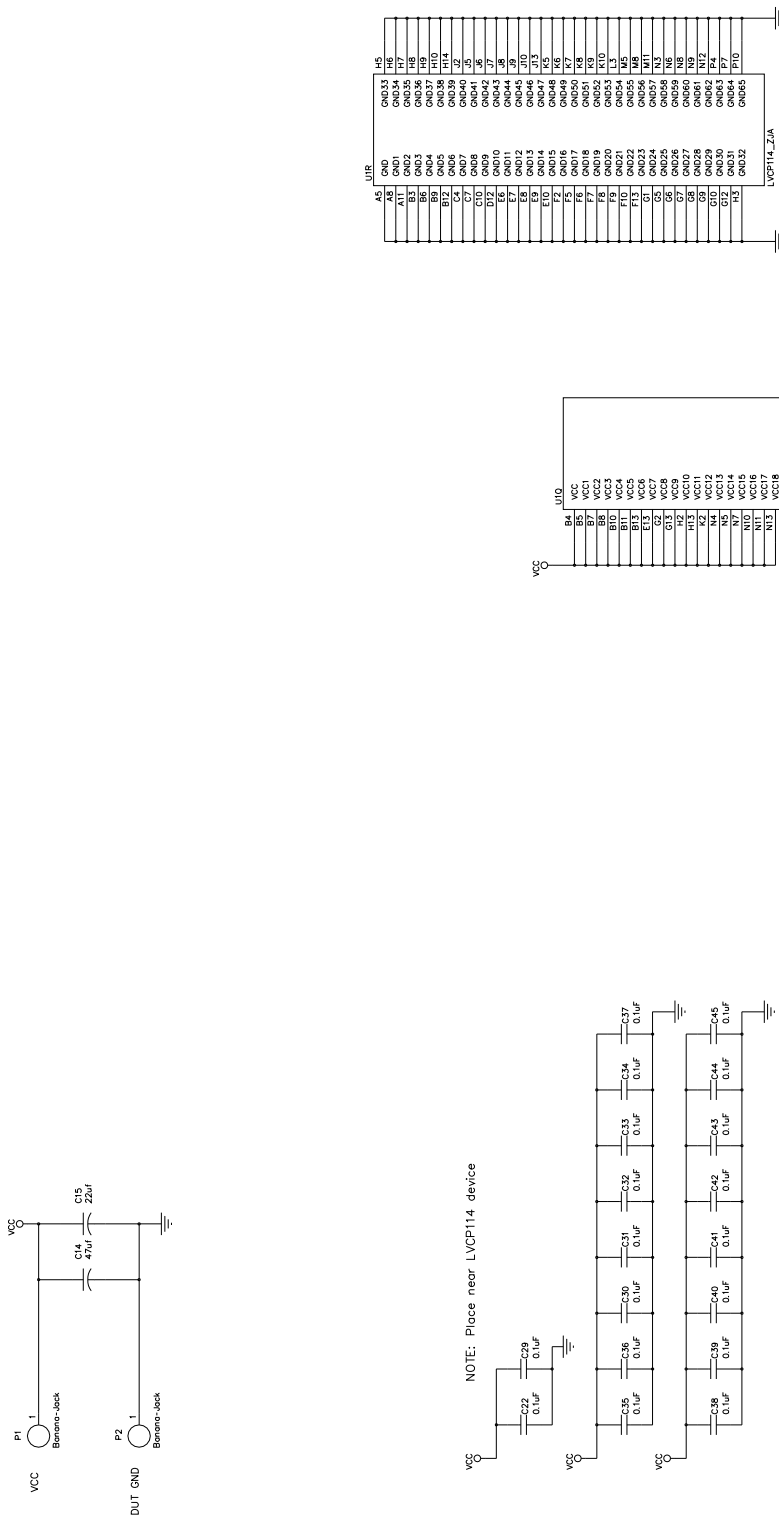


Figure 9. SN65LVCP114 EVM Schematic, Power Distribution

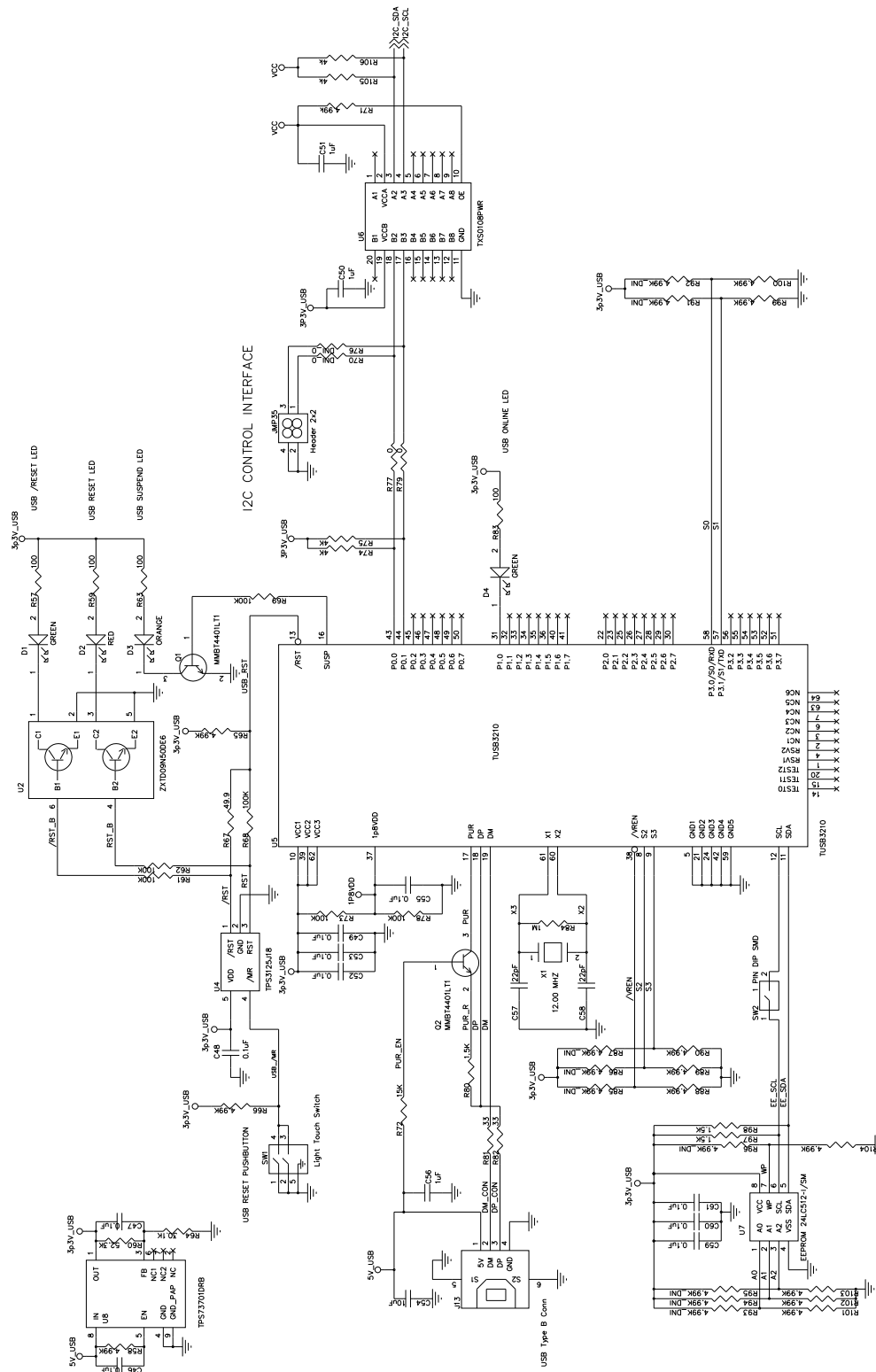


Figure 10. SN65LVCP114 EVM Schematic, USB Interface

9 Bill of Materials
Table 5. SN65LVCP114 EVM Bill of Materials

Reference	Value	Part	Part Number	Manufacturer
C1–C12, C22, C29–C45	0.1 μ F	0201 CAP	LMK063BJ104KP-F	Taiyo Yuden
C14	47 μ F	1210 CAP	EMK325BJ476MM-T	Taiyo Yuden
C15	22 μ F	1206 CAP	EMK316BJ226ML-T	Taiyo Yuden
C46–C49, C52, C53, C55, C59–C61	0.1 μ F	0402 CAP	C1005X5R1E104K	TDK Corporation
C50, C51, C56	1 μ F	0402 CAP	LMK105BJ105KV-F	Taiyo Yuden
C54	10 μ F	0603 CAP	C1608X5R1A106M	TDK Corporation
C57, C58	22 pF	0402 CAP	C0402COG500-220JNE	Venkel
D1, D4	LED - GREEN	C170	HSMG-C170	Avago Technologies
D2	LED - RED	C170	SML-LXT0805IW-TR	Lumex Opto/Components
D3	LED - ORANGE	C170	HSMD-C170	Avago Technologies
JMP1, JMP2, JMP5, JMP7, JMP26	1 X 3	0.1"	HTSW-150-08-G-S	Samtec
JMP3, JMP6, JMP8, JMP10, JMP13, JMP16	1 X 4 T	0.1"	HTSW-150-08-G-S	Samtec
JMP35	2 X 2	0.1x0.1"	HTSW-150-08-G-D	Samtec
J1–J12	Edge Mount SMA	CON_02K243-40M	32K243-40ML5	Rosenberger
J13	USB - B Type	B Type	USB-B-S-F-B-TH	Samtec
P1, P2	Banana Plug - Metal	4 mm	108-0740-001	Emerson Network Power
Q1, Q2	NPN	SOT23	MMBT4401	Fairchild Semiconductor
R1–R4, R6–R8, R10–R15, R18, R19, R23, R27, R28, R32, R36, R37, R41, R51, R58, R65, R66, R71, R88–R90, R99–R104	4.99 K Ω	0402 RES	RG1005P-4991-B-T5	Susumu Co., Ltd.
R9	1.2 K Ω	0402 RES	ERJ-XGNJ122Y	Panasonic - ECG
R57, R59, R63, R83	100 Ω	0402 RES	RC0402FR-07100RL	Yageo
R60	52.3 K Ω	0402 RES	ERJ-2RKF5232X	Panasonic - ECG
R61, R62, R68, R69, R73, R78	100 K Ω	0402 RES	RC0402FR-07100KL	Yageo
R64	30.1 K Ω	0402 RES	ERJ-2RKF3012X	Panasonic - ECG
R67	49.9 Ω	0402 RES	RC0402FR-0749R9L	Yageo
R70, R76	DNI_0 Ω	0402 RES	ERJ-2GE0R00X	Panasonic - ECG
R72	15 K Ω	0402 RES	ERJ-2RKF1502X	Panasonic - ECG
R74, R75, R105, R106	4.02 K Ω	0402 RES	CRCW04024K02FKED	Vishay/Dale
R77, R79	0.0 (Zero Ohm)	0402 RES	RC0402JR-070RL	Yageo
R80, R97, R98	1.5 K Ω	0402 RES	RG1005P-152-B-T5	Susumu Co., Ltd.

Table 5. SN65LVCP114 EVM Bill of Materials (continued)

Reference	Value	Part	Part Number	Manufacturer
R81, R82	33 Ω	0402 RES	RR0510R-330-D	Susumu Co., Ltd.
R84	1 MΩ	0402 RES	RMCF0402FT1M00	STACKPOLE ELEC. INC.
R85–R87, R91–R96	4.99 KΩ_DNI	0402 RES	RG1005P-4991-B-T5	Susumu Co., Ltd.
SW1	Momentary Push-Button Switch	6.00 mm x 6.00 mm	EVQ-PBE05R	Panasonic - ECG
SW2	1 PIN DIP SMD	SMT	SDA01H0SB	ITT Cannon - C&K
U1	LVCP114_ZJA	197pin_0.8 mm pitch BGA	SN65LVCP114ZJA	Texas Instruments
U2	DUAL NPN	SOT-23-6	ZXTD09N50DE6TA	Zetex Inc
U4	Voltage Supervisor with Manual Reset	SOT-23-5	TPS3125J18DBVR	Texas Instruments
U5	USB Microcontroller	64-LQFP	TUSB3210PM	Texas Instruments
U6	Bidirectional Level Shifter	20-TSSOP	TXB0108PWR	Texas Instruments
U7	512Kb EEPROM	8-SOIC	24LC512-I/SM	Microchip Technology
U8	Single Output LDO	8-SON	TPS73701DRB	Texas Instruments
X1	12.00 MHz Crystal	SMD	ECS-120-32-5PVX	ECS Inc
	#4-40 Machine Screw		H703-ND	Digikey
	#4-40 Rounded Thread		2029K-ND	Digikey

10 Board Layout

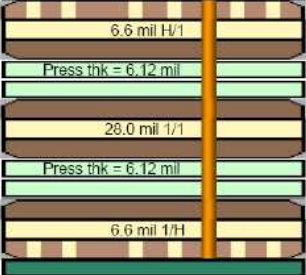
Layer	Type	CU Weight	CU %	Material Description	Via Structure	Segment	Class Style	Material Family	Dielectric constant	Thickness After lamination [mil]
Soldermask										
L1	Signal	H	20	6.6 mil H/1		Core		RO4350B/RO4450B	3.7	0.80
L2	Plane	1.0	100	Press thk = 6.12 mil		Prepreg	2113(58) 1080(65)	PCL-370HR PCL-370HR	3.9 3.9	6.60 1.20
L3	Plane	1.0	60	28.0 mil 1/1		Core		PCL-370HR	3.9	1.20
L4	Plane	1.0	60	Press thk = 6.12 mil		Prepreg	1080(65) 2113(58)	PCL-370HR PCL-370HR	3.9 3.9	1.20 6.12
L5	Plane	1.0	100	6.6 mil 1/1		Core		RO4350B/RO4450B	3.7	1.20
L6	Signal	H	20	6.6 mil 1/1		Core		RO4350B/RO4450B	3.7	6.60 2.00
Soldermask										
Specification (Over mask on plated copper):					mil					
Overall Board Thickness:					64.0		Anticipated Board Thickness:			
Tolerance:					+6.4/-6.4		After lamination:			
Min-Max Board Thickness:					57.6 - 70.4		Over mask on plated copper:			
							63.8			

Figure 11. SN65LVCP114 EVM PCB Layer Construction

NOTE: Always consult your board manufacturer for their process/design requirements to ensure the desired impedance is achieved.

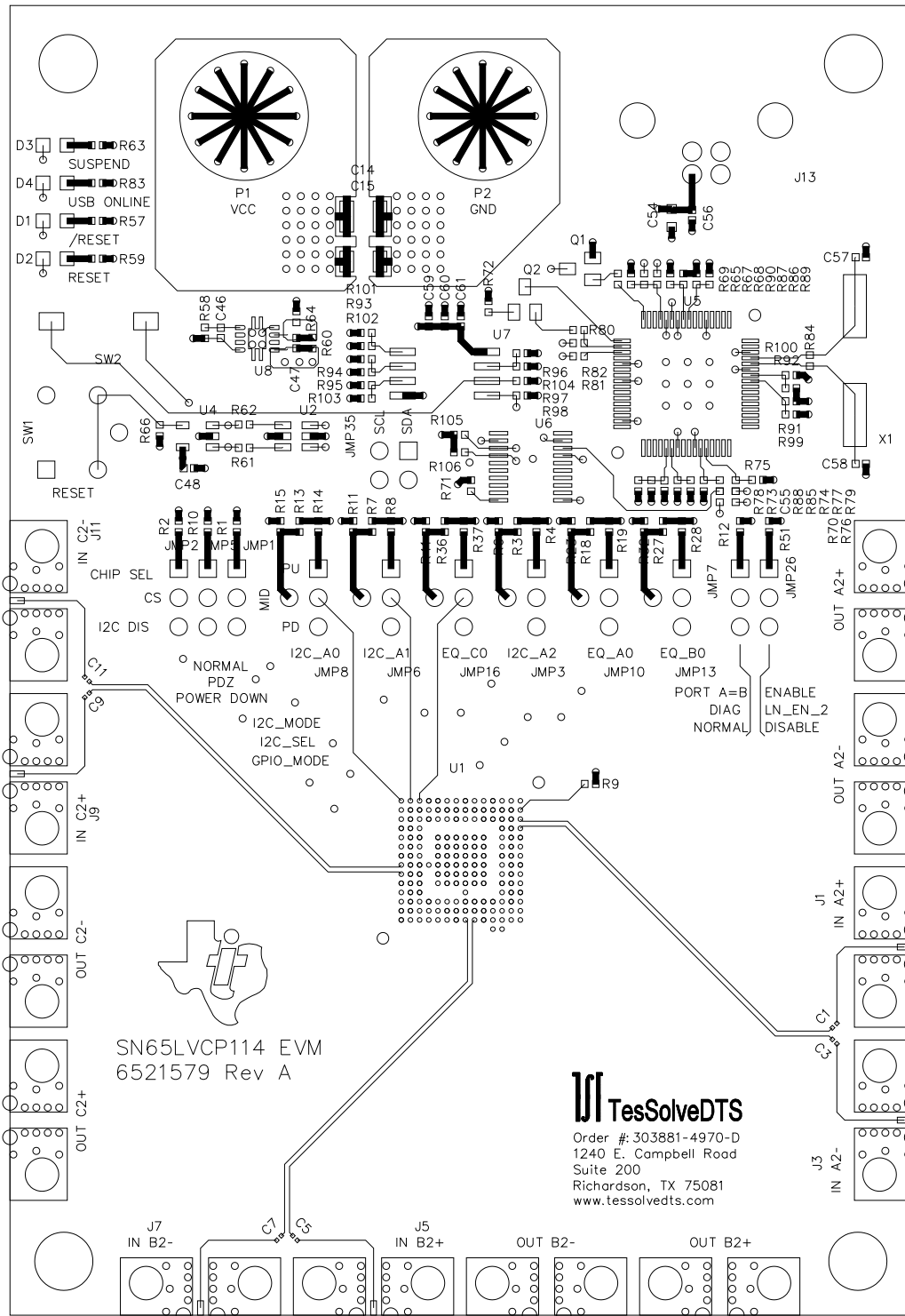


Figure 12. SN65LVCP114 Board Layout: Top Signal (Layer 1 of 6)

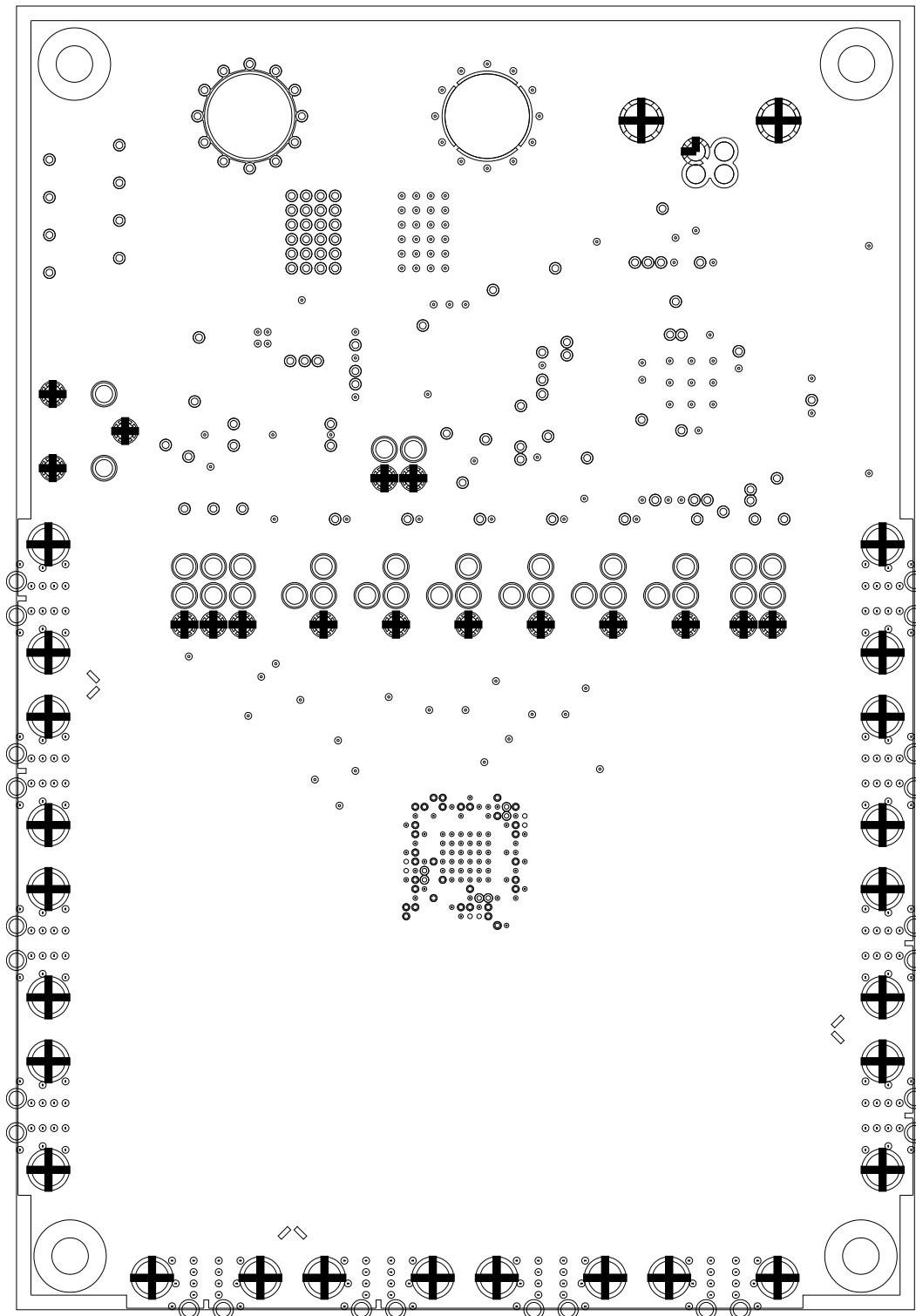


Figure 13. SN65LVCP114 Board Layout: Internal Ground (Layer 2 of 6)

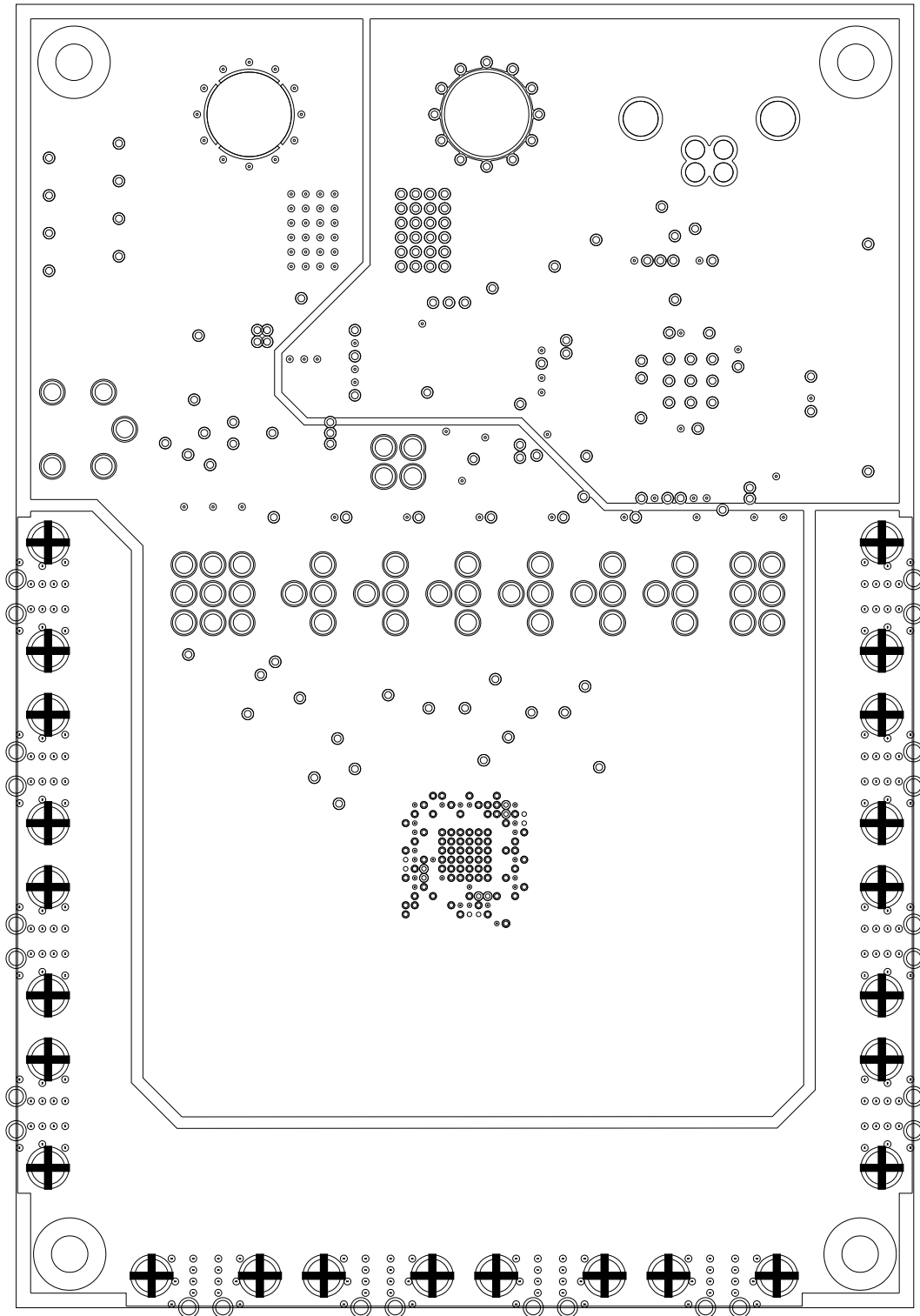


Figure 14. SN65LVCP114 Board Layout: Internal Power (Layer 3 of 6)

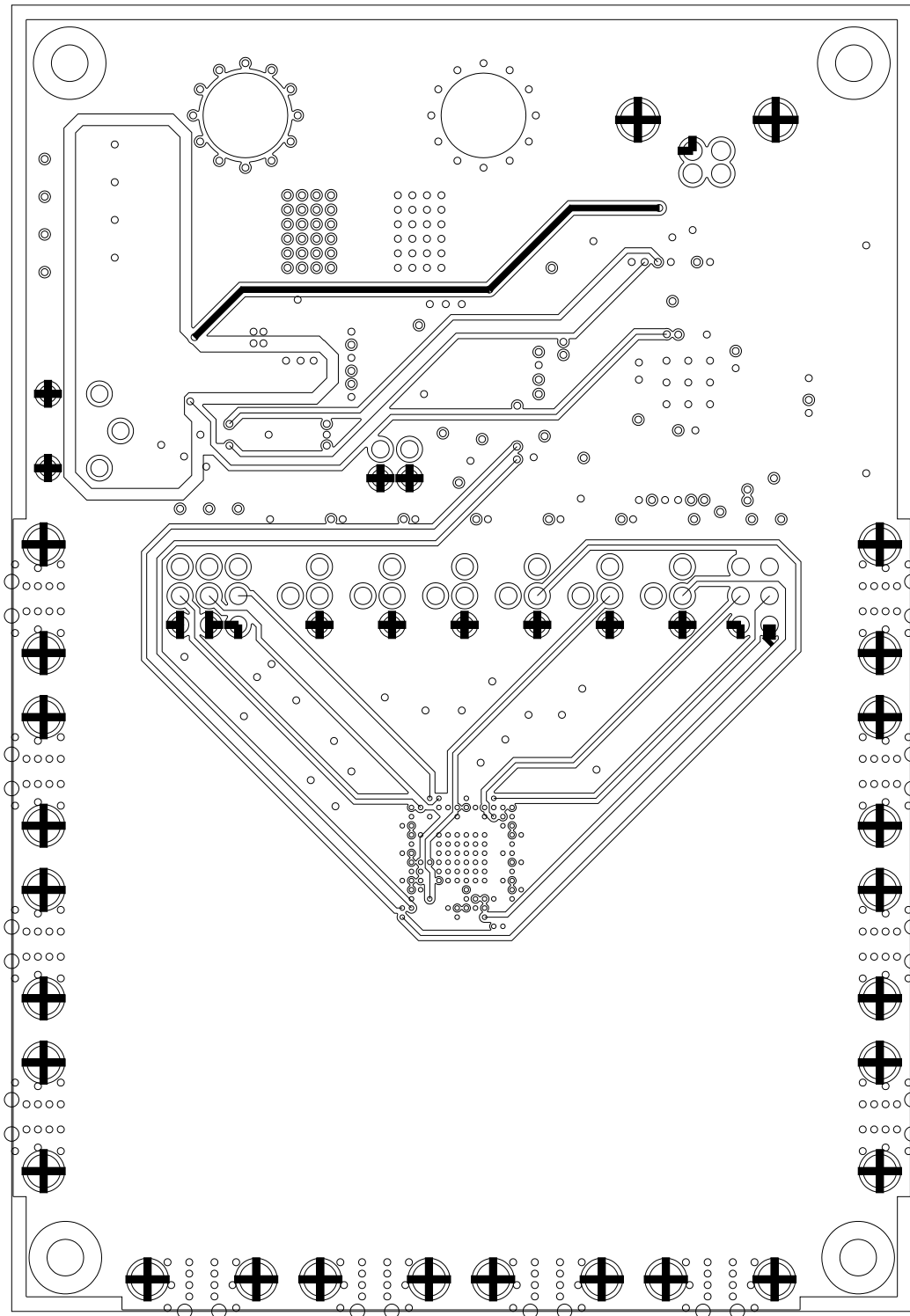


Figure 15. SN65LVCP114 Board Layout: Internal Signal (Layer 4 of 6)

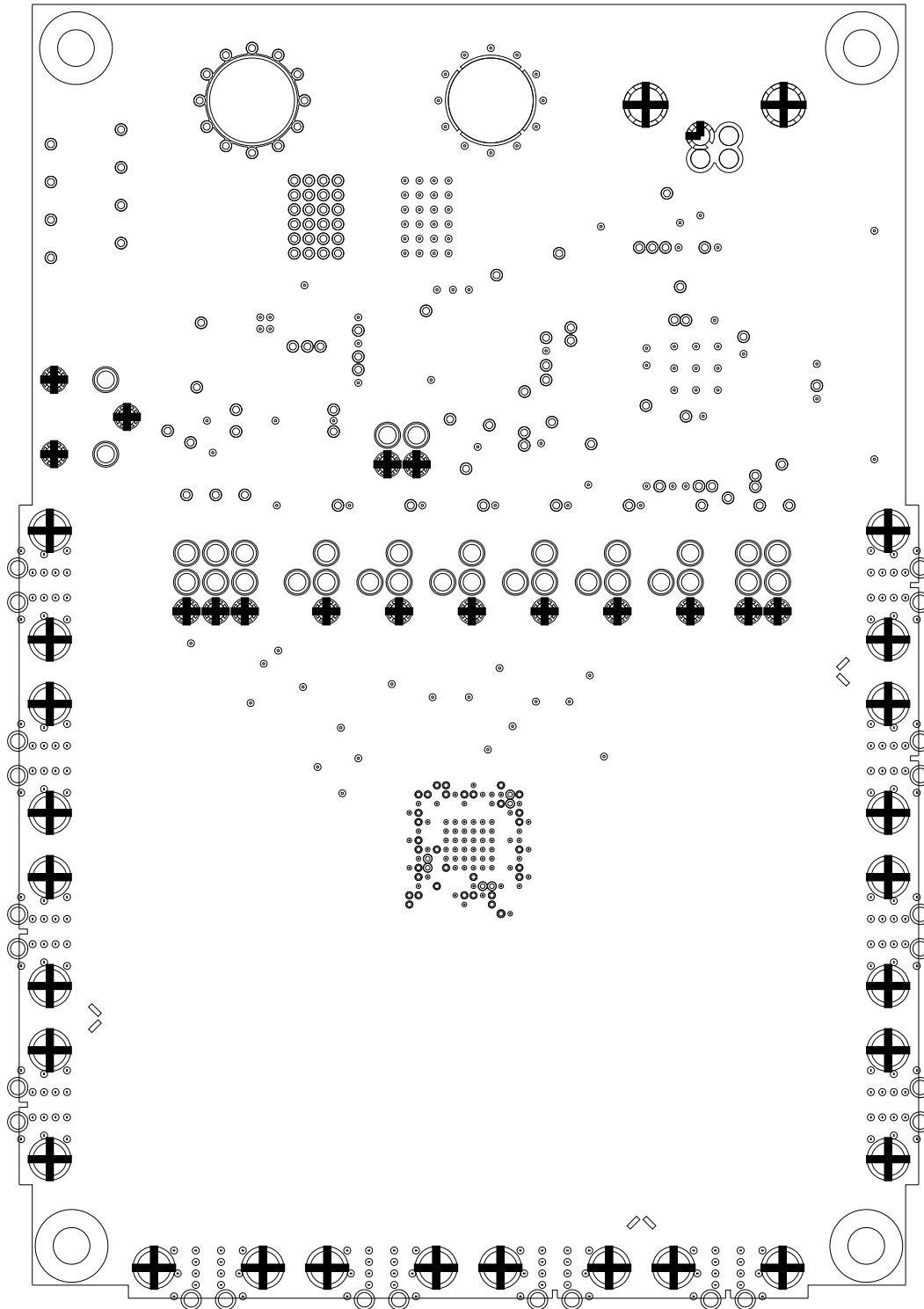


Figure 16. SN65LVCP114 Board Layout: Internal Ground (Layer 5 of 6)

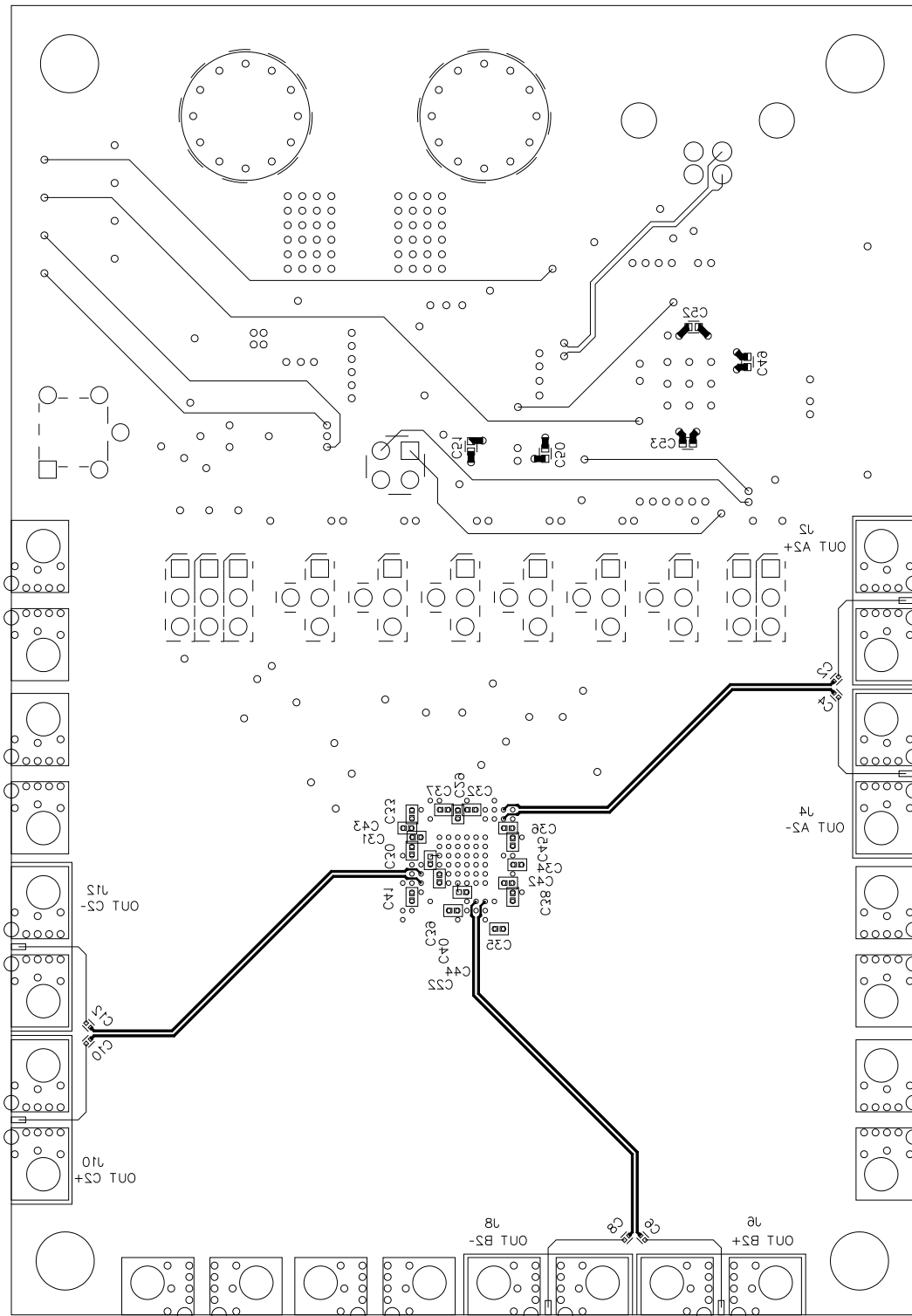







Figure 17. SN65LVCP114 Board Layout: Bottom Signal (Layer 6 of 6)

Appendix A Jumper Shunt Settings

The table below shows the different shunt settings of the 3 and 4 pin jumpers on the EVM.

Shunt Setting	Description
	High
	HiZ
	Low
	High
	Low

Appendix B Typical Evaluation Setups

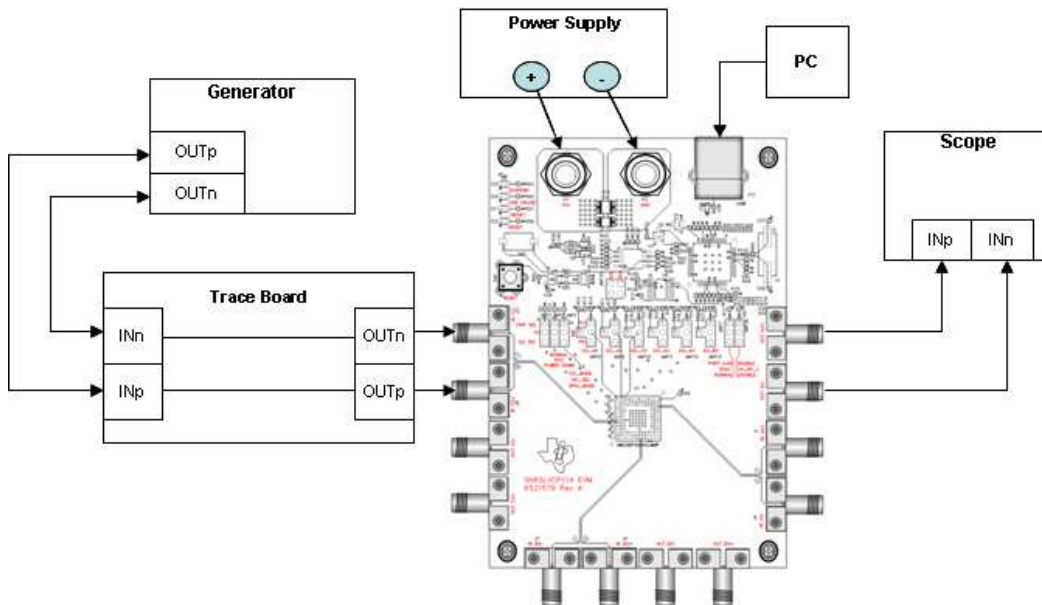


Figure 18. Receive Side Use Case

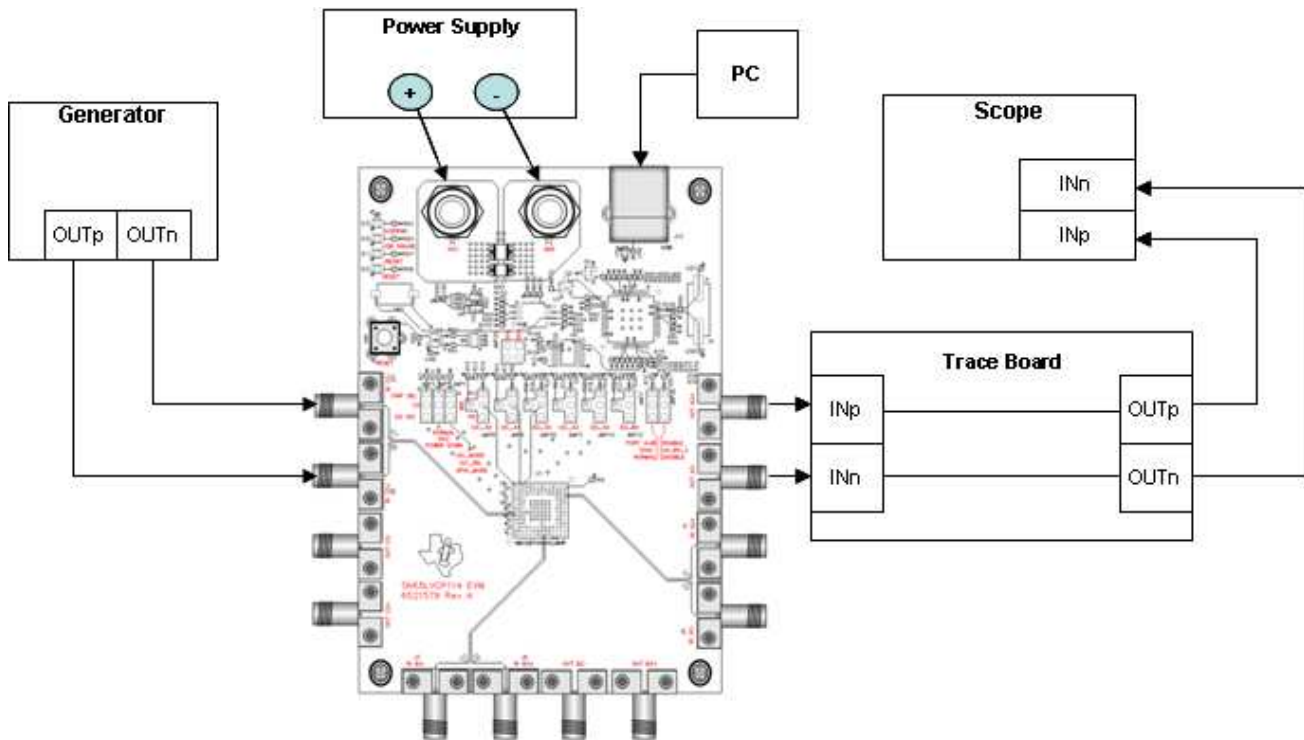


Figure 19. Transmit Side Use Case

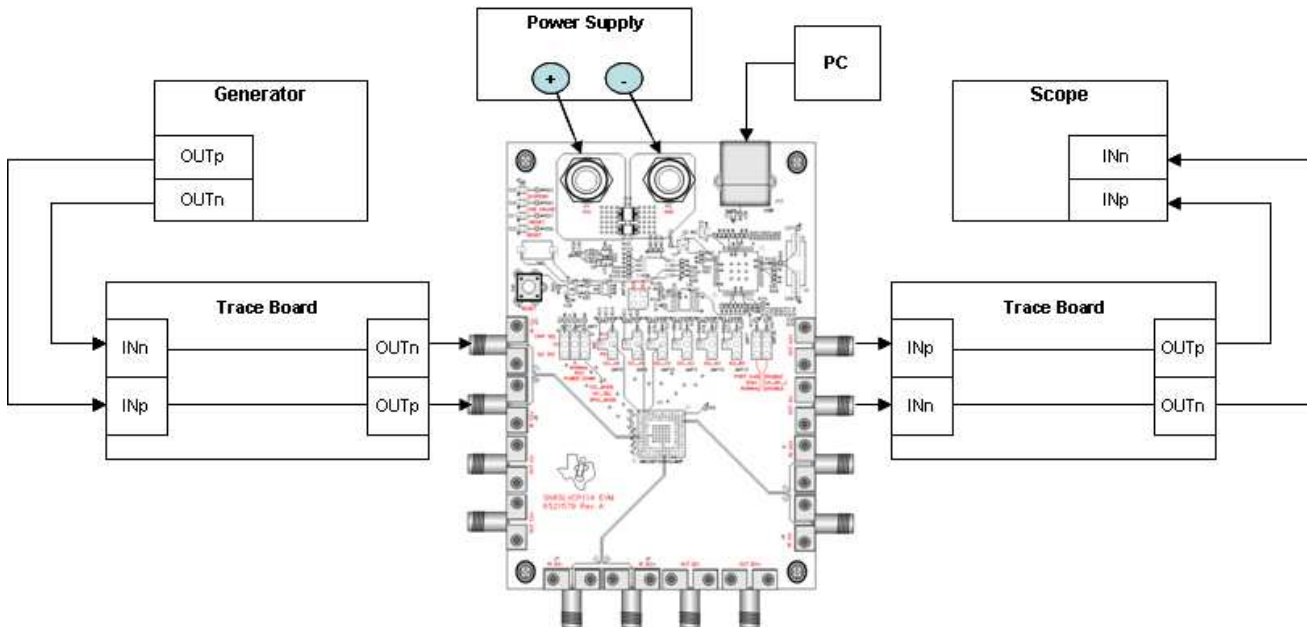


Figure 20. Combined Bus Extension Use Case

EVALUATION BOARD/KIT/MODULE (EVM) ADDITIONAL TERMS

Texas Instruments (TI) provides the enclosed Evaluation Board/Kit/Module (EVM) under the following conditions:

The user assumes all responsibility and liability for proper and safe handling of the goods. Further, the user indemnifies TI from all claims arising from the handling or use of the goods.

Should this evaluation board/kit not meet the specifications indicated in the User's Guide, the board/kit may be returned within 30 days from the date of delivery for a full refund. THE FOREGOING LIMITED WARRANTY IS THE EXCLUSIVE WARRANTY MADE BY SELLER TO BUYER AND IS IN LIEU OF ALL OTHER WARRANTIES, EXPRESSED, IMPLIED, OR STATUTORY, INCLUDING ANY WARRANTY OF MERCHANTABILITY OR FITNESS FOR ANY PARTICULAR PURPOSE. EXCEPT TO THE EXTENT OF THE INDEMNITY SET FORTH ABOVE, NEITHER PARTY SHALL BE LIABLE TO THE OTHER FOR ANY INDIRECT, SPECIAL, INCIDENTAL, OR CONSEQUENTIAL DAMAGES.

Please read the User's Guide and, specifically, the Warnings and Restrictions notice in the User's Guide prior to handling the product. This notice contains important safety information about temperatures and voltages. For additional information on TI's environmental and/or safety programs, please visit www.ti.com/esh or contact TI.

No license is granted under any patent right or other intellectual property right of TI covering or relating to any machine, process, or combination in which such TI products or services might be or are used. TI currently deals with a variety of customers for products, and therefore our arrangement with the user is not exclusive. TI assumes no liability for applications assistance, customer product design, software performance, or infringement of patents or services described herein.

REGULATORY COMPLIANCE INFORMATION

As noted in the EVM User's Guide and/or EVM itself, this EVM and/or accompanying hardware may or may not be subject to the Federal Communications Commission (FCC) and Industry Canada (IC) rules.

For EVMs **not** subject to the above rules, this evaluation board/kit/module is intended for use for ENGINEERING DEVELOPMENT, DEMONSTRATION OR EVALUATION PURPOSES ONLY and is not considered by TI to be a finished end product fit for general consumer use. It generates, uses, and can radiate radio frequency energy and has not been tested for compliance with the limits of computing devices pursuant to part 15 of FCC or ICES-003 rules, which are designed to provide reasonable protection against radio frequency interference. Operation of the equipment may cause interference with radio communications, in which case the user at his own expense will be required to take whatever measures may be required to correct this interference.

General Statement for EVMs including a radio

User Power/Frequency Use Obligations: This radio is intended for development/professional use only in legally allocated frequency and power limits. Any use of radio frequencies and/or power availability of this EVM and its development application(s) must comply with local laws governing radio spectrum allocation and power limits for this evaluation module. It is the user's sole responsibility to only operate this radio in legally acceptable frequency space and within legally mandated power limitations. Any exceptions to this are strictly prohibited and unauthorized by Texas Instruments unless user has obtained appropriate experimental/development licenses from local regulatory authorities, which is responsibility of user including its acceptable authorization.

For EVMs annotated as FCC – FEDERAL COMMUNICATIONS COMMISSION Part 15 Compliant

Caution

This device complies with part 15 of the FCC Rules. Operation is subject to the following two conditions: (1) This device may not cause harmful interference, and (2) this device must accept any interference received, including interference that may cause undesired operation.

Changes or modifications not expressly approved by the party responsible for compliance could void the user's authority to operate the equipment.

FCC Interference Statement for Class A EVM devices

This equipment has been tested and found to comply with the limits for a Class A digital device, pursuant to part 15 of the FCC Rules. These limits are designed to provide reasonable protection against harmful interference when the equipment is operated in a commercial environment. This equipment generates, uses, and can radiate radio frequency energy and, if not installed and used in accordance with the instruction manual, may cause harmful interference to radio communications. Operation of this equipment in a residential area is likely to cause harmful interference in which case the user will be required to correct the interference at his own expense.

FCC Interference Statement for Class B EVM devices

This equipment has been tested and found to comply with the limits for a Class B digital device, pursuant to part 15 of the FCC Rules. These limits are designed to provide reasonable protection against harmful interference in a residential installation. This equipment generates, uses and can radiate radio frequency energy and, if not installed and used in accordance with the instructions, may cause harmful interference to radio communications. However, there is no guarantee that interference will not occur in a particular installation. If this equipment does cause harmful interference to radio or television reception, which can be determined by turning the equipment off and on, the user is encouraged to try to correct the interference by one or more of the following measures:

- Reorient or relocate the receiving antenna.
- Increase the separation between the equipment and receiver.
- Connect the equipment into an outlet on a circuit different from that to which the receiver is connected.
- Consult the dealer or an experienced radio/TV technician for help.

For EVMs annotated as IC – INDUSTRY CANADA Compliant

This Class A or B digital apparatus complies with Canadian ICES-003.

Changes or modifications not expressly approved by the party responsible for compliance could void the user's authority to operate the equipment.

Concerning EVMs including radio transmitters

This device complies with Industry Canada licence-exempt RSS standard(s). Operation is subject to the following two conditions: (1) this device may not cause interference, and (2) this device must accept any interference, including interference that may cause undesired operation of the device.

Concerning EVMs including detachable antennas

Under Industry Canada regulations, this radio transmitter may only operate using an antenna of a type and maximum (or lesser) gain approved for the transmitter by Industry Canada. To reduce potential radio interference to other users, the antenna type and its gain should be so chosen that the equivalent isotropically radiated power (e.i.r.p.) is not more than that necessary for successful communication.

This radio transmitter has been approved by Industry Canada to operate with the antenna types listed in the user guide with the maximum permissible gain and required antenna impedance for each antenna type indicated. Antenna types not included in this list, having a gain greater than the maximum gain indicated for that type, are strictly prohibited for use with this device.

Cet appareil numérique de la classe A ou B est conforme à la norme NMB-003 du Canada.

Les changements ou les modifications pas expressément approuvés par la partie responsable de la conformité ont pu vider l'autorité de l'utilisateur pour actionner l'équipement.

Concernant les EVMs avec appareils radio

Le présent appareil est conforme aux CNR d'Industrie Canada applicables aux appareils radio exempts de licence. L'exploitation est autorisée aux deux conditions suivantes : (1) l'appareil ne doit pas produire de brouillage, et (2) l'utilisateur de l'appareil doit accepter tout brouillage radioélectrique subi, même si le brouillage est susceptible d'en compromettre le fonctionnement.

Concernant les EVMs avec antennes détachables

Conformément à la réglementation d'Industrie Canada, le présent émetteur radio peut fonctionner avec une antenne d'un type et d'un gain maximal (ou inférieur) approuvé pour l'émetteur par Industrie Canada. Dans le but de réduire les risques de brouillage radioélectrique à l'intention des autres utilisateurs, il faut choisir le type d'antenne et son gain de sorte que la puissance isotrope rayonnée équivalente (p.i.r.e.) ne dépasse pas l'intensité nécessaire à l'établissement d'une communication satisfaisante.

Le présent émetteur radio a été approuvé par Industrie Canada pour fonctionner avec les types d'antenne énumérés dans le manuel d'usage et ayant un gain admissible maximal et l'impédance requise pour chaque type d'antenne. Les types d'antenne non inclus dans cette liste, ou dont le gain est supérieur au gain maximal indiqué, sont strictement interdits pour l'exploitation de l'émetteur.

【Important Notice for Users of this Product in Japan】

This development kit is NOT certified as Confirming to Technical Regulations of Radio Law of Japan

If you use this product in Japan, you are required by Radio Law of Japan to follow the instructions below with respect to this product:

1. Use this product in a shielded room or any other test facility as defined in the notification #173 issued by Ministry of Internal Affairs and Communications on March 28, 2006, based on Sub-section 1.1 of Article 6 of the Ministry's Rule for Enforcement of Radio Law of Japan,
2. Use this product only after you obtained the license of Test Radio Station as provided in Radio Law of Japan with respect to this product, or
3. Use of this product only after you obtained the Technical Regulations Conformity Certification as provided in Radio Law of Japan with respect to this product. Also, please do not transfer this product, unless you give the same notice above to the transferee. Please note that if you could not follow the instructions above, you will be subject to penalties of Radio Law of Japan.

Texas Instruments Japan Limited
(address) 24-1, Nishi-Shinjuku 6 chome, Shinjuku-ku, Tokyo, Japan

<http://www.tij.co.jp>

【ご使用にあたっての注】

本開発キットは技術基準適合証明を受けておりません。

本製品のご使用に際しては、電波法遵守のため、以下のいずれかの措置を取っていただく必要がありますのでご注意ください。

1. 電波法施行規則第6条第1項第1号に基づく平成18年3月28日総務省告示第173号で定められた電波暗室等の試験設備でご使用いただく。
2. 実験局の免許を取得後ご使用いただく。
3. 技術基準適合証明を取得後ご使用いただく。

なお、本製品は、上記の「ご使用にあたっての注意」を譲渡先、移転先に通知しない限り、譲渡、移転できないものとします。

上記を遵守頂けない場合は、電波法の罰則が適用される可能性があることをご留意ください。

日本テキサス・インスツルメンツ株式会社
東京都新宿区西新宿6丁目24番1号
西新宿三井ビル

<http://www.tij.co.jp>

EVALUATION BOARD/KIT/MODULE (EVM) WARNINGS, RESTRICTIONS AND DISCLAIMERS

For Feasibility Evaluation Only, in Laboratory/Development Environments. Unless otherwise indicated, this EVM is not a finished electrical equipment and not intended for consumer use. It is intended solely for use for preliminary feasibility evaluation in laboratory/development environments by technically qualified electronics experts who are familiar with the dangers and application risks associated with handling electrical mechanical components, systems and subsystems. It should not be used as all or part of a finished end product.

Your Sole Responsibility and Risk. You acknowledge, represent and agree that:

1. You have unique knowledge concerning Federal, State and local regulatory requirements (including but not limited to Food and Drug Administration regulations, if applicable) which relate to your products and which relate to your use (and/or that of your employees, affiliates, contractors or designees) of the EVM for evaluation, testing and other purposes.
2. You have full and exclusive responsibility to assure the safety and compliance of your products with all such laws and other applicable regulatory requirements, and also to assure the safety of any activities to be conducted by you and/or your employees, affiliates, contractors or designees, using the EVM. Further, you are responsible to assure that any interfaces (electronic and/or mechanical) between the EVM and any human body are designed with suitable isolation and means to safely limit accessible leakage currents to minimize the risk of electrical shock hazard.
3. You will employ reasonable safeguards to ensure that your use of the EVM will not result in any property damage, injury or death, even if the EVM should fail to perform as described or expected.
4. You will take care of proper disposal and recycling of the EVM's electronic components and packing materials.

Certain Instructions. It is important to operate this EVM within TI's recommended specifications and environmental considerations per the user guidelines. Exceeding the specified EVM ratings (including but not limited to input and output voltage, current, power, and environmental ranges) may cause property damage, personal injury or death. If there are questions concerning these ratings please contact a TI field representative prior to connecting interface electronics including input power and intended loads. Any loads applied outside of the specified output range may result in unintended and/or inaccurate operation and/or possible permanent damage to the EVM and/or interface electronics. Please consult the EVM User's Guide prior to connecting any load to the EVM output. If there is uncertainty as to the load specification, please contact a TI field representative. During normal operation, some circuit components may have case temperatures greater than 60°C as long as the input and output are maintained at a normal ambient operating temperature. These components include but are not limited to linear regulators, switching transistors, pass transistors, and current sense resistors which can be identified using the EVM schematic located in the EVM User's Guide. When placing measurement probes near these devices during normal operation, please be aware that these devices may be very warm to the touch. As with all electronic evaluation tools, only qualified personnel knowledgeable in electronic measurement and diagnostics normally found in development environments should use these EVMs.

Agreement to Defend, Indemnify and Hold Harmless. You agree to defend, indemnify and hold TI, its licensors and their representatives harmless from and against any and all claims, damages, losses, expenses, costs and liabilities (collectively, "Claims") arising out of or in connection with any use of the EVM that is not in accordance with the terms of the agreement. This obligation shall apply whether Claims arise under law of tort or contract or any other legal theory, and even if the EVM fails to perform as described or expected.

Safety-Critical or Life-Critical Applications. If you intend to evaluate the components for possible use in safety critical applications (such as life support) where a failure of the TI product would reasonably be expected to cause severe personal injury or death, such as devices which are classified as FDA Class III or similar classification, then you must specifically notify TI of such intent and enter into a separate Assurance and Indemnity Agreement.

Mailing Address: Texas Instruments, Post Office Box 655303, Dallas, Texas 75265
Copyright © 2012, Texas Instruments Incorporated

IMPORTANT NOTICE

Texas Instruments Incorporated and its subsidiaries (TI) reserve the right to make corrections, enhancements, improvements and other changes to its semiconductor products and services per JESD46, latest issue, and to discontinue any product or service per JESD48, latest issue. Buyers should obtain the latest relevant information before placing orders and should verify that such information is current and complete. All semiconductor products (also referred to herein as "components") are sold subject to TI's terms and conditions of sale supplied at the time of order acknowledgment.

TI warrants performance of its components to the specifications applicable at the time of sale, in accordance with the warranty in TI's terms and conditions of sale of semiconductor products. Testing and other quality control techniques are used to the extent TI deems necessary to support this warranty. Except where mandated by applicable law, testing of all parameters of each component is not necessarily performed.

TI assumes no liability for applications assistance or the design of Buyers' products. Buyers are responsible for their products and applications using TI components. To minimize the risks associated with Buyers' products and applications, Buyers should provide adequate design and operating safeguards.

TI does not warrant or represent that any license, either express or implied, is granted under any patent right, copyright, mask work right, or other intellectual property right relating to any combination, machine, or process in which TI components or services are used. Information published by TI regarding third-party products or services does not constitute a license to use such products or services or a warranty or endorsement thereof. Use of such information may require a license from a third party under the patents or other intellectual property of the third party, or a license from TI under the patents or other intellectual property of TI.

Reproduction of significant portions of TI information in TI data books or data sheets is permissible only if reproduction is without alteration and is accompanied by all associated warranties, conditions, limitations, and notices. TI is not responsible or liable for such altered documentation. Information of third parties may be subject to additional restrictions.

Resale of TI components or services with statements different from or beyond the parameters stated by TI for that component or service voids all express and any implied warranties for the associated TI component or service and is an unfair and deceptive business practice. TI is not responsible or liable for any such statements.

Buyer acknowledges and agrees that it is solely responsible for compliance with all legal, regulatory and safety-related requirements concerning its products, and any use of TI components in its applications, notwithstanding any applications-related information or support that may be provided by TI. Buyer represents and agrees that it has all the necessary expertise to create and implement safeguards which anticipate dangerous consequences of failures, monitor failures and their consequences, lessen the likelihood of failures that might cause harm and take appropriate remedial actions. Buyer will fully indemnify TI and its representatives against any damages arising out of the use of any TI components in safety-critical applications.

In some cases, TI components may be promoted specifically to facilitate safety-related applications. With such components, TI's goal is to help enable customers to design and create their own end-product solutions that meet applicable functional safety standards and requirements. Nonetheless, such components are subject to these terms.

No TI components are authorized for use in FDA Class III (or similar life-critical medical equipment) unless authorized officers of the parties have executed a special agreement specifically governing such use.

Only those TI components which TI has specifically designated as military grade or "enhanced plastic" are designed and intended for use in military/aerospace applications or environments. Buyer acknowledges and agrees that any military or aerospace use of TI components which have **not** been so designated is solely at the Buyer's risk, and that Buyer is solely responsible for compliance with all legal and regulatory requirements in connection with such use.

TI has specifically designated certain components which meet ISO/TS16949 requirements, mainly for automotive use. Components which have not been so designated are neither designed nor intended for automotive use; and TI will not be responsible for any failure of such components to meet such requirements.

Products

Audio	www.ti.com/audio
Amplifiers	amplifier.ti.com
Data Converters	dataconverter.ti.com
DLP® Products	www.dlp.com
DSP	dsp.ti.com
Clocks and Timers	www.ti.com/clocks
Interface	interface.ti.com
Logic	logic.ti.com
Power Mgmt	power.ti.com
Microcontrollers	microcontroller.ti.com
RFID	www.ti-rfid.com
OMAP Applications Processors	www.ti.com/omap
Wireless Connectivity	www.ti.com/wirelessconnectivity

Applications

Automotive and Transportation	www.ti.com/automotive
Communications and Telecom	www.ti.com/communications
Computers and Peripherals	www.ti.com/computers
Consumer Electronics	www.ti.com/consumer-apps
Energy and Lighting	www.ti.com/energy
Industrial	www.ti.com/industrial
Medical	www.ti.com/medical
Security	www.ti.com/security
Space, Avionics and Defense	www.ti.com/space-avionics-defense
Video and Imaging	www.ti.com/video

TI E2E Community

e2e.ti.com