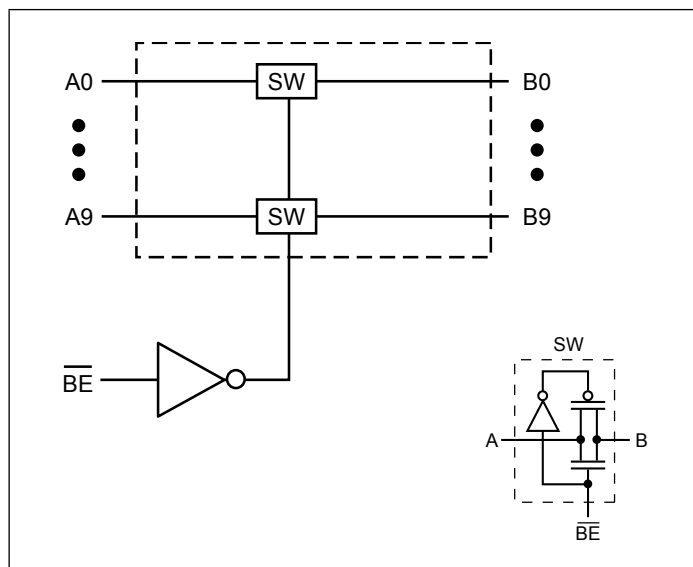
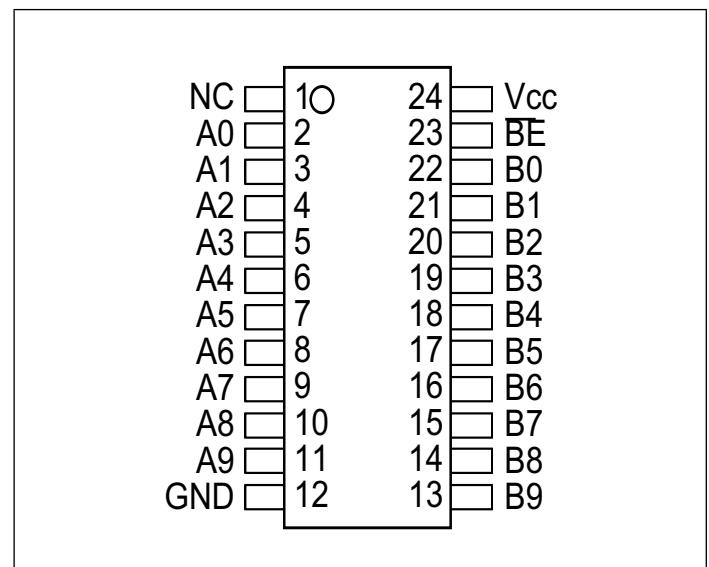

**Features**

- Near-Zero propagation delay
- 5-ohm switches connect inputs to outputs
- Fast Switching Speed: 4.5ns (max.)
- Ultra Low Quiescent Power (0.1µA typical)
  - Ideally suited for notebook applications
- Packaging (Pb-free & Green):
  - 24-pin 150-mil wide plastic QSOP (Q)

**Description**

Pericom Semiconductor's PI3B3861 is a 10-bit, 3.3 volt, 2-port bus switch designed with a low On-Resistance (5-ohm) allowing inputs to be connected directly to outputs. The bus switch creates no additional propagational delay or additional ground bounce noise. The switches are turned ON by the Bus Enable ( $\overline{BE}$ ) input signal.

**Block Diagram**

**Pin Configuration**

**Truth Table<sup>(1)</sup>**

Function	$\overline{BE}$	A0-9
Disconnect	H	Hi-Z
Connect	L	B0-9

Note: H = High Voltage Level  
 L = Low Voltage Level  
 Hi-Z = High Impedance

**Pin Description**

Pin Name	Description
$\overline{BE}$	Bus Enable Input (Active LOW)
A0-9	Bus A
B0-9	Bus B
GND	Ground
V <sub>CC</sub>	Power

## Absolute Maximum Ratings

Parameter	Min.	Max.	Units
Storage Temperature	-65	150	°C
Ambient Temperature with Power Applied	-40	85	°C
Supply Voltage to Ground Potential	-0.5	4.6	V
DC Input Voltage	-0.5	4.6	V
DC Output Current	-	120	mA
Power Dissipation	-	0.5	W

Stress beyond those listed under “Absolute Maximum Ratings” may cause permanent damage to the device.

## DC Electrical Characteristics (Over the Operating Range, $T_A = -40^{\circ}\text{C}$ to $+85^{\circ}\text{C}$ , $V_{CC} = 3.3\text{V} \pm 10\%$ )

Parameters	Description	Test Conditions <sup>(1)</sup>	Min	Typ <sup>(2)</sup>	Max	Units
$V_{IH}$	Input HIGH Voltage	Guaranteed Logic HIGH Level	2.0			V
$V_{IL}$	Input LOW Voltage	Guaranteed Logic LOW Level	-0.5		0.8	V
$I_{IH}$	Input HIGH Current	$V_{CC} = \text{Max.}, V_{IN} = V_{CC}$			$\pm 1$	$\mu\text{A}$
$I_{IL}$	Input LOW Current	$V_{CC} = \text{Max.}, V_{IN} = \text{GND}$			$\pm 1$	$\mu\text{A}$
$I_{OZH}$	High Impedance Output Current	$0 \leq A, B \leq V_{CC}$			$\pm 1$	$\mu\text{A}$
$V_{IK}$	Clamp Diode Voltage	$V_{CC} = \text{Min.}, I_{IN} = -18 \text{ mA}$			-1.2	V
$R_{ON}$	Switch On Resistance <sup>(3)</sup>	$V_{CC} = \text{Min.}, V_{IN} = 0.0\text{V}, I_{ON} = 48\text{mA}$ or $64\text{mA}$		5	8	$\Omega$
		$V_{CC} = \text{Min.}, V_{IN} = 2.4\text{V}, I_{ON} = 15\text{mA}$		10	17	

Notes:

- For Max. or Min. conditions, use appropriate value specified under Electrical Characteristics for the applicable device type.
- Typical values are at  $V_{CC} = 3.3\text{V}$ ,  $T_A = 25^{\circ}\text{C}$  ambient and maximum loading.
- Measured by the voltage drop between A and B pin at indicated current through the switch. ON resistance is determined by the lower of the voltages on the two (A,B) pins.

## Capacitance ( $T_A = 25^{\circ}\text{C}$ , $f = 1 \text{ MHz}$ )

Parameters <sup>(1)</sup>	Description	Test Conditions	Typ	Units
$C_{IN}$	Input Capacitance	$V_{IN} = 0\text{V}$	3.0	pF
$C_{OFF}$	A/B Capacitance, Switch Off	$V_{IN} = 0\text{V}$	8.0	pF
$C_{ON}$	A/B Capacitance, Switch On	$V_{IN} = 0\text{V}$	16.0	pF

Notes:

- This parameter is determined by device characterization but is not production tested.

## Power Supply Characteristics

Parameters	Description	Test Conditions <sup>(1)</sup>		Min	Typ <sup>(2)</sup>	Max	Units
I <sub>CC</sub>	Quiescent Power Supply Current	V <sub>CC</sub> = Max.	V <sub>IN</sub> = GND or V <sub>CC</sub>		0.1	3.0	μA
ΔI <sub>CC</sub>	Supply Current per Input @ TTL HIGH	V <sub>CC</sub> = Max.	V <sub>IN</sub> = 3.0V <sup>(3)</sup>			750	μA

### Notes:

1. For Max. or Min. conditions, use appropriate value specified under Electrical Characteristics for the applicable device.
2. Typical values are at V<sub>CC</sub> = 3.3V, +25°C ambient.
3. Per TTL driven input (control input only); A and B pins do not contribute to I<sub>CC</sub>.

## Switching Characteristics over Operating Range

Parameters	Description	Test Conditions <sup>(1)</sup>	Com.		Units
			Min	Max	
t <sub>PLH</sub> t <sub>PHL</sub>	Propagation Delay <sup>(2,3)</sup> Ax to Bx, Bx to Ax	CL = 50 pF RL = 500Ω		0.25	ns
t <sub>PZH</sub> t <sub>PZL</sub>	Bus Enable Time $\overline{\text{BE}}$ to Ax or Bx		1	4.5	
t <sub>PHZ</sub> t <sub>PLZ</sub>	Bus Disable Time $\overline{\text{BE}}$ to Ax or Bx		1	4.5	

### Notes:

1. See test circuit and wave forms.
2. This parameter is guaranteed but not tested on Propagation Delays.
3. The bus switch contributes no propagational delay other than the RC delay of the On-Resistance of the switch and the load capacitance. The time constant for the switch alone is of the order of 0.25 ns for 50 pF load. Since this time constant is much smaller than the rise/fall times of typical driving signals, it adds very little propagational delay to the system. Propagational delay of the bus switch when used in a system is determined by the driving circuit on the driving side of the switch and its interaction with the load on the driven side.

## Applications Information

### Logic Inputs

The logic control inputs can be driven up to +3.6V regardless of the supply voltage. For example, given a + 3.3V supply, IN may be driven low to 0V and high to 3.6V. Driving IN Rail-to-Rail® minimizes power consumption.

### Power-Supply Sequencing and Hot-Plug Information

Proper power-supply sequencing is recommended for all CMOS devices. Always apply V<sub>CC</sub> and GND before applying signals to input/output or control pins.

*Rail-to-Rail is a registered trademark of Nippon Motorola, Ltd.*

**Test Circuits**

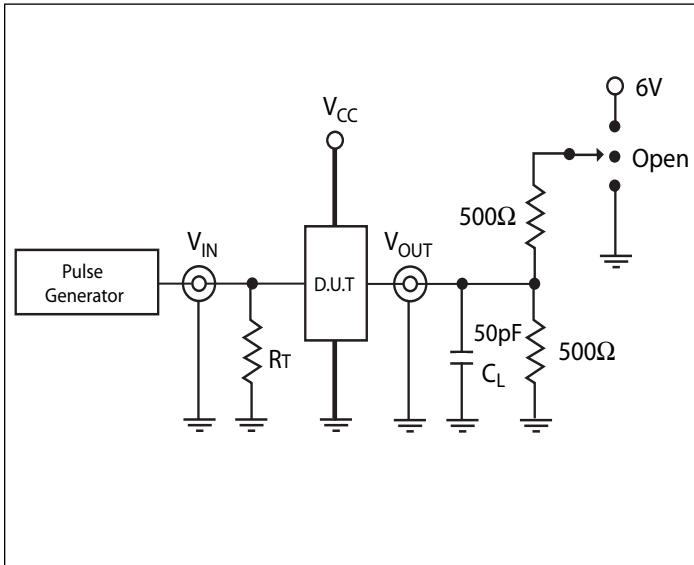

**Switch Position**

Test	Switch
Disable LOW	6V
Enable LOW	6V
Disable HIGH	GND
Enable HIGH	GND
t <sub>PD</sub>	Open

Definitions:

CL = Load capacitance (includes jig and probe capacitance)

RT = Termination resistance (should be equal to Z<sub>OUT</sub> of the pulse generator)

**Enable and Disable Timing**

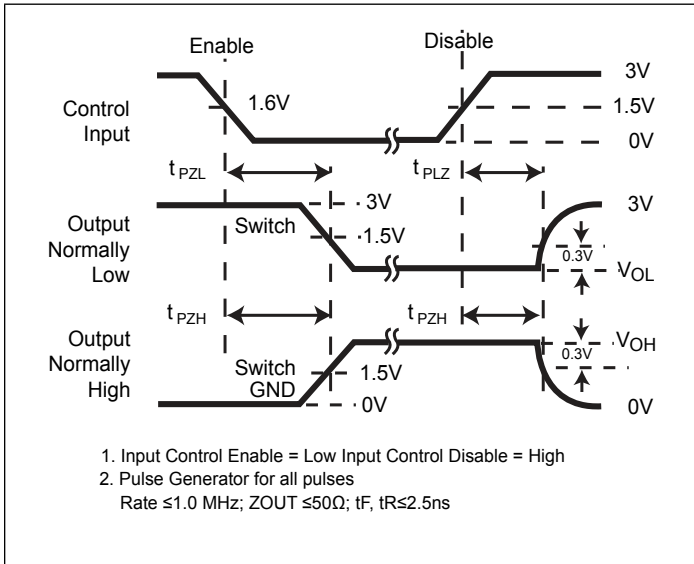

**Propagation Delay**

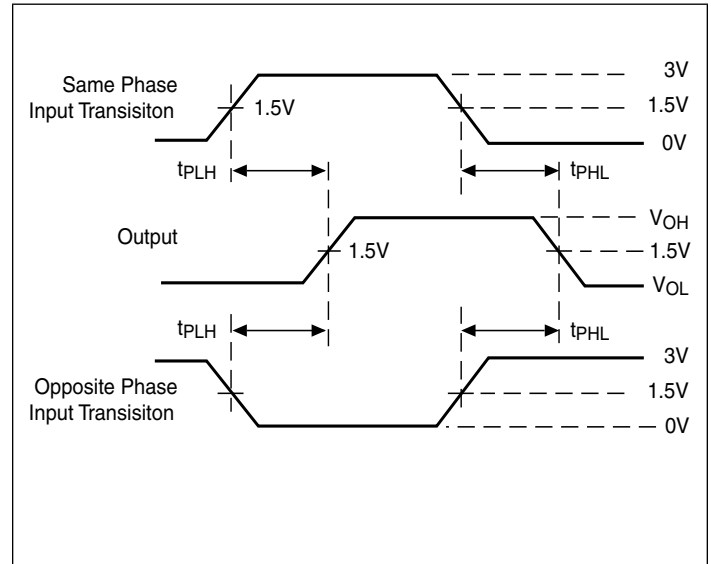

**Packaging Mechanical: 24-pin QSOP (Q)**

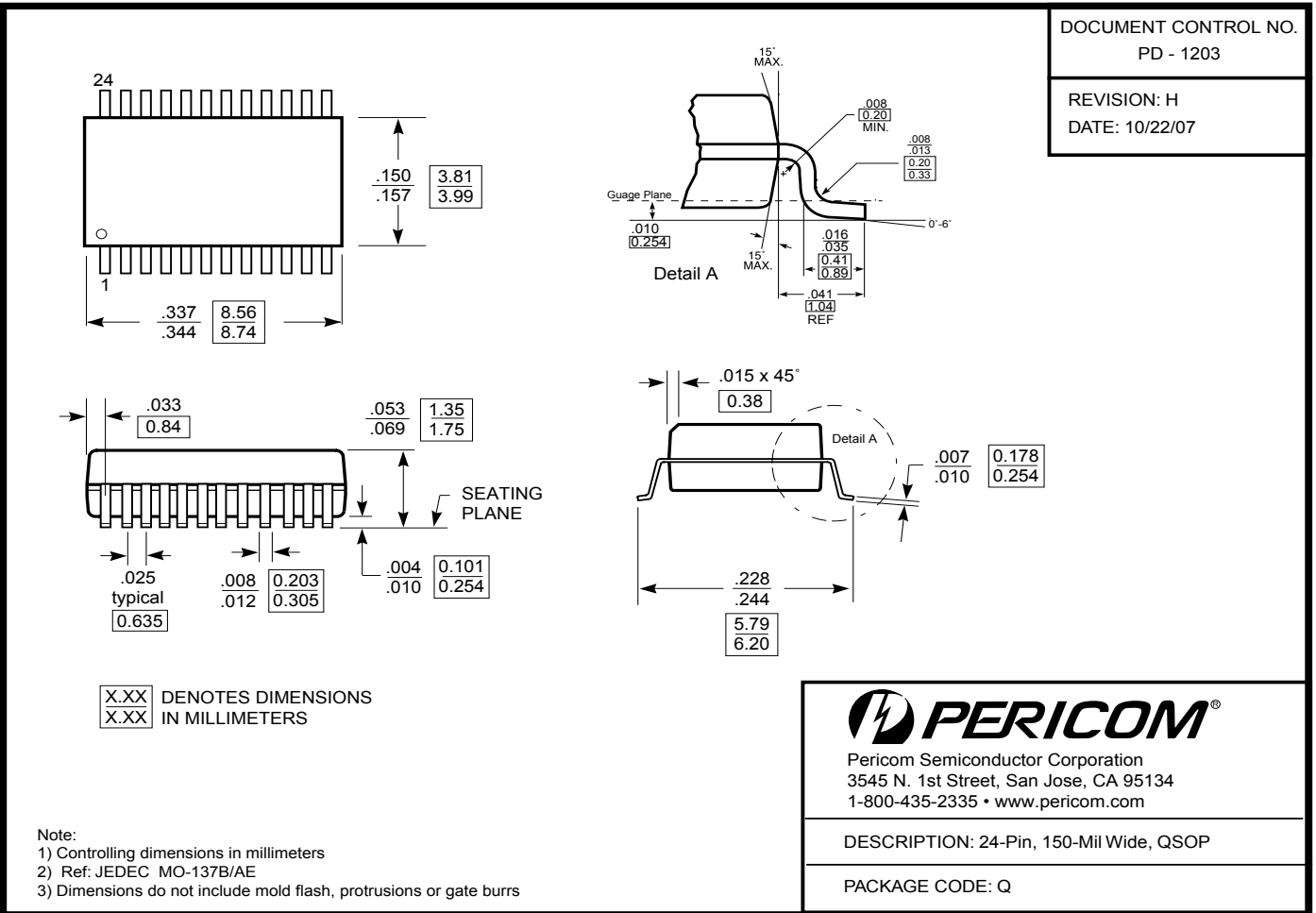

07-0475

**Ordering Information**

Ordering Code	Package Code	Package Type
PI3B3861QE	Q	Pb-free & Green, 24-pin QSOP

1. Thermal characteristics can be found on the company web site at [www.pericom.com/packaging/](http://www.pericom.com/packaging/)