

# 74ABT16244A

16-bit buffer/line driver; 3-state

Rev. 8 — 3 November 2011

Product data sheet

## 1. General description

The 74ABT16244A high-performance Bipolar CMOS (BiCMOS) device combines low static and dynamic power dissipation with high speed and high output drive.

The 74ABT16244A is a 16-bit buffer that is ideal for driving bus lines. The device features four output enable inputs ( $\overline{1OE}$ ,  $\overline{2OE}$ ,  $\overline{3OE}$ ,  $\overline{4OE}$ ), each controlling four of the 3-state outputs.

## 2. Features and benefits

- 16-bit bus interface
- Multiple  $V_{CC}$  and GND pins minimize switching noise
- Power-up 3-state
- 3-state buffers
- Output capability: +64 mA and -32 mA
- Live insertion and extraction permitted
- Latch-up performance: JESD 78 Class II
- ESD protection:
  - ◆ HBM JESD-A114E exceeds 2000 V
  - ◆ CDM JESD 22-C101-C exceeds 1000 V

## 3. Ordering information

Table 1. Ordering information

Type number	Package			
	Temperature range	Name	Description	Version
74ABT16244ADGG	-40 °C to +85 °C	TSSOP48	plastic thin shrink small outline package; 48 leads; body width 6.1 mm	SOT362-1
74ABT16244ADL	-40 °C to +85 °C	SSOP48	plastic shrink small outline package; 48 leads; body width 7.5 mm	SOT370-1



## 4. Functional diagram

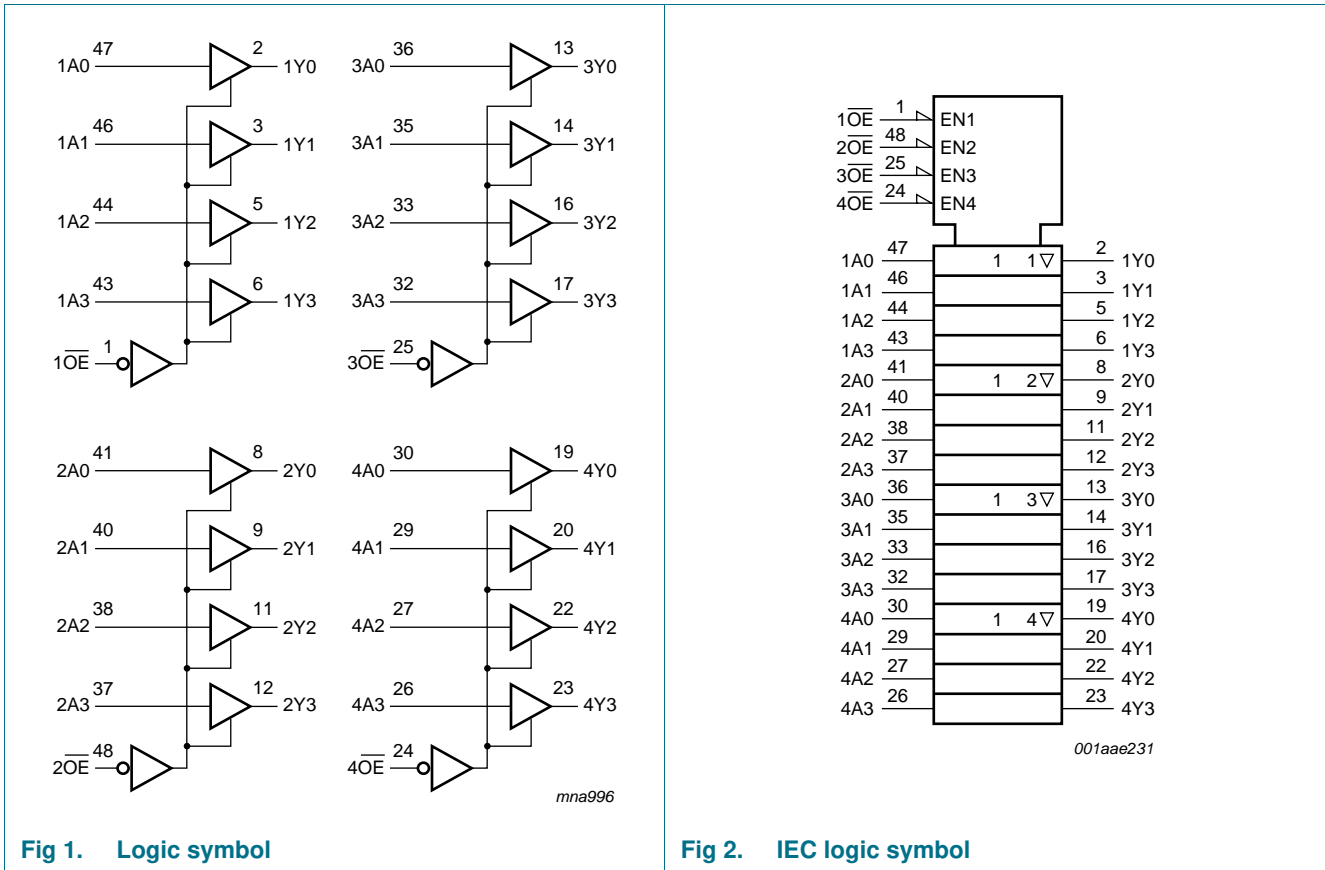

## 5. Pinning information

### 5.1 Pinning

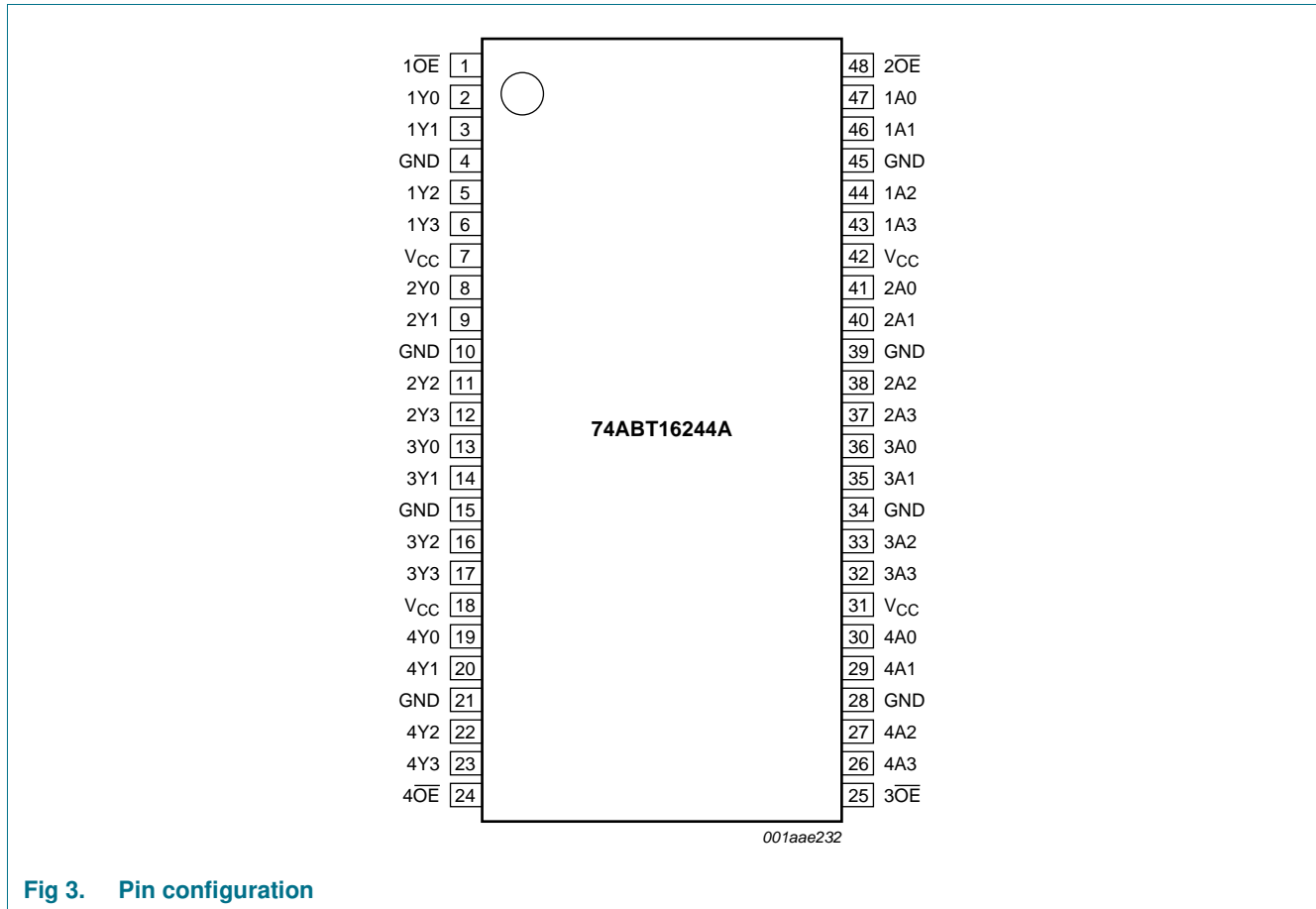

Fig 3. Pin configuration

### 5.2 Pin description

Table 2. Pin description

Symbol	Pin	Description
1OE	1	1 output enable (LOW active)
1Y[0:3]	2, 3, 5, 6	1 data output 0 to output 3
GND	4	ground (0 V)
V <sub>CC</sub>	7	supply voltage
2Y[0:3]	8, 9, 11, 12	2 data output 0 to output 3
GND	10	ground (0 V)
3Y[0:3]	13, 14, 16, 17	3 data output 0 to output 3
GND	15	ground (0 V)
V <sub>CC</sub>	18	supply voltage
4Y[0:3]	19, 20, 22, 23	4 data output 0 to output 3
GND	21	ground (0 V)

Table 2. Pin description ...continued

Symbol	Pin	Description
$\overline{4OE}$	24	4 output enable (LOW active)
$\overline{3OE}$	25	3 output enable (LOW active)
GND	28	ground (0 V)
4A[0:3]	30, 29, 27, 26	4 data input 0 to input 3
V <sub>CC</sub>	31	supply voltage
GND	34	ground (0 V)
3A[0:3]	36, 35, 33, 32	3 data input 0 to input 3
GND	39	ground (0 V)
2A[0:3]	41, 40, 38, 37	2 data input 0 to input 3
V <sub>CC</sub>	42	supply voltage
GND	45	ground (0 V)
1A[0:3]	47, 46, 44, 43	1 data input 0 to input 3
$\overline{2OE}$	48	2 output enable (LOW active)

## 6. Functional description

Table 3. Function table<sup>[1]</sup>

Control	Input	Output
$\overline{\text{nOE}}$	nAn	nYn
L	L	L
	H	H
H	X	Z

- [1] H = HIGH voltage level;  
L = LOW voltage level;  
X = don't care;  
Z = high-impedance OFF-state.

## 7. Limiting values

Table 4. Limiting values

In accordance with the Absolute Maximum Rating System (IEC 60134).

Symbol	Parameter	Conditions	Min	Max	Unit
$V_{CC}$	supply voltage		-0.5	+7.0	V
$V_I$	input voltage		<sup>[1]</sup> -1.2	+7.0	V
$V_O$	output voltage	output in OFF-state or HIGH-state	<sup>[1]</sup> -0.5	+5.5	V
$I_{IK}$	input clamping current	$V_I < 0$ V	-18	-	mA
$I_{OK}$	output clamping current	$V_O < 0$ V	-50	-	mA
$I_O$	output current	output in LOW-state	-	128	mA
		output in HIGH-state	-	-64	mA
$T_j$	junction temperature		<sup>[2]</sup> -	150	°C
$T_{stg}$	storage temperature		-65	+150	°C

- [1] The input and output voltage ratings may be exceeded if the input and output current ratings are observed.  
[2] The performance capability of a high-performance integrated circuit in conjunction with its thermal environment can create junction temperatures which are detrimental to reliability.

## 8. Recommended operating conditions

Table 5. Operating conditions

Voltages are referenced to GND (ground = 0 V).

Symbol	Parameter	Conditions	Min	Typ	Max	Unit
$V_{CC}$	supply voltage		4.5	-	5.5	V
$V_I$	input voltage		0	-	$V_{CC}$	V
$V_{IH}$	HIGH-level input voltage		2.0	-	-	V
$V_{IL}$	LOW-level Input voltage		-	-	0.8	V
$I_{OH}$	HIGH-level output current		-32	-	-	mA
$I_{OL}$	LOW-level output current		-	-	64	mA
$\Delta t/\Delta V$	input transition rise and fall rate		-	-	10	ns/V
$T_{amb}$	ambient temperature	in free air	-40	-	+85	°C

## 9. Static characteristics

Table 6. Static characteristics

Symbol	Parameter	Conditions	25 °C			-40 °C to +85 °C		Unit	
			Min	Typ	Max	Min	Max		
$V_{IK}$	input clamping voltage	$V_{CC} = 4.5 \text{ V}$ ; $I_{IK} = -18 \text{ mA}$	-	-0.9	-1.2	-	-1.2	V	
$V_{OH}$	HIGH-level output voltage	$V_I = V_{IL}$ or $V_{IH}$							
		$V_{CC} = 4.5 \text{ V}$ ; $I_{OH} = -3 \text{ mA}$	2.5	2.9	-	2.5	-	V	
		$V_{CC} = 5.0 \text{ V}$ ; $I_{OH} = -3 \text{ mA}$	3.0	3.4	-	3.0	-	V	
		$V_{CC} = 4.5 \text{ V}$ ; $I_{OH} = -32 \text{ mA}$	2.0	2.4	-	2.0	-	V	
$V_{OL}$	LOW-level output voltage	$V_{CC} = 4.5 \text{ V}$ ; $I_{OL} = 64 \text{ mA}$ ; $V_I = V_{IL}$ or $V_{IH}$	-	0.42	0.55	-	0.55	V	
$I_I$	input leakage current	$V_{CC} = 5.5 \text{ V}$ ; $V_I = V_{CC}$ or GND	-	$\pm 0.01$	$\pm 1.0$	-	$\pm 1.0$	$\mu\text{A}$	
$I_{OFF}$	power-off leakage current	$V_{CC} = 0 \text{ V}$ ; $V_I$ or $V_O \leq 4.5 \text{ V}$	-	$\pm 5.0$	$\pm 100$	-	$\pm 100$	$\mu\text{A}$	
$I_{O(pu/pd)}$	power-up/power-down output current	$V_{CC} = 2.0 \text{ V}$ ; $V_O = 0.5 \text{ V}$ ; $V_I = \text{GND}$ or $V_{CC}$ ; $n\overline{OE} = \text{HIGH}$	[1]	$\pm 5.0$	$\pm 50$	-	$\pm 50$	$\mu\text{A}$	
$I_{OZ}$	OFF-state output current	$V_{CC} = 5.5 \text{ V}$ ; $V_I = V_{IL}$ or $V_{IH}$							
		output HIGH-state at $V_O = 5.5 \text{ V}$	-	0.1	10	-	10	$\mu\text{A}$	
		output LOW-state at $V_O = 0 \text{ V}$	-	-0.1	-10	-	-10	$\mu\text{A}$	
$I_{LO}$	output leakage current	HIGH-state; $V_O = 5.5 \text{ V}$ ; $V_{CC} = 5.5 \text{ V}$ ; $V_I = \text{GND}$ or $V_{CC}$	-	5.0	50	-	50	$\mu\text{A}$	
$I_O$	output current	$V_{CC} = 5.5 \text{ V}$ ; $V_O = 2.5 \text{ V}$	[2]	-50	-100	-180	-50	-180	mA
$I_{CC}$	supply current	$V_{CC} = 5.5 \text{ V}$ ; $V_I = \text{GND}$ or $V_{CC}$							
		outputs HIGH-state	-	0.45	1.0	-	1.0	mA	
		outputs LOW-state	-	10	19	-	19	mA	
		outputs 3-state	-	0.45	1.0	-	1.0	mA	
$\Delta I_{CC}$	additional supply current	per input pin; $V_{CC} = 5.5 \text{ V}$ ; one input at 3.4 V and other inputs at $V_{CC}$ or GND	[3][4]	-	100	250	-	250	$\mu\text{A}$
$C_I$	input capacitance	$V_I = 0 \text{ V}$ or $V_{CC}$	-	4	-	-	-	pF	
$C_{I/O}$	input/output capacitance	outputs disabled; $V_O = 0 \text{ V}$ or $V_{CC}$	-	7	-	-	-	pF	

[1] This parameter is valid for any  $V_{CC}$  between 0 V and 2.1 V, with a transition time of up to 10 ms. From  $V_{CC} = 2.1 \text{ V}$  to  $V_{CC} = 5 \text{ V} \pm 10 \%$ , a transition time of up to 100  $\mu\text{s}$  is permitted.

[2] Not more than one output should be tested at a time, and the duration of the test should not exceed one second.

[3] This is the increase in supply current for each input at 3.4 V.

[4] This data sheet limit may vary among suppliers.

## 10. Dynamic characteristics

**Table 7. Dynamic characteristics**  
*GND = 0 V. For test circuit, see [Figure 6](#).*

Symbol	Parameter	Conditions	25 °C; V <sub>CC</sub> = 5.0 V			–40 °C to +85 °C; V <sub>CC</sub> = 5.0 V ± 0.5 V		Unit
			Min	Typ	Max	Min	Max	
t <sub>PLH</sub>	LOW to HIGH propagation delay	nAn to nYn; see <a href="#">Figure 4</a>	1.1	1.7	2.6	1.1	2.8	ns
t <sub>PHL</sub>	HIGH to LOW propagation delay	nAn to nYn; see <a href="#">Figure 4</a>	1.3	2.1	2.9	1.3	3.4	ns
t <sub>PZH</sub>	OFF-state to HIGH propagation delay	n $\overline{\text{OE}}$ to nYn; see <a href="#">Figure 5</a>	1.6	2.7	3.7	1.6	4.5	ns
t <sub>PZL</sub>	OFF-state to LOW propagation delay	n $\overline{\text{OE}}$ to nYn; see <a href="#">Figure 5</a>	2.3	3.5	4.0	2.3	4.8	ns
t <sub>PHZ</sub>	HIGH to OFF-state propagation delay	n $\overline{\text{OE}}$ to nYn; see <a href="#">Figure 5</a>	1.5	3.0	4.0	1.5	4.6	ns
t <sub>PLZ</sub>	LOW to OFF-state propagation delay	n $\overline{\text{OE}}$ to nYn; see <a href="#">Figure 5</a>	1.6	2.4	3.2	1.6	4.1	ns

11. Waveforms

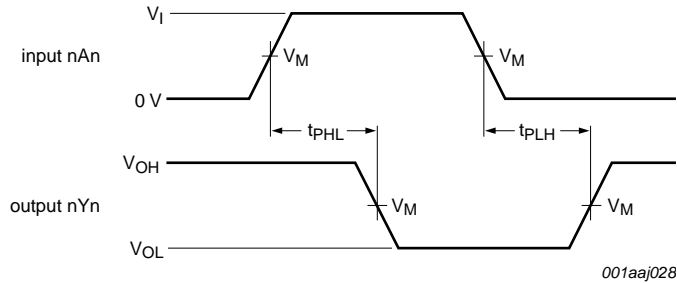

$V_M = 1.5\text{ V}$   
 $V_{OL}$  and  $V_{OH}$  are typical voltage output levels that occur with the output load.

**Fig 4. Input (nAn) to output (nYn) propagation delay**

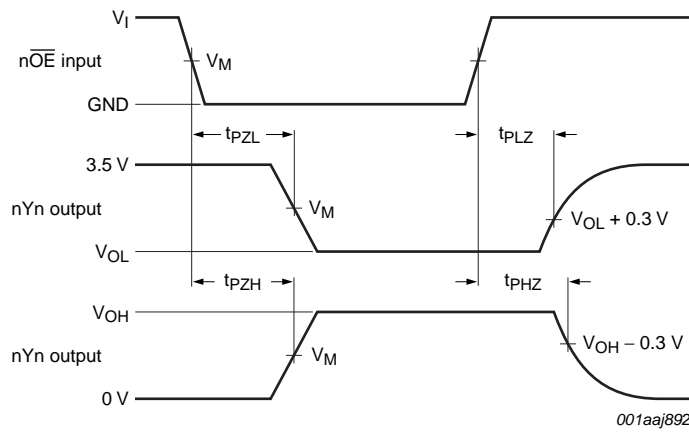

$V_M = 1.5\text{ V}$   
 $V_{OL}$  and  $V_{OH}$  are typical voltage output levels that occur with the output load.

**Fig 5. 3-state output enable and disable times**



12. Test information

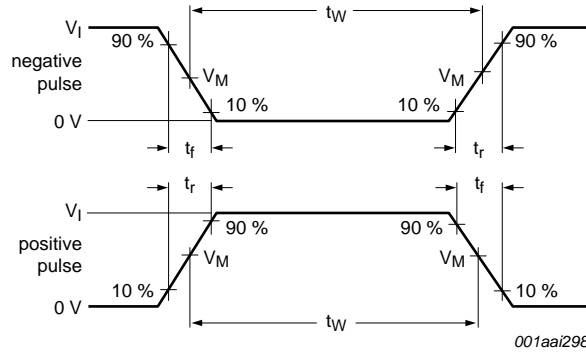

$V_M = 1.5\text{ V}$   
 a. Input pulse definition

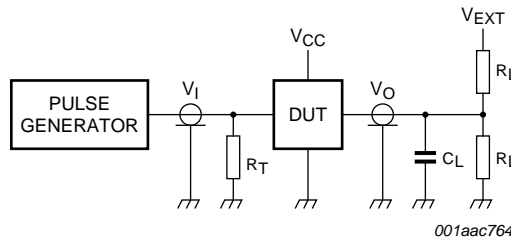

Test data is given in [Table 8](#).

Definitions test circuit:

$R_L$  = Load resistance.

$C_L$  = Load capacitance including jig and probe capacitance.

$R_T$  = Termination resistance should be equal to output impedance  $Z_o$  of the pulse generator.

b. Test circuit for 3-state outputs

Fig 6. Load circuitry for switching times

Table 8. Test data

Input				Load		$V_{EXT}$		
$V_I$	$f_i$	$t_w$	$t_r, t_f$	$C_L$	$R_L$	$t_{PHZ}, t_{PZH}$	$t_{PLZ}, t_{PZL}$	$t_{PLH}, t_{PHL}$
3.0 V	1 MHz	500 ns	2.5 ns	50 pF	500 $\Omega$	open	7.0 V	open

13. Package outline

TSSOP48: plastic thin shrink small outline package; 48 leads; body width 6.1 mm

SOT362-1

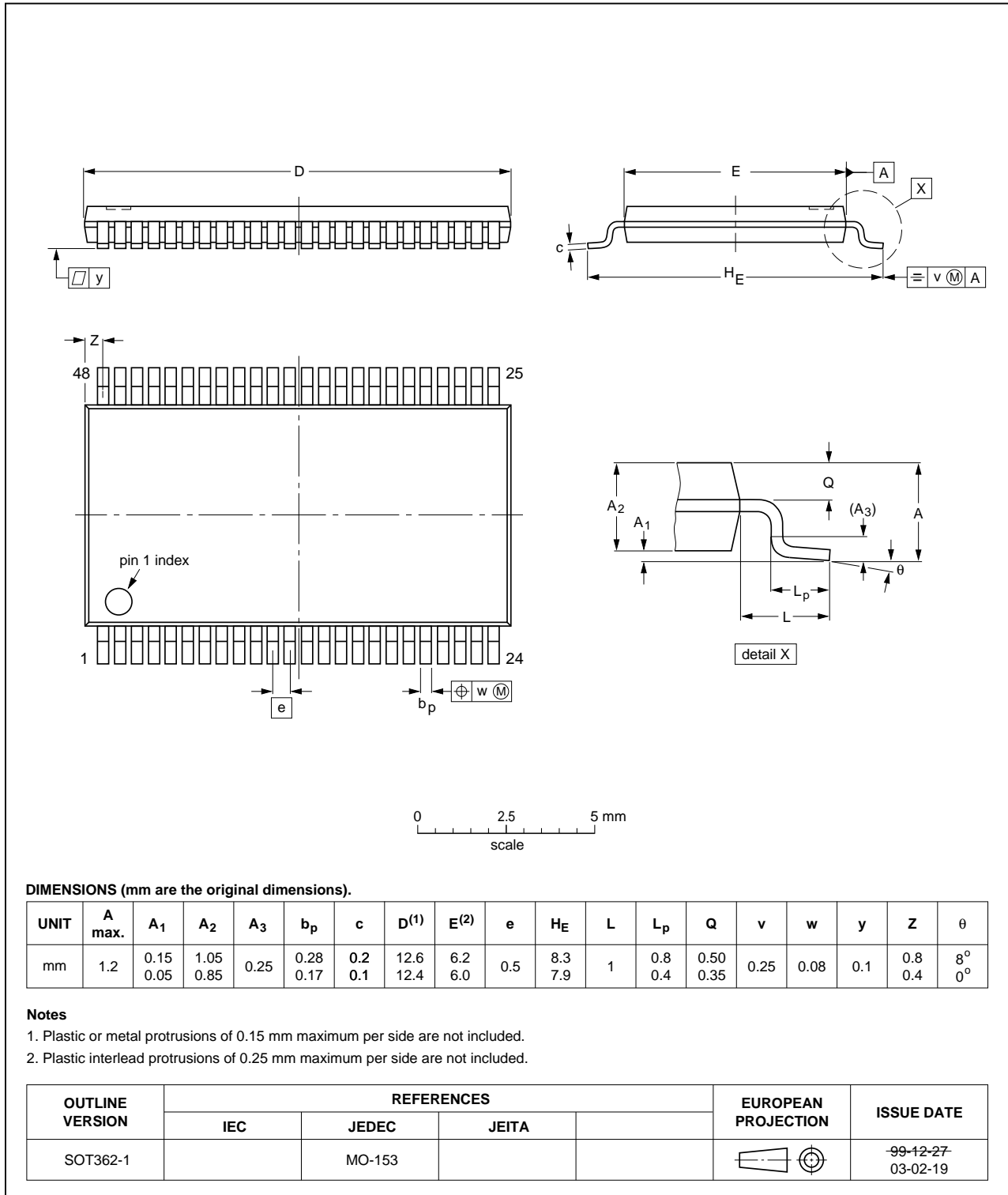

Fig 7. Package outline SOT362-1 (TSSOP48)

SSOP48: plastic shrink small outline package; 48 leads; body width 7.5 mm

SOT370-1

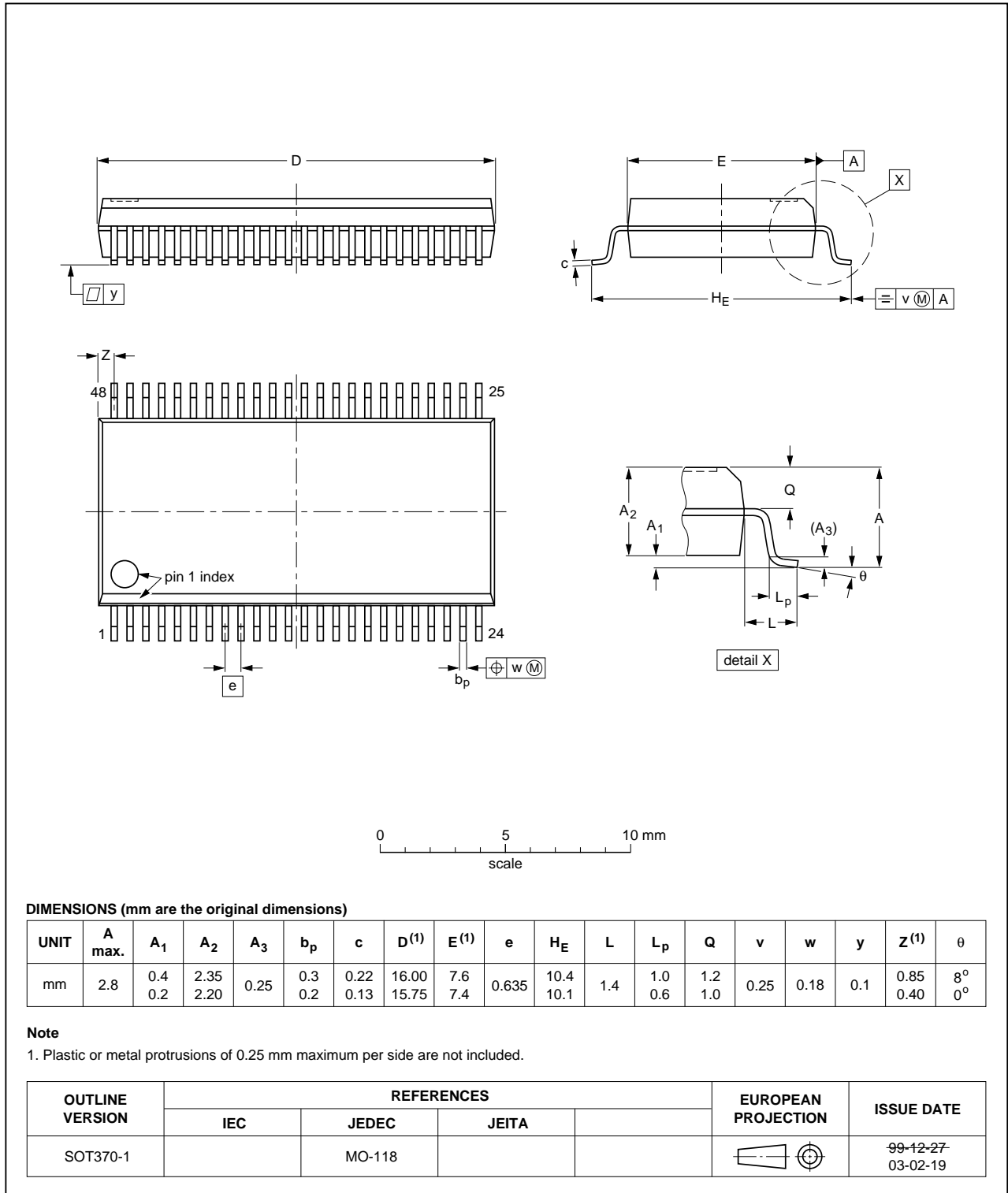

Fig 8. Package outline SOT370-1 (SSOP48)

## 14. Revision history

**Table 9. Revision history**

Document ID	Release date	Data sheet status	Change notice	Supersedes
74ABT16244A v.8	20111103	Product data sheet	-	74ABT16244A v.7
Modifications:	• Legal pages updated			
74ABT16244A v.7	20100525	Product data sheet	-	74ABT16244A v.6
74ABT16244A v.6	20090323	Product data sheet	-	74ABT16244A v.5
74ABT16244A v.5	20060210	Product data sheet	-	74ABT_H16244A v.4
74ABT_H16244A v.4	19981007	Product specification	-	74ABT_H16244A v.3
74ABT_H16244A v.3	19980225	Product specification	-	74ABT_H16244A v.2

## 15. Legal information

### 15.1 Data sheet status

Document status <sup>[1][2]</sup>	Product status <sup>[3]</sup>	Definition
Objective [short] data sheet	Development	This document contains data from the objective specification for product development.
Preliminary [short] data sheet	Qualification	This document contains data from the preliminary specification.
Product [short] data sheet	Production	This document contains the product specification.

[1] Please consult the most recently issued document before initiating or completing a design.

[2] The term 'short data sheet' is explained in section "Definitions".

[3] The product status of device(s) described in this document may have changed since this document was published and may differ in case of multiple devices. The latest product status information is available on the Internet at URL <http://www.nxp.com>.

### 15.2 Definitions

**Draft** — The document is a draft version only. The content is still under internal review and subject to formal approval, which may result in modifications or additions. NXP Semiconductors does not give any representations or warranties as to the accuracy or completeness of information included herein and shall have no liability for the consequences of use of such information.

**Short data sheet** — A short data sheet is an extract from a full data sheet with the same product type number(s) and title. A short data sheet is intended for quick reference only and should not be relied upon to contain detailed and full information. For detailed and full information see the relevant full data sheet, which is available on request via the local NXP Semiconductors sales office. In case of any inconsistency or conflict with the short data sheet, the full data sheet shall prevail.

**Product specification** — The information and data provided in a Product data sheet shall define the specification of the product as agreed between NXP Semiconductors and its customer, unless NXP Semiconductors and customer have explicitly agreed otherwise in writing. In no event however, shall an agreement be valid in which the NXP Semiconductors product is deemed to offer functions and qualities beyond those described in the Product data sheet.

### 15.3 Disclaimers

**Limited warranty and liability** — Information in this document is believed to be accurate and reliable. However, NXP Semiconductors does not give any representations or warranties, expressed or implied, as to the accuracy or completeness of such information and shall have no liability for the consequences of use of such information.

In no event shall NXP Semiconductors be liable for any indirect, incidental, punitive, special or consequential damages (including - without limitation - lost profits, lost savings, business interruption, costs related to the removal or replacement of any products or rework charges) whether or not such damages are based on tort (including negligence), warranty, breach of contract or any other legal theory.

Notwithstanding any damages that customer might incur for any reason whatsoever, NXP Semiconductors' aggregate and cumulative liability towards customer for the products described herein shall be limited in accordance with the *Terms and conditions of commercial sale* of NXP Semiconductors.

**Right to make changes** — NXP Semiconductors reserves the right to make changes to information published in this document, including without limitation specifications and product descriptions, at any time and without notice. This document supersedes and replaces all information supplied prior to the publication hereof.

**Suitability for use** — NXP Semiconductors products are not designed, authorized or warranted to be suitable for use in life support, life-critical or safety-critical systems or equipment, nor in applications where failure or

malfunction of an NXP Semiconductors product can reasonably be expected to result in personal injury, death or severe property or environmental damage. NXP Semiconductors accepts no liability for inclusion and/or use of NXP Semiconductors products in such equipment or applications and therefore such inclusion and/or use is at the customer's own risk.

**Applications** — Applications that are described herein for any of these products are for illustrative purposes only. NXP Semiconductors makes no representation or warranty that such applications will be suitable for the specified use without further testing or modification.

Customers are responsible for the design and operation of their applications and products using NXP Semiconductors products, and NXP Semiconductors accepts no liability for any assistance with applications or customer product design. It is customer's sole responsibility to determine whether the NXP Semiconductors product is suitable and fit for the customer's applications and products planned, as well as for the planned application and use of customer's third party customer(s). Customers should provide appropriate design and operating safeguards to minimize the risks associated with their applications and products.

NXP Semiconductors does not accept any liability related to any default, damage, costs or problem which is based on any weakness or default in the customer's applications or products, or the application or use by customer's third party customer(s). Customer is responsible for doing all necessary testing for the customer's applications and products using NXP Semiconductors products in order to avoid a default of the applications and the products or of the application or use by customer's third party customer(s). NXP does not accept any liability in this respect.

**Limiting values** — Stress above one or more limiting values (as defined in the Absolute Maximum Ratings System of IEC 60134) will cause permanent damage to the device. Limiting values are stress ratings only and (proper) operation of the device at these or any other conditions above those given in the Recommended operating conditions section (if present) or the Characteristics sections of this document is not warranted. Constant or repeated exposure to limiting values will permanently and irreversibly affect the quality and reliability of the device.

**Terms and conditions of commercial sale** — NXP Semiconductors products are sold subject to the general terms and conditions of commercial sale, as published at <http://www.nxp.com/profile/terms>, unless otherwise agreed in a valid written individual agreement. In case an individual agreement is concluded only the terms and conditions of the respective agreement shall apply. NXP Semiconductors hereby expressly objects to applying the customer's general terms and conditions with regard to the purchase of NXP Semiconductors products by customer.

**No offer to sell or license** — Nothing in this document may be interpreted or construed as an offer to sell products that is open for acceptance or the grant, conveyance or implication of any license under any copyrights, patents or other industrial or intellectual property rights.

**Export control** — This document as well as the item(s) described herein may be subject to export control regulations. Export might require a prior authorization from competent authorities.

**Non-automotive qualified products** — Unless this data sheet expressly states that this specific NXP Semiconductors product is automotive qualified, the product is not suitable for automotive use. It is neither qualified nor tested in accordance with automotive testing or application requirements. NXP Semiconductors accepts no liability for inclusion and/or use of non-automotive qualified products in automotive equipment or applications.

In the event that customer uses the product for design-in and use in automotive applications to automotive specifications and standards, customer (a) shall use the product without NXP Semiconductors' warranty of the product for such automotive applications, use and specifications, and (b) whenever customer uses the product for automotive applications beyond

NXP Semiconductors' specifications such use shall be solely at customer's own risk, and (c) customer fully indemnifies NXP Semiconductors for any liability, damages or failed product claims resulting from customer design and use of the product for automotive applications beyond NXP Semiconductors' standard warranty and NXP Semiconductors' product specifications.

## 15.4 Trademarks

Notice: All referenced brands, product names, service names and trademarks are the property of their respective owners.

## 16. Contact information

For more information, please visit: <http://www.nxp.com>

For sales office addresses, please send an email to: [salesaddresses@nxp.com](mailto:salesaddresses@nxp.com)

## 17. Contents

1	General description . . . . .	1
2	Features and benefits . . . . .	1
3	Ordering information . . . . .	1
4	Functional diagram . . . . .	2
5	Pinning information . . . . .	3
5.1	Pinning . . . . .	3
5.2	Pin description . . . . .	3
6	Functional description . . . . .	5
7	Limiting values . . . . .	5
8	Recommended operating conditions . . . . .	5
9	Static characteristics . . . . .	6
10	Dynamic characteristics . . . . .	7
11	Waveforms . . . . .	8
12	Test information . . . . .	9
13	Package outline . . . . .	10
14	Revision history . . . . .	12
15	Legal information . . . . .	13
15.1	Data sheet status . . . . .	13
15.2	Definitions . . . . .	13
15.3	Disclaimers . . . . .	13
15.4	Trademarks . . . . .	14
16	Contact information . . . . .	14
17	Contents . . . . .	15

Please be aware that important notices concerning this document and the product(s) described herein, have been included in section 'Legal information'.

© NXP B.V. 2011.

All rights reserved.

For more information, please visit: <http://www.nxp.com>

For sales office addresses, please send an email to: [salesaddresses@nxp.com](mailto:salesaddresses@nxp.com)

Date of release: 3 November 2011

Document identifier: 74ABT16244A