

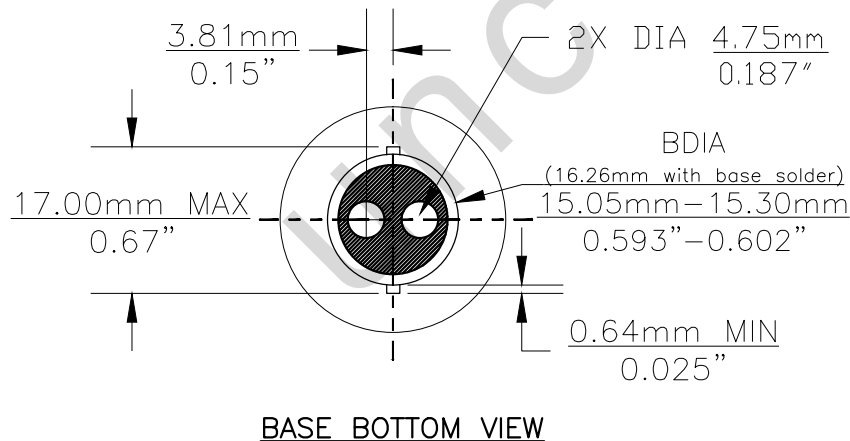

PART NO.	BASE TYPE	DESIGN VOLTS	DESIGN AMPS	MSCD	FILAMENT TYPE	AVERAGE LIFE HOURS	REVISIONS			
							REV #	DESCRIPTION	DATE	APPROVED
CE3	D.C. INDEX BAY15d (Nickel)	36V 36V	0.69±10% 0.27±10%	28±20% 5±20%	C-6 C-6	300 1000	1	REVISED FILAMENT TYPE	01/10/2005	D.C.
							2	REDRAWN	04/27/2016	R.M.
							3	REVISED HRS., CP, AMPS, BDIA	12/17/2019	R.M.

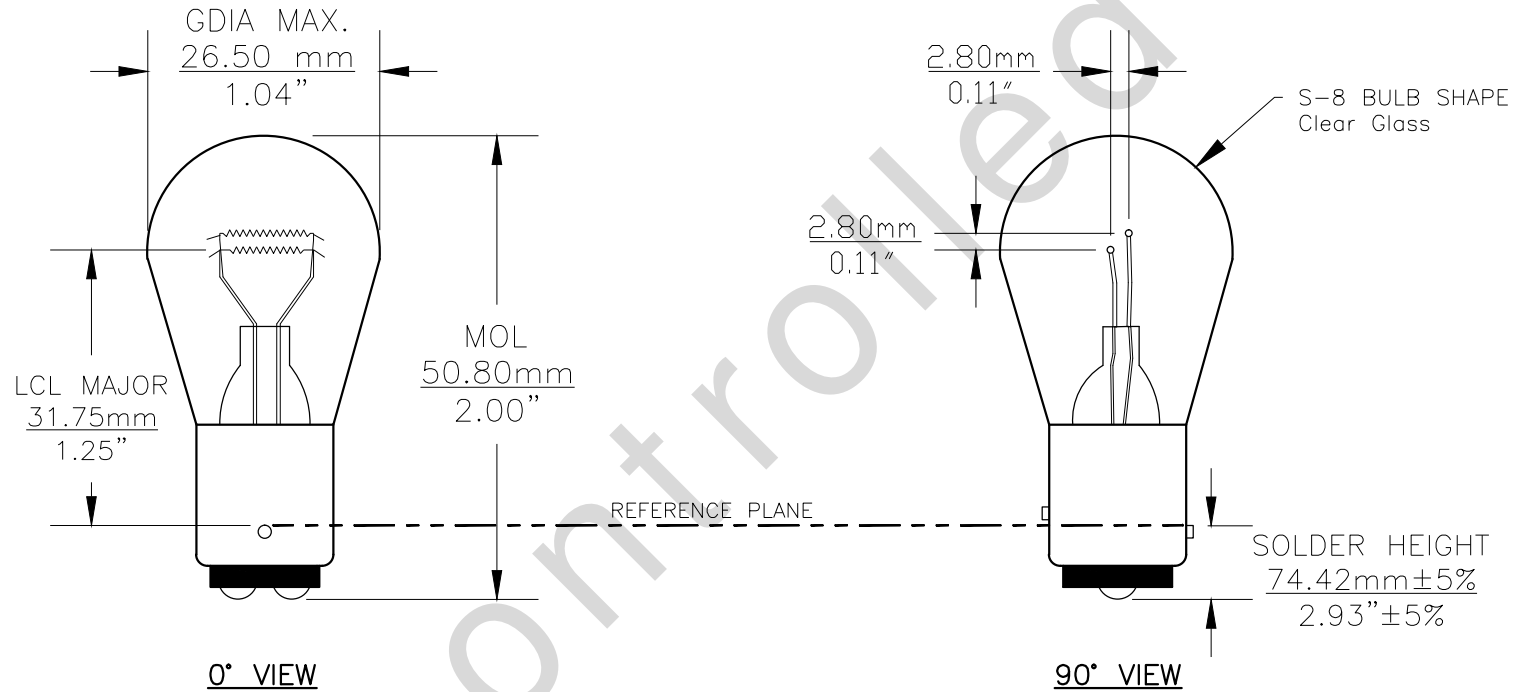

UNLESS OTHERWISE SPECIFIED: DIMENSIONS ARE IN INCHES TOLERANCES		CEC INDUSTRIES LTD			
DECIMALS .XX ± .05		FSCM NO.		DWG NO.	
ANGULAR .XXX ± .010		SCALE		PLOT SCALE	
FRACTIONAL ±1/64		FILE		SHEET 1 OF 1	
DRAWN DENNIS CLARK		DATE 12/23/2004		TITLE LIGHT BULB NO. CE3	
CHECKED		REV 3		DRAWING NOT TO SCALE	
DESIGN		MATERIAL		CE3.pdf	