

1 2 3 4 5 6 7 8

A

B

C

D

E

F

A

B

C

D

E

F

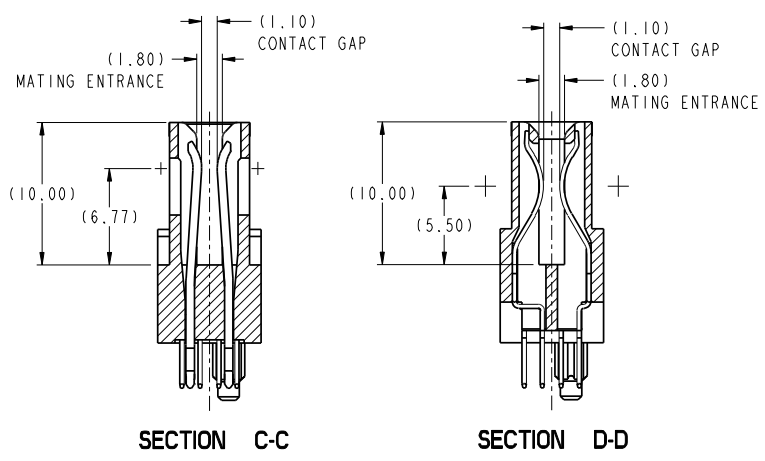
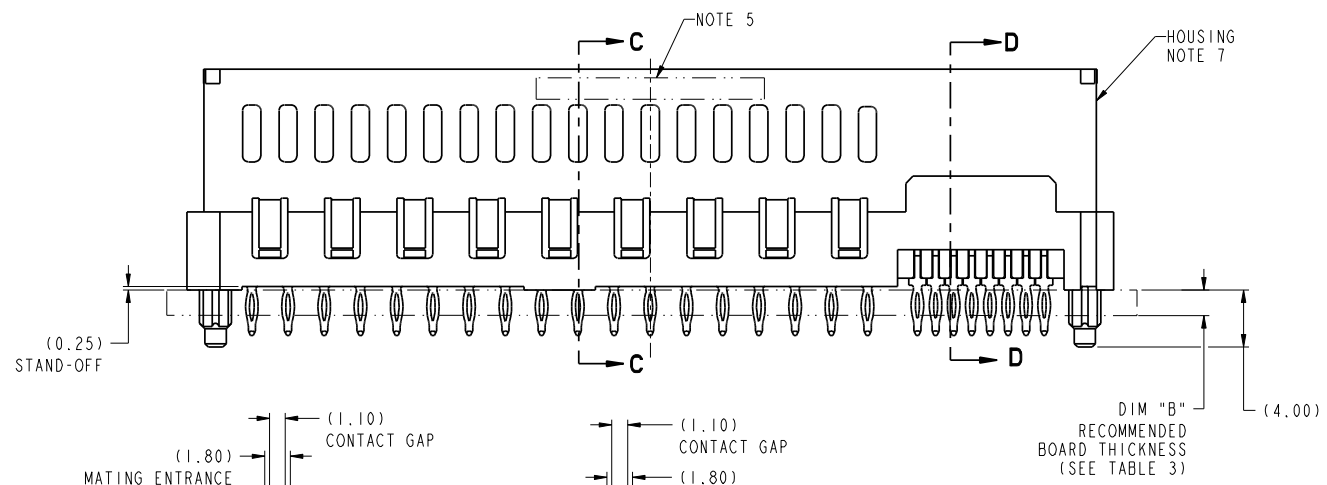
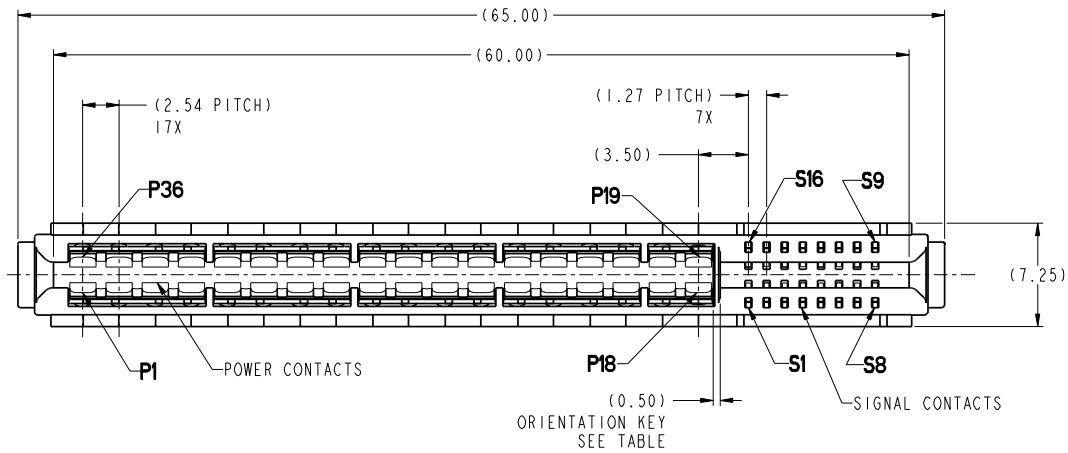

spec ref	-	dr	HELEN ZHANG	2011-07-19	projection	MM	size	A2	scale	4:1
tolerance std	ASME Y14.5	eng	WL ZHANG	2011-07-19	chr	WL ZHANG	2011-07-19	ecm no		
TOLERANCES UNLESS OTHERWISE SPECIFIED		appr	PM ZHENG	2011-07-19	product family	CARD EDGE	rel level	Released		
surface	linear	0.X	±0.3		<b>VERT RECT (36P-16S)</b> HIGH POWER CARD EDGE		10115567	rev A		
	linear	0.XX	±0.10		www.fcicom	col. no.	Product - Customer Drw	sheet 1 of 4		
	angular	0°	±2°							

Copyright FCI

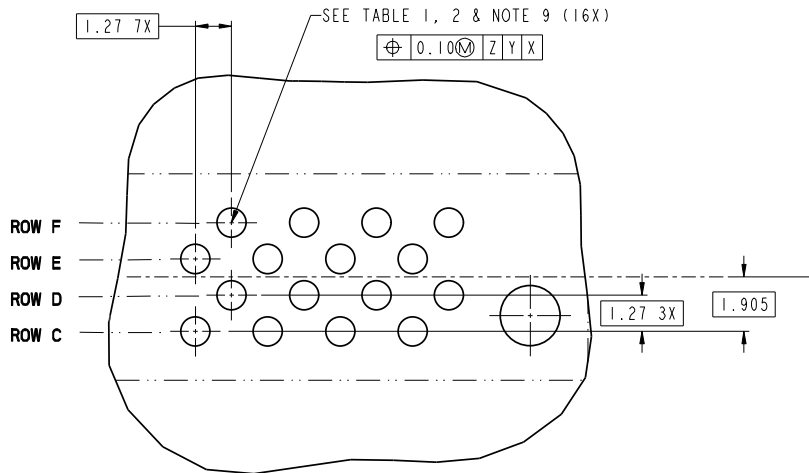
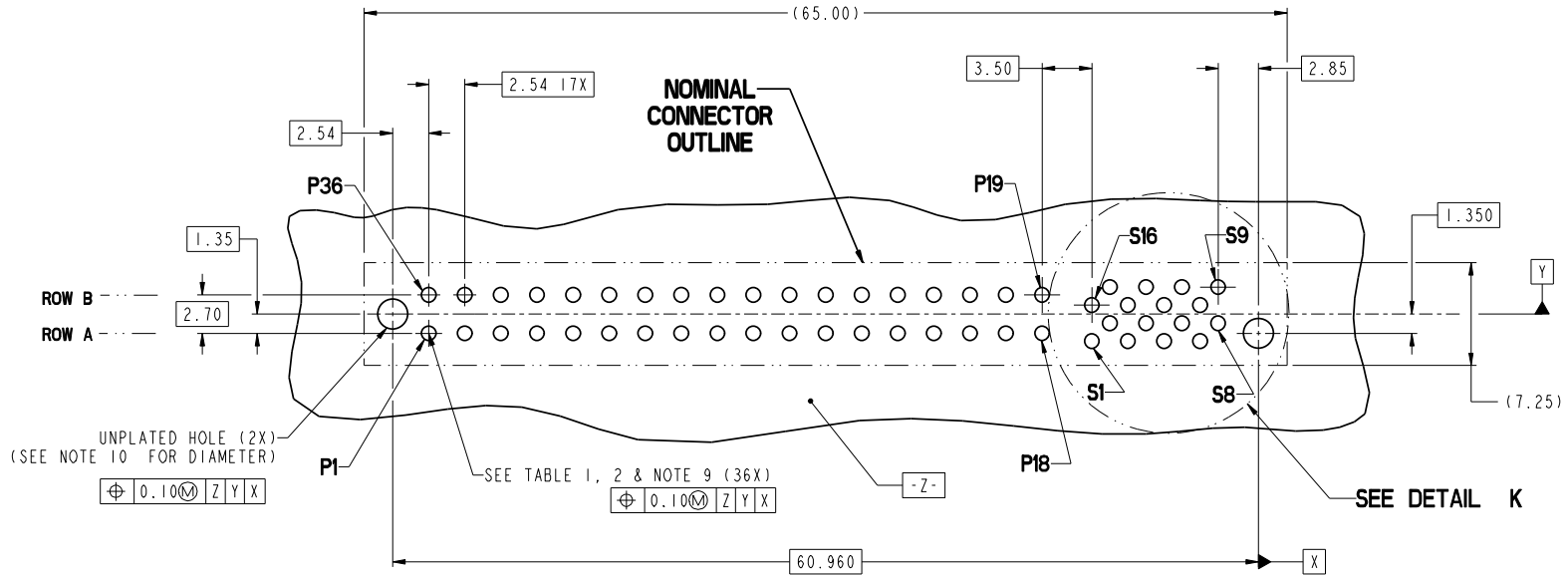

**DETAIL K**  
SCALE 8:1

**RECOMMENDED PCB LAYOUT  
VIEWED FROM CONNECTOR SIDE**

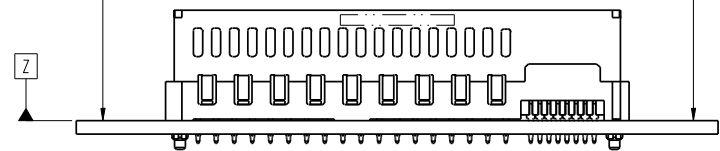

dr	HELEN ZHANG	2011-07-19	projection	MM	size	A2	scale	4:1
eng	WL ZHAGN	2011-07-19			ecm no.			
chr	WL ZHAGN	2011-07-19			product family	CARD EDGE	rel level	Released
appr	PM ZHENG	2011-07-19						
<b>VERT RECT (36P-16S)</b> HIGH POWER CARD EDGE			www.fcicom.com	col. no.	Product - Customer Drw	10115567	rev A	sheet 2 of 4

Copyright FCI.

CONTACT TYPE	TOP LAYER DESCRIPTION	TABLE 1 (HPCE / SOLDER TAILS) PLATED THROUGH-HOLE REQUIREMENTS				
		DRILLED HOLE DIAMETER	COPPER THICKNESS	TIN-LEAD THICKNESS	TIN THICKNESS	FINISHED HOLE DIAMETER
POWER & SIGNAL	TIN-LEAD	1.10-1.16 (1.15 DRILL)	0.025 - 0.050	0.005 - 0.015	--	0.94 - 1.10
	IMMERSION TIN	1.10-1.16 (1.15 DRILL)	0.025 - 0.050	--	0.9 - 1.5um	0.94 - 1.10
	COPPER (SEE NOTE 8)	1.10-1.16 (1.15 DRILL)	0.025 - 0.050	--	--	0.94 - 1.10

CONTACT TYPE	TOP LAYER DESCRIPTION	TABLE 2 (HPCE / PRESS-FIT TAILS) PLATED THROUGH-HOLE REQUIREMENTS				
		DRILLED HOLE DIAMETER	COPPER THICKNESS	TIN-LEAD THICKNESS	TIN THICKNESS	FINISHED HOLE DIAMETER
POWER & SIGNAL	TIN-LEAD	0.81-0.86 (0.85 DRILL)	0.025 - 0.050	0.005 - 0.015	--	0.65 - 0.80
	IMMERSION TIN	0.81-0.86 (0.85 DRILL)	0.025 - 0.050	--	0.9 - 1.5um	0.70 - 0.80
	COPPER (SEE NOTE 8)	0.81-0.86 (0.85 DRILL)	0.025 - 0.050	--	--	0.70 - 0.80

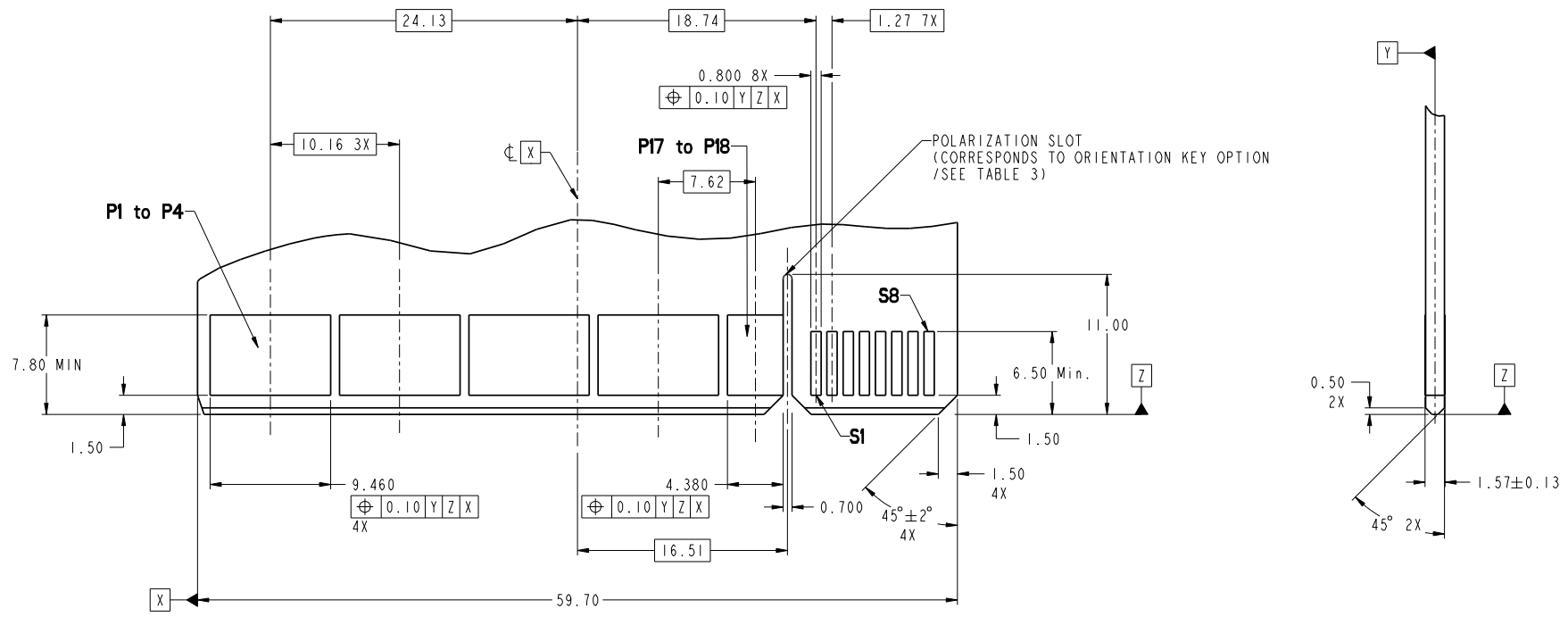

RECOMMENDED MATING BOARD FOOTPRINT

Copyright FCI

dr	HELEN ZHANG	2011-07-19	projection	MM	size	A2	scale	4:1
eng	WL ZHAGN	2011-07-19		CARD EDGE	ecm no			
chr	WL ZHAGN	2011-07-19			rel level	Released		
appr	PM ZHENG	2011-07-19	product family	VERT RECT (36P-16S)				
www.fcicom			cat. no.	Product - Customer Draw		10115567	rev	A
sheet 3 of 4								

HPCE PART NUMBER (TABLE 3)

PART NUMBER	TAIL TYPE	ORIENTATION KEY	DIM "A" TYPICAL TAIL LENGTH	DIM "B" RECOMMENDED BOARD THICKNESS
10115567-001LF	SOLDER	YES	3.17 ±0.25	1.59 - 2.38
10115567-002LF	SOLDER	NO		
10115567-003	PRESS-FIT	YES	3.17 ±0.25	1.57 MIN
10115567-003LF	PRESS-FIT	YES		
10115567-004	PRESS-FIT	NO		
10115567-004LF	PRESS-FIT	NO		

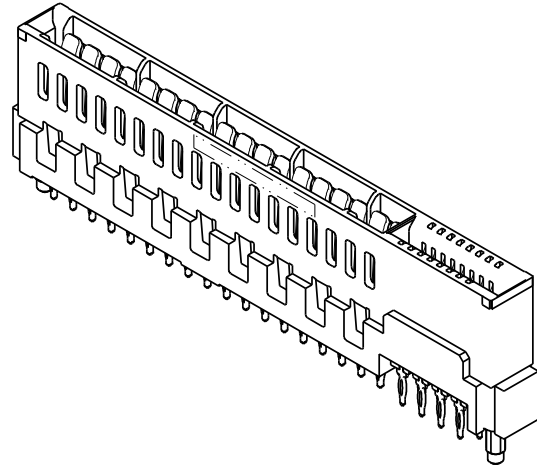

NOTES:

1. CONNECTOR MATERIALS:

HOUSING: HIGH TEMPERATURE THERMAL PLASTIC, BLACK  
UL 94V-0 COMPLIANT  
CONTACTS: HIGH PERFORMANCE COPPER ALLOY.

2. CONTACT FINISH REF. GS-12-604 SECTION 5.2.

3. PRODUCT SPECIFICATION: GS-12-604.

4. APPLICATION SPECIFICATION: GS-20-128.

5. PRODUCT MARKING (FCI - PART NUMBER & DATE CODE) ON HOUSING IN AREA SHOWN.

6. PACKAGING MEETS FCI SPECIFICATION GS-14-937.

7. HOUSING COMPONENT WILL WITHSTAND EXPOSURE TO 260°C PEAK TEMPERATURE FOR 60 SECONDS IN A CONVECTION, INFRA-RED, OR VAPOR PHASE REFLOW OVEN.

8. COPPER PLATING THICKNESS IN CENTER OF VIA-HOLE CAN BE NO MORE THAN 0.003 LESS THAN OTHER AREAS.

9. ALL HOLE SIZES ARE FINISHED HOLE SIZES.

10. MOUNTING HOLES ARE UNPLATED  
 Ø 2.40 +/- 0.1 FOR PRESS-FIT TAILS  
 Ø 2.10 +/- 0.1 FOR SOLDER TAILS

Copyright FCI.

dr	HELEN ZHANG	2011-07-19	projection	MM	size	A2	scale	4:1
eng	WL ZHAGN	2011-07-19		CARD EDGE	ecm no			
chr	WL ZHAGN	2011-07-19			rel level	Released		
appr	PM ZHENG	2011-07-19	product family		diag no	10115567	rev	A
www.fcicom			cat. no.	Product - Customer Drw		sheet 4 of 4		