



EV2615C-Q-00A

2A, 1- or 2-Cell Li-Ion Battery Charger Evaluation Board

DESCRIPTION

The EV2615C-Q-00A is an evaluation board for the MP2615C, a switching charger for 1- or 2-cell Li-ion or Li-polymer batteries. The MP2615C provides built-in power MOSFETs. The device can achieve up to 2A of charge current, which can be configured by an accurate sense resistor across the whole input range.

The MP2615C regulates the charge current and full battery voltage using two control loops for high-accuracy constant current (CC) charge and constant voltage (CV) charge.

Constant-off-time (COT) control allows a 99% duty cycle to be achieved when the battery voltage is close to the input voltage. This keeps the charge current at a relatively high level.

The battery temperature and charging status are always monitored for each condition. Two output pins indicate the battery charging status and input power status. The MP2615C also features internal reverse blocking protection.

The MP2615C is available in a QFN-16 (3mmx3mm) package.

ELECTRICAL SPECIFICATIONS

Parameter	Symbol	Value	Units
Input voltage	V_{IN}	4.75 to 18	V
Battery voltage	V_{BATT}	0 to 8.4	V
Charge current	I_{CHG}	2	A

FEATURES

- 4.75V to 18V Operating Input Voltage
- Up to 99% Duty Cycle Operation
- Up to 2A Configurable Charging Current
- $\pm 0.75\%$ Full Battery Voltage Accuracy
- 4.1V/Cell and 4.2V/Cell Selection for Full Battery Voltage
- Fully Integrated Power Switches
- Internal Loop Compensation
- No External Reverse Blocking Diode Required
- Preconditioning for Fully Depleted Battery
- Charging Operation Indicator
- Configurable Safety Timer
- Thermal Shutdown Protection
- Cycle-by-Cycle Over-Current Protection (OCP)
- Battery Temperature Monitoring and Protection
- Available in a QFN-16 (3mmx3mm) Package

APPLICATIONS

- Smartphones
- Portable Handheld Solutions
- Portable Media Players

All MPS parts are lead-free, halogen-free, and adhere to the RoHS directive. For MPS green status, please visit the MPS website under Quality Assurance. "MPS", the MPS logo, and "Simple, Easy Solutions" are trademarks of Monolithic Power Systems, Inc. or its subsidiaries.

EV2615C-Q-00A EVALUATION BOARD



LxWxH (6.3cmx6.3cmx0.16cm)

Board Number	MPS IC Number
EV2615C-Q-00A	MP2615CGQ

QUICK START GUIDE

This board evaluates applications using the MP2615C, a switching charger for 1- or 2-cell Li-ion or Li-polymer batteries. The MP2615C provides built-in power MOSFETs. The board layout accommodates most commonly used capacitors.

1. The EV2615C-Q-00A can select the number of battery cells. Set CELL to different logics to set the cells to different specifications. Table 1 shows how to set the number of battery cells through JP1, according to different application conditions.

Table 1: Setting the Number of Battery Cells through the CELL Pin

CELL	Number of Cells
High	1-cell ($V_{IN} = 4.75$ to $18V$)
Low/floating	2-cell ($V_{IN} = 8.75V$ to $18V$)

2. The EV2615C-Q-00A can also regulate the terminal battery voltage by setting the logic of the SEL pin. Table 2 shows how to set the terminal battery voltage specifications through JP2, according to different application conditions.

Table 2: Setting the Terminal Battery Voltage through the SEL Pin

SEL	Terminal Battery Voltage
High	4.1V/cell
Low/floating	4.2V/cell

3. JP3 sets the EN logic, which can force the MP2615C to shut down if V_{IN} is added. When EN is logic high, this means that EN can be connected to VCC through JP3 to disable the MP2615C. Float EN or connect it to GND to enable the part.
4. The constant charge current (I_{CC}) can be set by the sense resistor ($RS1$). I_{CC} can be calculated with Equation (1):

$$I_{CC} (A) = 50(mV) / RS1(m\Omega) \quad (1)$$

For example, if $RS1 = 25m\Omega$, $I_{CC} = 50(mV) / 25(m\Omega)$, or 2A.

The trickle charge current (I_{TC}) can be estimated with Equation (2):

$$I_{TC} = 0.1 \times I_{CC} = 5(mV) / RS1(m\Omega) \quad (2)$$

5. For more detailed application information, refer to the related datasheet.

EVALUATION BOARD SCHEMATIC

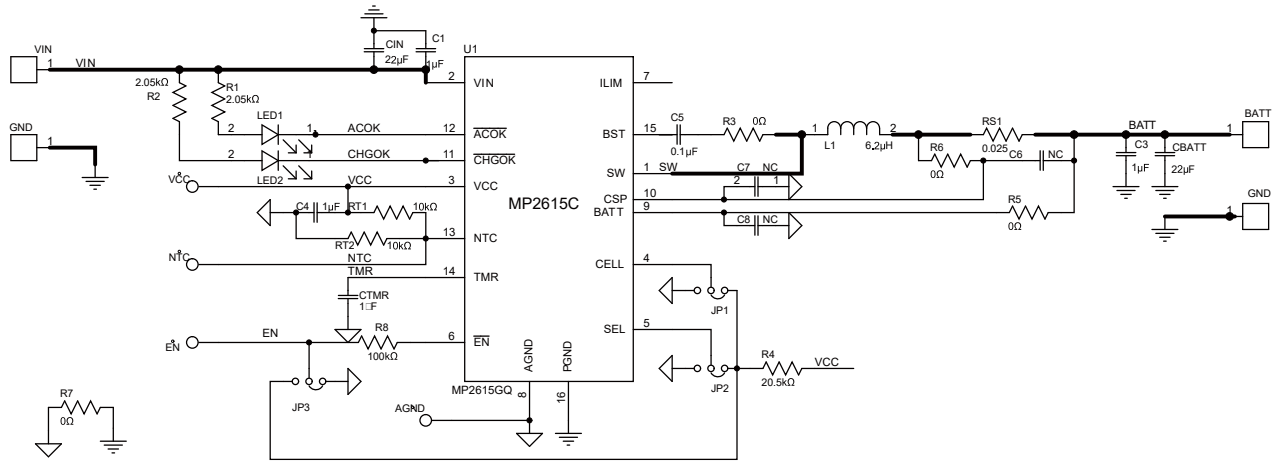

Figure 1: Evaluation Board Schematic

EV2615C-Q-00A BILL OF MATERIALS

Qty	Ref	Value	Description	Package	Manufacturer	Manufacturer P/N
4	C1, C3, C4, CTMR	1 μ F	Ceramic capacitor, 25V, X7R	0603	Murata	GRM188R71E105KA12 D
3	C6, C7, C8	NC				
1	C5	0.1 μ F	Ceramic capacitor, 16V, X7R, 0603	0603	Murata	GRM188R71C104KA01 D
2	RT1, RT2	10k Ω	Film resistor, 1%	0603	Yageo	RC0603FR-0710KL
2	R1, R2	2.05k Ω	Film resistor, 1%	0603	Yageo	RC0603FR-072K05L
1	R4	20.5k Ω	Film resistor, 1%	0603	Yageo	RC0603FR-0720K5L
4	R3, R5, R6, R7	0 Ω	Film resistor, 5%	0603	Yageo	RC0603JR-070RL
5	R8	100k Ω	Film resistor, 1%	0603	Yageo	RC0603FR-07100KL
1	LED2	BL- HUF35A- TRB	Red LED	0805	Bright LED	BL-HUF35A-TRB
1	LED1	BL- HGB35A- TRB	Green LED	0805	Bright LED	BL-HGB35A-TRB
2	CBATT, CIN	22 μ F	Ceramic capacitor, 25V, X5R	1206	Murata	GRM31CR61E226KE15
1	RS1	0.025 Ω	Film resistor, 1%, 1/4W	1206	Yageo	RL1206FR-070R025L
1	L1	6.2 μ H	Inductor, 6.2 μ H, 24m Ω , 4.3A	SMD	Wurth	7440660062
1	U1	MP2615C	Switching charger	QFN-16 (3mmx3mm)	MPS	MP2615CGQ
2	BATT, VIN		Connector			
3	JP1, JP2, JP3		Connector			

PCB LAYOUT

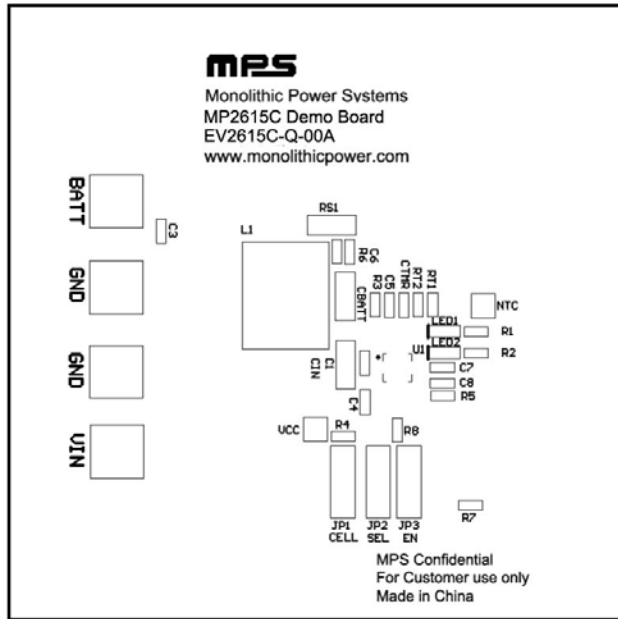

Figure 2: Top Silk Layer

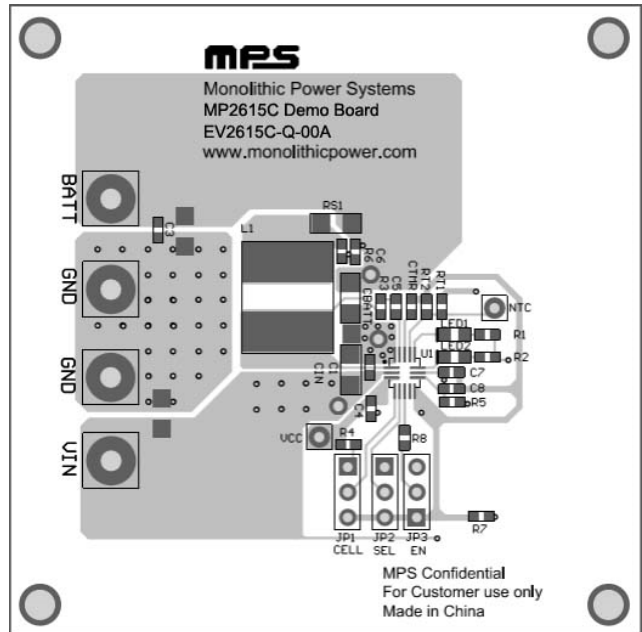

Figure 3: Top Layer

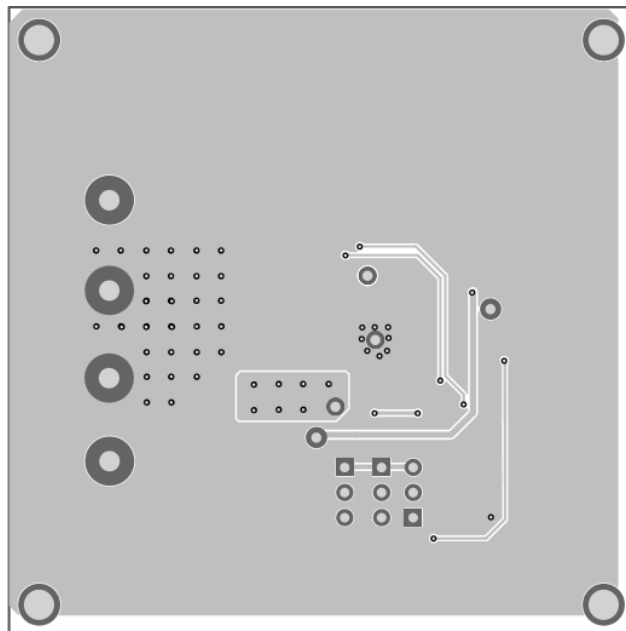

Figure 4: Bottom Layer

REVISION HISTORY

Revision #	Revision Date	Description	Pages Updated
1.0	1/25/2021	Initial Release	-

Notice: The information in this document is subject to change without notice. Users should warrant and guarantee that third-party Intellectual Property rights are not infringed upon when integrating MPS products into any application. MPS will not assume any legal responsibility for any said applications.