



CYD04S72V
CYD09S72V
CYD18S72V

FLEx72™ 3.3 V 64 K/128 K/256 K × 72 Synchronous Dual-Port RAM

Features

- True dual-ported memory cells that allow simultaneous access of the same memory location
- Synchronous pipelined operation
- Family of 4 Mbit, 9 Mbit, and 18 Mbit devices
- Pipelined output mode allows fast operation
- 0.18-micron complementary metal oxide semiconductor (CMOS) for optimum speed and power
- High-speed clock to data access
- 3.3 V low power
 - Active as low as 225 mA (typ)
 - Standby as low as 55 mA (typ)
- Mailbox function for message passing
- Global master reset
- Separate byte enables on both ports
- Commercial and industrial temperature ranges
- IEEE 1149.1-compatible joint test action group (JTAG) boundary scan
- 484-ball fine-pitch ball grid array (FBGA) (1-mm pitch)
- Pb-free packaging available
- Counter wrap around control
 - Internal mask register controls counter wrap-around
 - Counter-interrupt flags to indicate wrap-around
 - Memory block retransmit operation
- Counter readback on address lines
- Mask register readback on address lines
- Dual chip enables on both ports for easy depth expansion
- Seamless migration to next generation dual-port family

Functional Description

The FLEx72 family includes 4 Mbit, 9 Mbit and 18 Mbit pipelined, synchronous, true dual-port static RAMs that are high-speed, low-power 3.3 V CMOS. Two ports are provided, permitting independent, simultaneous access to any location in memory. The result of writing to the same location by more than one port at the same time is undefined. Registers on control, address, and data lines allow for minimal set-up and hold time.

During a Read operation, data is registered for decreased cycle time. Each port contains a burst counter on the input address register. After externally loading the counter with the initial address, the counter will increment the address internally (more details to follow). The internal write pulse width is independent of the duration of the R/W input signal. The internal write pulse is self-timed to allow the shortest possible cycle times.

A HIGH on $\overline{CE0}$ or LOW on CE1 for one clock cycle will power down the internal circuitry to reduce the static power consumption. One cycle with chip enables asserted is required to reactivate the outputs.

Additional features include: readback of burst-counter internal address value on address lines, counter-mask registers to control the counter wrap-around, counter interrupt (CNTINT) flags, readback of mask register value on address lines, retransmit functionality, interrupt flags for message passing, JTAG for boundary scan, and asynchronous Master Reset (MRST).

The CYD18S72V device have limited features. Please see [Table 3 on page 8](#) for details.

Seamless Migration to Next-Generation Dual-Port Family

Cypress offers a migration path for all devices to the next-generation devices in the Dual-Port family with a compatible footprint. Please contact Cypress Sales for more details

Table 1. Product Selection Guide

Density	4-Mbit (64K x 72)	9-Mbit (128K x 72)	18-Mbit (256K x 72)
Part number	CYD04S72V	CYD09S72V	CYD18S72V
Max. speed (MHz)	167	133	133
Max. access time—clock to data (ns)	4.0	4.4	5.0
Typical operating current (mA)	225	350	410
Package	484-ball FBGA 23 mm x 23 mm	484-ball FBGA 23 mm x 23 mm	484-ball FBGA 23 mm x 23 mm

Logic Block Diagram^[1]

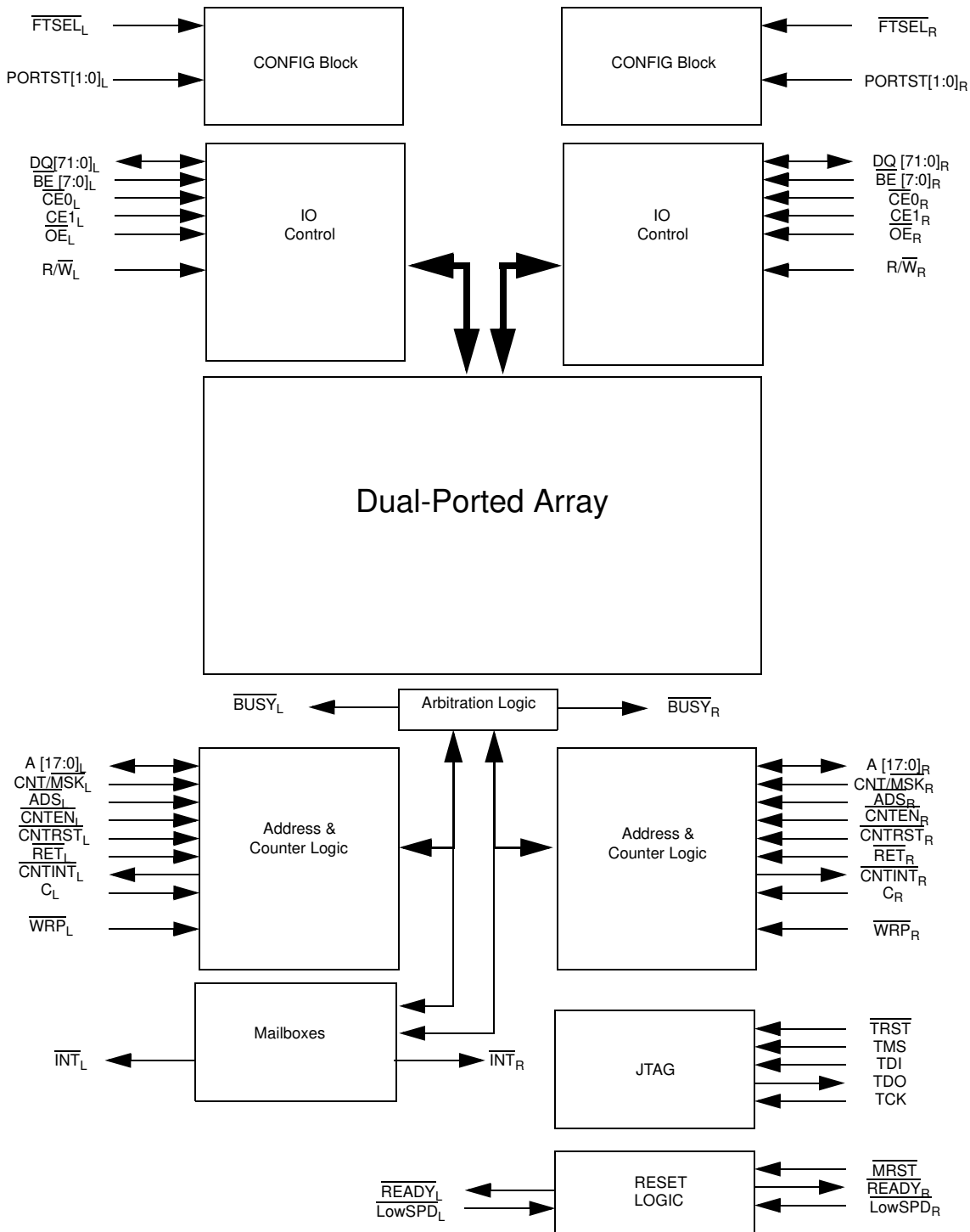

Note

1. CYD04S72V have 16 address bits, CYD09S72V have 17 address bits and CYD18S72V have 18 bits.

Contents

Pin Configuration	4	Maximum Ratings	13
Pin Definitions	5	Operating Range	13
Master Reset	7	Electrical Characteristics Over the Operating Range .	13
Mailbox Interrupts	7	Capacitance	14
Address Counter and Mask Register Operations	8	AC Test Load and Waveforms	14
Counter Reset Operation	8	Switching Characteristics Over the Operating Range .	14
Counter Load Operation	8	JTAG Timing Characteristics	16
Counter Increment Operation	9	Switching Waveforms	16
Counter Hold Operation	9	Ordering Information	26
Counter Interrupt	9	Ordering Code Definitions	26
Counter Readback Operation	9	Package Diagram	27
Retransmit	9	Acronyms	28
Mask Reset Operation	9	Document Conventions	28
Mask Load Operation	9	Units of Measure	28
Mask Readback Operation	9	Document History Page	29
Counting by Two	9	Sales, Solutions, and Legal Information	30
IEEE 1149.1 Serial Boundary Scan (JTAG)	11	Worldwide Sales and Design Support	30
Performing a TAP Reset	11	Products	30
Performing a Pause/Restart	11	PSoC Solutions	30
Boundary Scan Hierarchy for FLEx72 Family	11		

Pin Configuration

484-ball BGA Top View CYD04S72V/CYD09S72V/CYD18S72V																							
	1	2	3	4	5	6	7	8	9	10	11	12	13	14	15	16	17	18	19	20	21	22	
A	NC	DQ61L	DQ59L	DQ57L	DQ54L	DQ51L	DQ48L	DQ45L	DQ42L	DQ39L	DQ36L	DQ36R	DQ39R	DQ42R	DQ45R	DQ48R	DQ51R	DQ54R	DQ57R	DQ59R	DQ61R	NC	
B	DQ63L	DQ62L	DQ60L	DQ58L	DQ55L	DQ52L	DQ49L	DQ46L	DQ43L	DQ40L	DQ37L	DQ37R	DQ40R	DQ43R	DQ46R	DQ49R	DQ52R	DQ55R	DQ58R	DQ60R	DQ62R	DQ63R	
C	DQ65L	DQ64L	VSS	VSS	DQ56L	DQ53L	DQ50L	DQ47L	DQ44L	DQ41L	DQ38L	DQ38R	DQ41R	DQ44R	DQ47R	DQ50R	DQ53R	DQ56R	VSS	VSS	DQ64R	DQ65R	
D	DQ67L	DQ66L	VSS	VSS	VSS	NC ^[2,5]	NC ^[2,5]	VSS	LOWSP _{DL} ^[2,4]	PORTS _{TD0L} ^[2,4]	NC ^[2,5]	BUSYL _[2,5]	CNTINT _L ^[10]	PORTS _{TD1L} ^[2,4]	NC	NC ^[2,5]	NC ^[2,5]	VSS	VSS	VSS	DQ66R	DQ67R	
E	DQ69L	DQ68L	VDDIOL	VSS	VSS	VDDIOL	VDDIOL	VDDIOL	VDDIOL	VDDIOL	VDDIOL	VDDIOL	VDDIOL	VDDIOR	VDDIOR	VDDIOR	VDDIOR	NC	VSS	VDDIOR	DQ68R	DQ69R	
F	DQ71L	DQ70L	CE1L ^[8]	CE0L ^[9]	VDDIOL	VDDIOL	VDDIOL	VDDIOL	VDDIOL	VDDIOL	VDDIOL	VDDIOL	VDDIOL	VDDIOR	VDDIOR	VDDIOR	VDDIOR	VDDIOR	VDDIOR	CE0R ^[9]	CE1R ^[8]	DQ70R	DQ71R
G	A0L	A1L	RET _L ^[2,3]	BE4L	VDDIOL	VDDIOL	VREFL _[2,4]	VSS	VSS	VSS	VSS	VSS	VSS	VSS	VSS	VREFR _[2,4]	VDDIOR	VDDIOR	BE4R	RET _R ^[2,3]	A1R	A0R	
H	A2L	A3L	WRP _L ^[2,3]	BE5L	VDDIOL	VDDIOL	VSS	VSS	VSS	VSS	VSS	VSS	VSS	VSS	VSS	VSS	VDDIOR	VDDIOR	BE5R	WRP _R ^[2,3]	A3R	A2R	
J	A4L	A5L	READY _L ^[2,5]	BE6L	VDDIOL	VDDIOL	VSS	VSS	VSS	VSS	VSS	VSS	VSS	VSS	VSS	VSS	VDDIOR	VDDIOR	BE6R	READY _R ^[2,5]	A5R	A4R	
K	A6L	A7L	NC ^[2,5]	BE7L	VTTL	VCORE	VSS	VSS	VSS	VSS	VSS	VSS	VSS	VSS	VSS	VSS	VDDIOR	VDDIOR	BE7R	NC ^[2,5]	A7R	A6R	
L	A8L	A9L	CL	OEL	VTTL	VCORE	VSS	VSS	VSS	VSS	VSS	VSS	VSS	VSS	VSS	VSS	VDDIOR	VDDIOR	OER	CR	A9R	A8R	
M	A10L	A11L	VSS	BE3L	VTTL	VCORE	VSS	VSS	VSS	VSS	VSS	VSS	VSS	VSS	VSS	VSS	VDDIOR	VDDIOR	BE3R	VSS	A11R	A10R	
N	A12L	A13L	ADSL ^[9]	BE2L	VDDIOL	VDDIOL	VSS	VSS	VSS	VSS	VSS	VSS	VSS	VSS	VSS	VSS	VDDIOR	VDDIOR	BE2R	ADSR ^[9]	A13R	A12R	
P	A14L	A15L	CNTMS _{KL} ^[8]	BE1L	VDDIOL	VDDIOL	VSS	VSS	VSS	VSS	VSS	VSS	VSS	VSS	VSS	VSS	VDDIOR	VDDIOR	BE1R	CNTMS _{KR} ^[8]	A15R	A14R	
R	A16L _[6]	A17L _[7]	CNTENL _[9]	BE0L	VDDIOL	VDDIOL	VSS	VSS	VSS	VSS	VSS	VSS	VSS	VSS	VSS	VSS	VDDIOR	VDDIOR	BE0R	CNTENR _[9]	A17R _[7]	A16R _[6]	
T	A18L _[2,5]	NC	CNTRST _L ^[8]	INTL	VDDIOL	VDDIOL	VREFL _[2,4]	VSS	VSS	VSS	VSS	VSS	VSS	VSS	VSS	VREFR _[2,4]	VDDIOR	VDDIOR	INTR	CNTRST _R ^[8]	NC	A18R _[2,5]	
U	DQ35L	DQ34L	R/WL	REVL _[2,4]	VDDIOL	VDDIOL	VDDIOL	VDDIOL	VDDIOL	VDDIOL	VDDIOL	VDDIOL	VDDIOL	VDDIOR	VDDIOR	VDDIOR	VDDIOR	VDDIOR	VDDIOR	REV _R ^[2,4]	R/WR	DQ34R	DQ35R
V	DQ33L	DQ32L	FTSELL _[2,3]	VDDIOL	NC	VDDIOL	VDDIOL	VDDIOL	VDDIOL	VTTL	VTTL	VTTL	VDDIOR	VDDIOR	VDDIOR	VDDIOR	VDDIOR	VDDIOR	TRST _[2,5]	VDDIOR	FTSEL _R	DQ32R	DQ33R
W	DQ31L	DQ30L	VSS	MRST	VSS	NC ^[2,5]	NC ^[2,5]	REVL _[2,4]	PORTS _{TD1R} ^[2,4]	CNTINT _R ^[10]	BUSYR _[2,5]	NC ^[2,5]	PORTS _{TD0R} ^[2,4]	LOWSP _{DR} ^[2,4]	VSS	NC ^[2,5]	NC ^[2,5]	VSS	TDI	TDO	DQ30R	DQ31R	
Y	DQ29L	DQ28L	VSS	VSS	DQ20L	DQ17L	DQ14L	DQ11L	DQ8L	DQ5L	DQ2L	DQ2R	DQ5R	DQ8R	DQ11R	DQ14R	DQ17R	DQ20R	TMS	TCK	DQ28R	DQ29R	
AA	DQ27L	DQ26L	DQ24L	DQ22L	DQ19L	DQ16L	DQ13L	DQ10L	DQ7L	DQ4L	DQ1L	DQ1R	DQ4R	DQ7R	DQ10R	DQ13R	DQ16R	DQ19R	DQ22R	DQ24R	DQ26R	DQ27R	
AB	NC	DQ25L	DQ23L	DQ21L	DQ18L	DQ15L	DQ12L	DQ9L	DQ6L	DQ3L	DQ0L	DQ0R	DQ3R	DQ6R	DQ9R	DQ12R	DQ15R	DQ18R	DQ21R	DQ23R	DQ25R	NC	

Notes

- This ball will represent a next generation Dual-Port feature. For more information about this feature, contact Cypress Sales.
- Connect this ball to VDDIO. For more information about this next generation Dual-Port feature contact Cypress Sales.
- Connect this ball to VSS. For more information about this next generation Dual-Port feature, contact Cypress Sales.
- Leave this ball unconnected. For more information about this feature, contact Cypress Sales.
- Leave this ball unconnected for a 64K x 72 configuration.
- Leave this ball unconnected for 128K x 72 and 64K x72 configurations.
- These balls are not applicable for CYD18S72V device. They need to be tied to VDDIO.
- These balls are not applicable for CYD18S72V device. They need to be tied to VSS.
- These balls are not applicable for CYD18S72V device. They need to be no connected.

Pin Definitions

Left Port	Right Port	Description
$A_{0L}-A_{17L}$	$A_{0R}-A_{17R}$	Address inputs.
$\overline{BE}_{0L}-\overline{BE}_{7L}$	$\overline{BE}_{0R}-\overline{BE}_{7R}$	Byte enable inputs. Asserting these signals enables Read and Write operations to the corresponding bytes of the memory array.
$\overline{BUSY}_L^{[11,12]}$	$\overline{BUSY}_R^{[11,12]}$	Port busy output. When the collision is detected, a \overline{BUSY} is asserted.
C_L	C_R	Input clock signal.
$\overline{CE}_{0L}^{[13]}$	$\overline{CE}_{0R}^{[13]}$	Active low chip enable input.
$CE_{1L}^{[14]}$	$CE_{1R}^{[14]}$	Active high chip enable input.
$DQ_{0L}-DQ_{71L}$	$DQ_{0R}-DQ_{71R}$	Data bus input/output.
\overline{OE}_L	\overline{OE}_R	Output enable input. This asynchronous signal must be asserted LOW to enable the DQ data pins during Read operations.
\overline{INT}_L	\overline{INT}_R	Mailbox interrupt flag output. The mailbox permits communications between ports. The upper two memory locations can be used for message passing. \overline{INT}_L is asserted LOW when the right port writes to the mailbox location of the left port, and vice versa. An interrupt to a port is deasserted HIGH when it reads the contents of its mailbox.
$\overline{LowSPD}_L^{[11,15]}$	$\overline{LowSPD}_R^{[11,15]}$	Port low speed select input. When operating at less than 100 MHz, the \overline{LowSPD} disables the port DLL.
$PORTSTD_{j[1:0]}L^{[11,15]}$	$PORTSTD_{j[1:0]}R^{[11,15]}$	Port address/control/data i/o standard select input.
R/\overline{W}_L	R/\overline{W}_R	Read/write enable input. Assert this pin LOW to write to, or HIGH to Read from the dual-port memory array.
$\overline{READY}_L^{[11,12]}$	$\overline{READY}_R^{[11,12]}$	Port ready output. This signal will be asserted when a port is ready for normal operation.
$CNT/\overline{MSK}_L^{[14]}$	$CNT/\overline{MSK}_R^{[14]}$	Port counter/mask select input. Counter control input.
$\overline{ADS}_L^{[13]}$	$\overline{ADS}_R^{[13]}$	Port counter address load strobe input. Counter control input.
$\overline{CNTEN}_L^{[13]}$	$\overline{CNTEN}_R^{[13]}$	Port counter enable input. Counter control input.
$\overline{CNTRST}_L^{[14]}$	$\overline{CNTRST}_R^{[14]}$	Port counter reset input. Counter control input.
$\overline{CNTINT}_L^{[16]}$	$\overline{CNTINT}_R^{[16]}$	Port counter interrupt output. This pin is asserted LOW when the unmasked portion of the counter is incremented to all "1s".
$\overline{WRP}_L^{[11,17]}$	$\overline{WRP}_R^{[11,17]}$	Port counter wrap input. After the burst counter reaches the maximum count, if \overline{WRP} is low, the unmasked counter bits will be set to 0. If high, the counter will be loaded with the value stored in the mirror register.
$\overline{RET}_L^{[11,17]}$	$\overline{RET}_R^{[12,17]}$	Port counter retransmit input. Counter control input.
$\overline{FTSEL}_L^{[11,17]}$	$\overline{FTSEL}_R^{[11,17]}$	Flow-through select. Use this pin to select Flow-Through mode. When is de-asserted, the device is in pipelined mode.
$VREF_L^{[11,15]}$	$VREF_R^{[11,15]}$	Port external high-speed io reference input.

Notes

11. This ball will represent a next generation Dual-Port feature. For more information about this feature, contact Cypress Sales.
12. Leave this ball unconnected. For more information about this feature, contact Cypress Sales.
13. These balls are not applicable for CYD18S72V device. They need to be tied to VSS.
14. These balls are not applicable for CYD18S72V device. They need to be tied to VDDIO.
15. Connect this ball to VSS. For more information about this next generation Dual-Port feature, contact Cypress Sales.
16. These balls are not applicable for CYD18S72V device. They need to be no connected.
17. Connect this ball to VDDIO. For more information about this next generation Dual-Port feature contact Cypress Sales

Pin Definitions (continued)

Left Port	Right Port	Description
VDDIO _L	VDDIO _R	Port IO power supply.
REV ^[18,19] _L	REV ^[18,19] _R	Reserved pins for future features.
$\overline{\text{MRST}}$		Master reset input. $\overline{\text{MRST}}$ is an asynchronous input signal and affects both ports. A master reset operation is required at power-up.
TRST ^[18,20]		JTAG reset input.
TMS		JTAG test mode select input. It controls the advance of JTAG TAP state machine. State machine transitions occur on the rising edge of TCK.
TDI		JTAG test data input. Data on the TDI input will be shifted serially into selected registers.
TCK		JTAG test clock input.
TDO		JTAG test data output. TDO transitions occur on the falling edge of TCK. TDO is normally three-stated except when captured data is shifted out of the JTAG TAP.
V _{SS}		Ground inputs.
V _{CORE} ^[21]		Core power supply.
V _{TTL}		LVTTTL power supply.

Notes

18. This ball will represent a next generation Dual-Port feature. For more information about this feature, contact Cypress Sales.

19. Connect this ball to VSS. For more information about this next generation Dual-Port feature, contact Cypress Sales

20. Leave this ball unconnected. For more information about this feature, contact Cypress Sales.

21. This family of Dual-Ports does not use V_{CORE}, and these pins are internally NC. The next generation Dual-Port family, the FLEx72-E™, will use V_{CORE} of 1.5 V or 1.8 V. Please contact local Cypress FAE for more information

Master Reset

The FLEx72 family devices undergo a complete reset by taking the MRST input LOW. MRST input can switch asynchronously to the clocks. MRST initializes the internal burst counters to zero, and the counter mask registers to all ones (completely unmasked). MRST also forces the mailbox interrupt (INT) flags and the Counter Interrupt (CNTINT) flags HIGH. MRST must be performed on the FLEx72 family devices after power-up.

Mailbox Interrupts

The upper two memory locations may be used for message passing and permit communications between ports. Table 2 shows the interrupt operation for both ports using 18 Mbit device as an example. The highest memory location, 3FFFF is the mailbox for the right port and 3FFFE is the mailbox for the left port. Table 2 shows that in order to set the INT_R flag, a write

operation by the left port to address 3FFFF will assert INT_R LOW. At least one byte has to be active for a write to generate an interrupt. A valid Read of the 3FFFF location by the right port will reset INT_R HIGH. At least one byte has to be active in order for a read to reset the interrupt. When one port writes to the other port's mailbox, the INT of the port that the mailbox belongs to is asserted LOW.

The INT is reset when the owner (port) of the mailbox reads the contents of the mailbox. The interrupt flag is set in a flow-thru mode (i.e., it follows the clock edge of the writing port). Also, the flag is reset in a flow-thru mode (i.e., it follows the clock edge of the reading port)

Each port can read the other port's mailbox without resetting the interrupt. And each port can write to its own mailbox without setting the interrupt. If an application does not require message passing, INT pins should be left open.









Table 2. Interrupt Operation Example [22, 23, 24, 25]

Function	Left Port				Right Port			
	R/W _L	CE _L	A _{0L-17L}	INT _L	R/W _R	CE _R	A _{0R-17R}	INT _R
Set Right INT _R Flag	L	L	3FFFF	X	X	X	X	L
Reset Right INT _R Flag	X	X	X	X	H	L	3FFFF	H
Set Left INT _L Flag	X	X	X	L	L	L	3FFFE	X
Reset Left INT _L Flag	H	L	3FFFE	H	X	X	X	X

Notes

- 22. CYD04S72V have 16 address bits, CYD09S72V have 17 address bits and CYD18S72V have 18 bits.
- 23. CE is internal signal. CE = LOW if CE₀ = LOW and CE₁ = HIGH. For a single Read operation, CE only needs to be asserted once at the rising edge of the CLK and can be deasserted after that. Data will be out after the following CLK edge and will be three-stated after the next CLK edge.
- 24. OE is "Don't Care" for mailbox operation.
- 25. At least one of BE0 or BE7 must be LOW.

Table 3. Address Counter and Counter Mask Register Control Operation (Any Port) ^[26,27]

CLK	MRST	CNT/MSK	CNTRST	ADS	CNTEN	Operation	Description
X	L	X	X	X	X	Master Reset	Reset address counter to all 0s and mask register to all 1s
	H	H	L	X	X	Counter Reset	Reset counter unmasked portion to all 0s
	H	H	H	L	L	Counter Load	Load counter with external address value presented on address lines
	H	H	H	L	H	Counter Readback	Read out counter internal value on address lines
	H	H	H	H	L	Counter Increment	Internally increment address counter value
	H	H	H	H	H	Counter Hold	Constantly hold the address value for multiple clock cycles
	H	L	L	X	X	Mask Reset	Reset mask register to all 1s
	H	L	H	L	L	Mask Load	Load mask register with value presented on the address lines
	H	L	H	L	H	Mask Readback	Read out mask register value on address lines
	H	L	H	H	X	Reserved	Operation undefined

Address Counter and Mask Register Operations^[28]

This section describes the features only apply to 4 Mbit and 9 Mbit devices, not to 18 Mbit device. Each port has a programmable burst address counter. The burst counter contains three registers: a counter register, a mask register, and a mirror register.

The **counter register** contains the address used to access the RAM array. It is changed only by the Counter Load, Increment, Counter Reset, and by master reset (MRST) operations.

The **mask register** value affects the Increment and Counter Reset operations by preventing the corresponding bits of the counter register from changing. It also affects the counter interrupt output (CNTINT). The mask register is changed only by the Mask Load and Mask Reset operations, and by the MRST. The mask register defines the counting range of the counter register. It divides the counter register into two regions: zero or more “0s” in the most significant bits define the masked region, one or more “1s” in the least significant bits define the unmasked region. Bit 0 may also be “0,” masking the least significant counter bit and causing the counter to increment by two instead of one.

The **mirror register** is used to reload the counter register on increment operations (see “retransmit,” below). It always contains the value last loaded into the counter register, and is changed only by the Counter Load, and Counter Reset operations, and by the MRST.

Table 3 summarizes the operation of these registers and the required input control signals. The MRST control signal is asynchronous. All the other control signals in Table 3 (CNT/MSK, CNTRST, ADS, CNTEN) are synchronized to the port’s CLK. All these counter and mask operations are independent of the port’s chip enable inputs (CE0 and CE1).

Counter enable (CNTEN) inputs are provided to stall the operation of the address input and utilize the internal address generated by the internal counter for fast, interleaved memory applications. A port’s burst counter is loaded when the port’s address strobe (ADS) and CNTEN signals are LOW. When the port’s CNTEN is asserted and the ADS is deasserted, the address counter will increment on each LOW to HIGH transition of that port’s clock signal. This will Read/Write one word from/into each successive address location until CNTEN is deasserted. The counter can address the entire memory array, and will loop back to the start. Counter reset (CNTRST) is used to reset the unmasked portion of the burst counter to 0s. A counter-mask register is used to control the counter wrap.

Counter Reset Operation

All unmasked bits of the counter and mirror registers are reset to “0.” All masked bits remain unchanged. A Mask Reset followed by a Counter Reset will reset the counter and mirror registers to 00000, as will master reset (MRST).

Counter Load Operation

The address counter and mirror registers are both loaded with the address value presented at the address lines.

Notes

26. X” = “Don’t Care,” “H” = HIGH, “L” = LOW.

27. Counter operation and mask register operation is independent of chip enables.

28. The CYD04S72V has 16 address bits and a maximum address value of FFFF. The CYD09S72V has 17 address bits and a maximum address value of 1FFFF. The CYD18S72V has 18 address bits and a maximum address value of 3FFFF.

Counter Increment Operation

Once the address counter register is initially loaded with an external address, the counter can internally increment the address value, potentially addressing the entire memory array. Only the unmasked bits of the counter register are incremented. The corresponding bit in the mask register must be a “1” for a counter bit to change. The counter register is incremented by 1 if the least significant bit is unmasked, and by 2 if it is masked. If all unmasked bits are “1,” the next increment will wrap the counter back to the initially loaded value. If an Increment results in all the unmasked bits of the counter being “1s,” a counter interrupt flag (CNTINT) is asserted. The next Increment will return the counter register to its initial value, which was stored in the mirror register. The counter address can instead be forced to loop to 0000 by externally connecting CNTINT to CNTRST.^[29] An increment that results in one or more of the unmasked bits of the counter being “0” will de-assert the counter interrupt flag. The example in [Figure 2](#) shows the counter mask register loaded with a mask value of 0003Fh unmasking the first 6 bits with bit “0” as the LSB and bit “16” as the MSB. The maximum value the mask register can be loaded with is 1FFFFh. Setting the mask register to this value allows the counter to access the entire memory space. The address counter is then loaded with an initial value of 8h. The base address bits (in this case, the 6th address through the 16th address) are loaded with an address value but do not increment once the counter is configured for increment operation. The counter address will start at address 8h. The counter will increment its internal address value till it reaches the mask register value of 3Fh. The counter wraps around the memory block to location 8h at the next count. CNTINT is issued when the counter reaches its maximum value.

Counter Hold Operation

The value of all three registers can be constantly maintained unchanged for an unlimited number of clock cycles. Such operation is useful in applications where wait states are needed, or when address is available a few cycles ahead of data in a shared bus interface.

Counter Interrupt

The counter interrupt (CNTINT) is asserted LOW when an increment operation results in the unmasked portion of the counter register being all “1s.” It is deasserted HIGH when an Increment operation results in any other value. It is also de-asserted by Counter Reset, Counter Load, Mask Reset and Mask Load operations, and by MRST.

Counter Readback Operation

The internal value of the counter register can be read out on the address lines. Readback is pipelined; the address will be valid t_{CA2} after the next rising edge of the port's clock. If address readback occurs while the port is enabled (CE0 LOW and CE1 HIGH), the data lines (DQs) will be three-stated. [Figure 1](#) shows a block diagram of the operation.

Retransmit

Retransmit is a feature that allows the Read of a block of memory more than once without the need to reload the initial address.

Note

29. CNTINT and CNTRST specs are guaranteed by design to operate properly at speed grade operating frequency when tied together.

This eliminates the need for external logic to store and route data. It also reduces the complexity of the system design and saves board space. An internal “mirror register” is used to store the initially loaded address counter value. When the counter unmasked portion reaches its maximum value set by the mask register, it wraps back to the initial value stored in this “mirror register.” If the counter is continuously configured in increment mode, it increments again to its maximum value and wraps back to the value initially stored into the “mirror register.” Thus, the repeated access of the same data is allowed without the need for any external logic.

Mask Reset Operation

The mask register is reset to all “1s,” which unmasks every bit of the counter. Master reset (MRST) also resets the mask register to all “1s.”

Mask Load Operation

The mask register is loaded with the address value presented at the address lines. Not all values permit correct increment operations. Permitted values are of the form 2^n-1 or 2^n-2 . From the most significant bit to the least significant bit, permitted values have zero or more “0s,” one or more “1s,” or one “0.” Thus 1FFFF, 003FE, and 00001 are permitted values, but 1FOFF, 003FC, and 00000 are not.

Mask Readback Operation

The internal value of the mask register can be read out on the address lines. Readback is pipelined; the address will be valid t_{CM2} after the next rising edge of the port's clock. If mask readback occurs while the port is enabled (CE0 LOW and CE1 HIGH), the data lines (DQs) will be three-stated. [Figure 1](#) shows a block diagram of the operation.

Counting by Two

When the least significant bit of the mask register is “0,” the counter increments by two. This may be used to connect the x72 devices as a 144-bit single port SRAM in which the counter of one port counts even addresses and the counter of the other port counts odd addresses. This even-odd address scheme stores one half of the 144-bit data in even memory locations, and the other half in odd memory locations.

Figure 1. Counter, Mask, and Mirror Logic Block Diagram^[30]

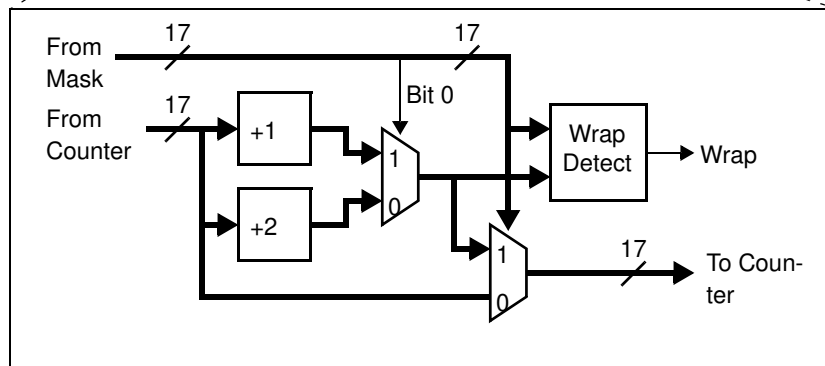
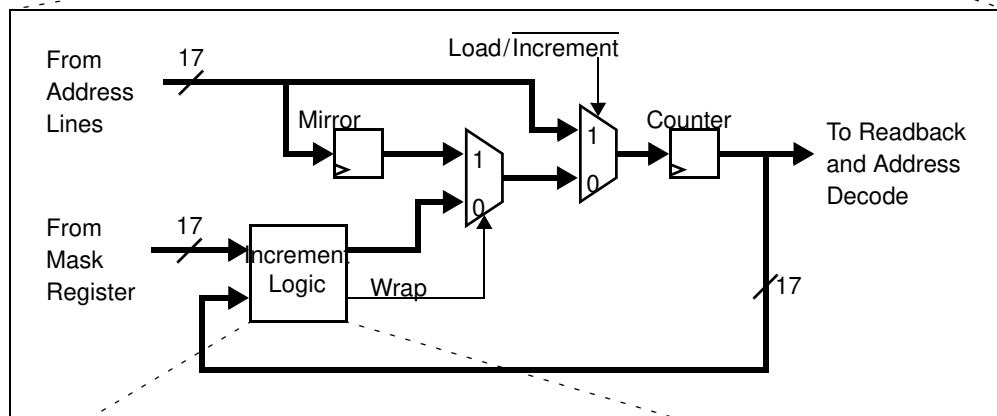
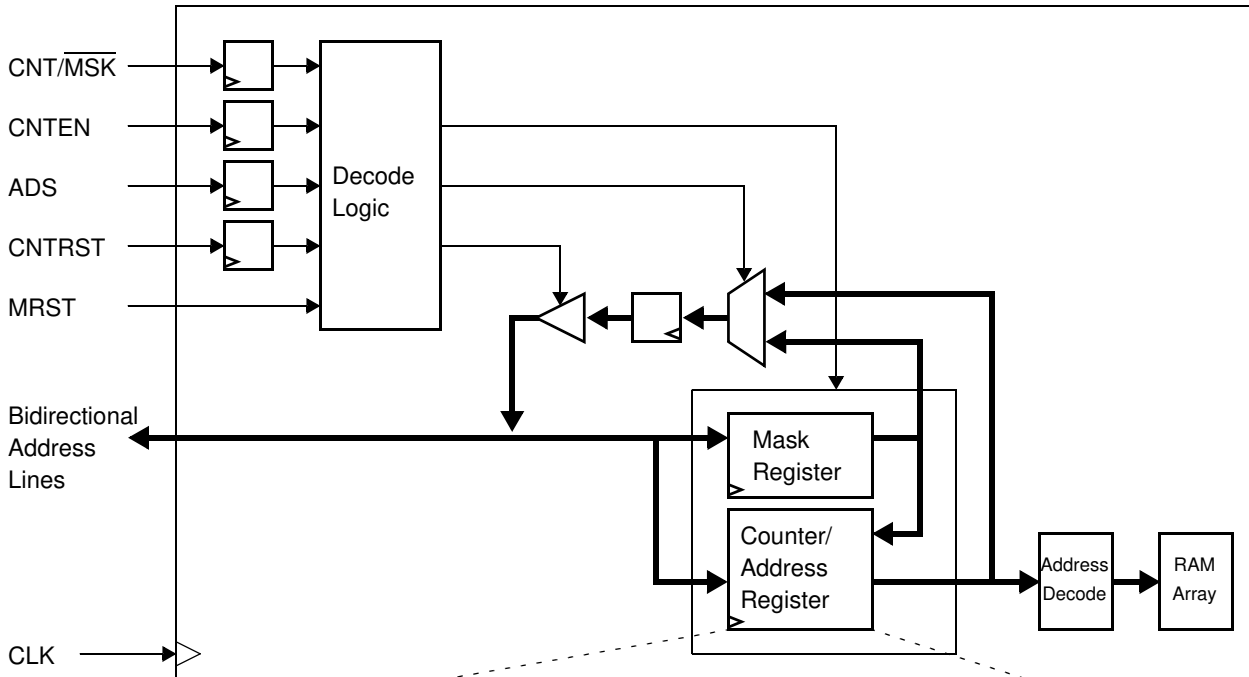

Note
30. CYD04S72V have 16 address bits, CYD09S72V have 17 address bits and CYD18S72V have 18 bits.

Figure 2. Programmable Counter-Mask Register Operation^[31, 32]

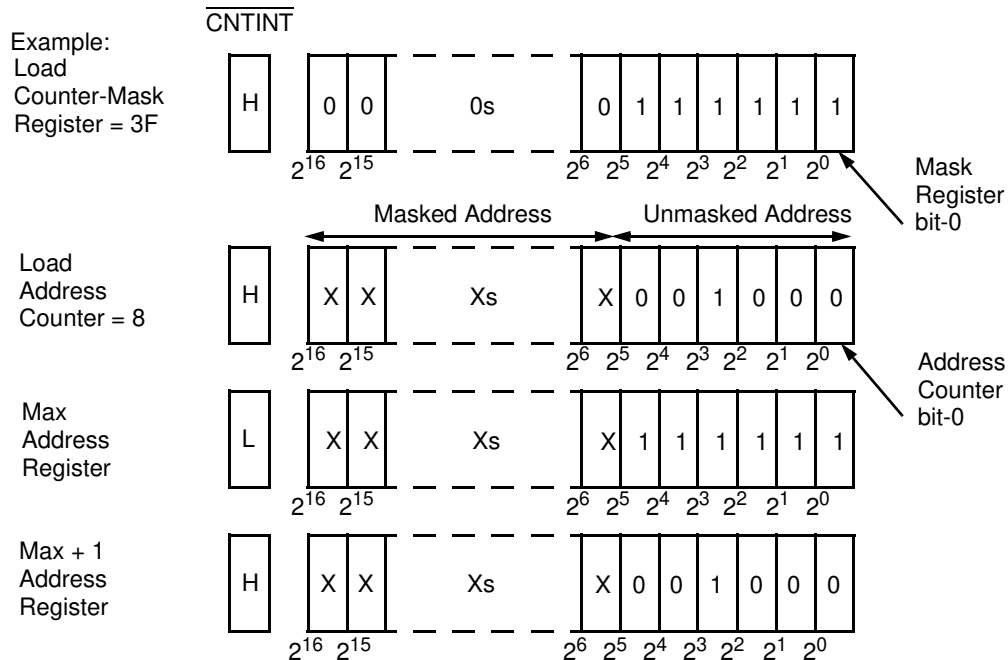

IEEE 1149.1 Serial Boundary Scan (JTAG)^[33]

The FLEx72 incorporates an IEEE 1149.1 serial boundary scan test access port (TAP). The TAP controller functions in a manner that does not conflict with the operation of other devices using 1149.1-compliant TAPs. The TAP operates using JEDEC-standard 3.3 V I/O logic levels. It is composed of three input connections and one output connection required by the test logic defined by the standard.

Performing a TAP Reset

A reset is performed by forcing TMS HIGH (V_{DD}) for five rising edges of TCK. This reset does not affect the operation of the FLEx72 family and may be performed while the device is operating. An MRST must be performed on the FLEx72 after power-up.

Performing a Pause/Restart

When a SHIFT-DR PAUSE-DR SHIFT-DR is performed the scan chain will output the next bit in the chain twice. For example, if the value expected from the chain is 1010101, the device will output a 11010101. This extra bit will cause some testers to report an erroneous failure for the FLEx72 in a scan test. Therefore the tester should be configured to never enter the PAUSE-DR state.

Boundary Scan Hierarchy for FLEx72 Family

Internally, the CYD04S72V and CYD09S72V have two DIES while CYD18S72V has four DIES. Each DIE contains all the circuitry required to support boundary scan testing. The circuitry includes the TAP, TAP controller, instruction register, and data

Notes

31. CYD04S72V have 16 address bits, CYD09S72V have 17 address bits and CYD18S72V have 18 bits.

32. The "X" in this diagram represents the counter upper bits.

33. Boundary scan is IEEE 1149.1-compatible. See "Performing a Pause/Restart" for deviation from strict 1149.1 compliance.

registers. The circuitry and operation of the DIE boundary scan are described in detail below. The scan chain of each DIE is connected serially to form the scan chain of the FLEx72 family as shown in Figure 3. TMS and TCK are connected in parallel to each DIE to drive all 4 TAP controllers in unison. In many cases, each DIE will be supplied with the same instruction. In other cases, it might be useful to supply different instructions to each DIE. One example would be testing the device ID of one DIE while bypassing the others.

Each pin of FLEx72 family is typically connected to multiple DIES. For connectivity testing with the EXTEST instruction, it is desirable to check the internal connections between DIES as well as the external connections to the package. This can be accomplished by merging the netlist of the devices with the netlist of the user's circuit board. To facilitate boundary scan testing of the devices, Cypress provides the BSDL file for each DIE, the internal netlist of the device, and a description of the device scan chain. The user can use these materials to easily integrate the devices into the board's boundary scan environment. Further information can be found in the Cypress application note [Using JTAG Boundary Scan with the FLEx18/72™ Dual-Port SRAMs](#).

Figure 3. Scan Chain

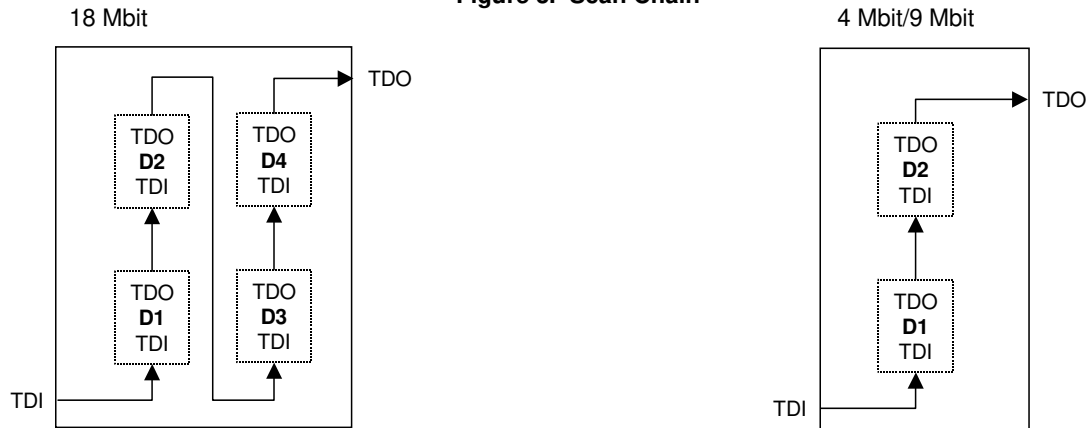

Table 4. Identification Register Definitions

Instruction Field	Value	Description
Revision number(31:28)	0h	Reserved for version number
Cypress device(27:12)	C002h	Defines Cypress DIE number for CYD18S72V and CYD09S72V
	C001h	Defines Cypress DIE number for CYD04S72V
Cypress JDEC ID(11:1)	034h	Allows unique identification of FLEx72 family device vendor
ID register presence (0)	1	Indicates the presence of an ID register

Table 5. Scan Registers Sizes

Register Name	Bit Size
Instruction	4
Bypass	1
Identification	32
Boundary scan	n ^[34]

Table 6. Instruction Identification Codes

Instruction	Code	Description
EXTEST	0000	Captures the Input/Output ring contents. Places the BSR between the TDI and TDO
BYPASS	1111	Places the BYR between TDI and TDO
IDCODE	1011	Loads the IDR with the vendor ID code and places the register between TDI and TDO
HIGHZ	0111	Places BYR between TDI and TDO. Forces all FLEx72 output drivers to a High-Z state
CLAMP	0100	Controls boundary to 1/0. Places BYR between TDI and TDO
SAMPLE/PRELOAD	1000	Captures the input/output ring contents. Places BSR between TDI and TDO
NBSRST	1100	Resets the non-boundary scan logic. Places BYR between TDI and TDO
RESERVED	All other codes	Other combinations are reserved. Do not use other than the above

Note

³⁴. See details in the device BSDL files.

Maximum Ratings^[35]

(Exceeding maximum ratings may shorten the useful life of the device. User guidelines are not tested)

Storage temperature -65 °C to + 150 °C
 Ambient temperature with power applied -55 °C to + 125 °C
 Supply voltage to ground potential -0.5 V to + 4.6 V
 DC Voltage Applied to Outputs in High-Z state -0.5 V to $V_{DD} + 0.5 V$
 DC input voltage -0.5 V to $V_{DD} + 0.5 V$ ^[37]

Output current into outputs (LOW) 20 mA
 Static discharge voltage > 2000 V (JEDEC JESD22-A114-2000B)
 Latch-up current > 200 mA

Operating Range

Range	Ambient Temperature	V_{DD}	V_{CORE} ^[36]
Commercial	0 °C to +70 °C	3.3 V ± 165 mV	1.8 V ± 100 mV
Industrial	-40 °C to +85 °C	3.3 V ± 165 mV	1.8 V ± 100mV

Electrical Characteristics Over the Operating Range

Parameter	Description	Part No.	-167			-133			-100			Unit
			Min	Typ	Max	Min	Typ	Max	Min	Typ	Max	
V_{OH}	Output HIGH voltage ($V_{DD} = \text{Min.}$, $I_{OH} = -4.0 \text{ mA}$)		2.4	-	-	2.4	-	-	2.4	-	-	V
V_{OL}	Output LOW voltage ($V_{DD} = \text{Min.}$, $I_{OL} = +4.0 \text{ mA}$)		-	-	0.4	-	-	0.4	-	-	0.4	V
V_{IH}	Input HIGH voltage		2.0	-	-	2.0	-	-	2.0	-	-	V
V_{IL}	Input LOW voltage		-	-	0.8	-	-	0.8	-	-	0.8	V
I_{OZ}	Output leakage current		-10	-	10	-10	-	10	-10	-	10	µA
I_{IX1}	Input leakage current except TDI, TMS, MRST		-10	-	10	-10	-	10	-10	-	10	µA
I_{IX2}	Input leakage current TDI, TMS, MRST		-0.1	-	1.0	-0.1	-	1.0	-0.1	-	1.0	mA
I_{CC}	Operating current ($V_{DD} = \text{Max.}$, $I_{OUT} = 0 \text{ mA}$), outputs disabled	CYD04S72V	-	225	300	-	-	-	-	-	-	mA
		CYD09S72V	-	-	-	-	350	500	-	-	-	
		CYD18S72V	-	-	-	-	410	580	-	315	450	mA
I_{SB1}	Standby current (both ports TTL level) CE_L and $CE_R \geq V_{IH}$, $f = f_{MAX}$	CYD04S72V	-	90	115	-	-	-	-	-	-	mA
		CYD09S72V	-	-	-	-	105	150	-	-	-	
I_{SB2}	Standby current (one port TTL level) $CE_L CE_R \geq V_{IH}$, $f = f_{MAX}$	CYD04S72V	-	160	210	-	-	-	-	-	-	mA
		CYD09S72V	-	-	-	-	266	380	-	-	-	
I_{SB3}	Standby current (both ports CMOS level) CE_L and $CE_R \geq V_{DD} - 0.2V$, $f = 0$	CYD04S72V	-	55	75	-	-	-	-	-	-	mA
		CYD09S72V	-	-	-	-	55	75	-	-	-	
I_{SB4}	Standby current (one port CMOS level) $CE_L CE_R \geq V_{IH}$, $f = f_{MAX}$	CYD04S72V	-	160	210	-	-	-	-	-	-	mA
		CYD09S72V	-	-	-	-	224	320	-	-	-	
I_{SB5}	Operating current ($V_{DDIO} = \text{Max.}$, $I_{out} = 0 \text{ mA}$, $f = 0$) outputs disabled	CYD18S72V	-	-	-	-	-	75	-	-	75	mA
I_{CORE} ^[36]	Core operating current for ($V_{DD} = \text{Max.}$, $I_{OUT} = 0 \text{ mA}$), outputs disabled		-	0	0	-	0	0	-	0	0	mA

Notes

- 35. The voltage on any input or I/O pin can not exceed the power pin during power-up.
- 36. This family of Dual-Ports does not use V_{CORE} , and these pins are internally NC. The next generation Dual-Port family, the FLEx72-E™, will use V_{CORE} of 1.5 V or 1.8 V. Please contact local Cypress FAE for more information.
- 37. Pulse width < 20 ns.

Capacitance^[38]

Part#	Parameter	Description	Test Conditions	Max	Unit
CYD04S72V CYD09S72V	C _{IN}	Input capacitance	T _A = 25 °C, f = 1 MHz, V _{DD} = 3.3 V	20	pF
	C _{OUT}	Output capacitance		10 ^[39]	pF
CYD18S72V	C _{IN}	Input capacitance		40	pF
	C _{OUT}	Output capacitance		20	pF

AC Test Load and Waveforms

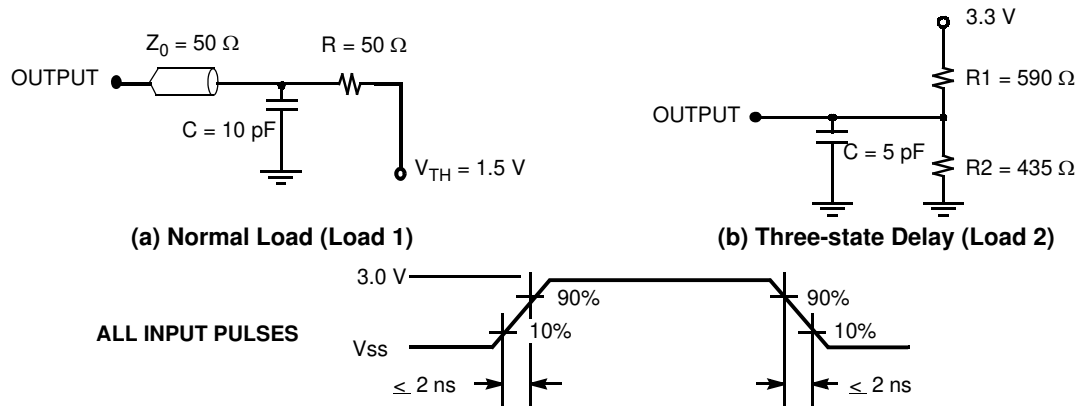

Switching Characteristics Over the Operating Range

Parameter	Description	-167		-133			-100		Unit	
		CYD04S72V		CYD09S72V	CYD18S72V		CYD18S72V			
		Min	Max	Min	Max	Min	Max	Min		Max
f _{MAX2}	Maximum operating frequency	–	167	–	133	–	133	–	100	MHz
t _{CYC2}	Clock cycle time	6.0	–	7.5	–	7.5	–	10	–	ns
t _{CH2}	Clock HIGH time	2.7	–	3.0	–	3.4	–	4.5	–	ns
t _{CL2}	Clock LOW time	2.7	–	3.0	–	3.4	–	4.5	–	ns
t _R ^[40]	Clock rise time	–	2.0	–	2.0	–	2.0	–	3.0	ns
t _F ^[40]	Clock fall time	–	2.0	–	2.0	–	2.0	–	3.0	ns
t _{SA}	Address set-up time	2.3	–	2.5	–	2.2	–	2.7	–	ns
t _{HA}	Address hold time	0.6	–	0.6	–	1.0	–	1.0	–	ns
t _{SB}	Byte select set-up time	2.3	–	2.5	–	2.2	–	2.7	–	ns
t _{HB}	Byte select hold time	0.6	–	0.6	–	1.0	–	1.0	–	ns
t _{SC}	Chip enable set-up time	2.3	–	2.5	–	NA	–	NA	–	ns
t _{HC}	Chip enable hold time	0.6	–	0.6	–	NA	–	NA	–	ns
t _{SW}	R/ \bar{W} set-up time	2.3	–	2.5	–	2.2	–	2.7	–	ns
t _{HW}	R/ \bar{W} hold time	0.6	–	0.6	–	1.0	–	1.0	–	ns
t _{SD}	Input data set-up time	2.3	–	2.5	–	2.2	–	2.7	–	ns
t _{HD}	Input data hold time	0.6	–	0.6	–	1.0	–	1.0	–	ns

Notes

- 38. C_{OUT} also references C_{I/O}.
- 39. Except INT and CNTINT which are 20 pF.
- 40. Except JTAG signal (t_R and t_F < 10 ns max).

Switching Characteristics Over the Operating Range (continued)

Parameter	Description	-167		-133				-100		Unit
		CYD04S72V		CYD09S72V		CYD18S72V		CYD18S72V		
		Min	Max	Min	Max	Min	Max	Min	Max	
t _{SAD}	ADS set-up time	2.3	–	2.5	–	NA	–	NA	–	ns
t _{HAD}	ADS hold time	0.6	–	0.6	–	NA	–	NA	–	ns
t _{SCN}	CNTEN set-up time	2.3	–	2.5	–	NA	–	NA	–	ns
t _{HCN}	CNTEN hold time	0.6	–	0.6	–	NA	–	NA	–	ns
t _{SRST}	CNTRST set-up time	2.3	–	2.5	–	NA	–	NA	–	ns
t _{HRST}	CNTRST hold time	0.6	–	0.6	–	NA	–	NA	–	ns
t _{SCM}	CNT/MSK set-up time	2.3	–	2.5	–	NA	–	NA	–	ns
t _{HCM}	CNT/MSK hold time	0.6	–	0.6	–	NA	–	NA	–	ns
t _{OE}	Output enable to data valid	–	4.0	–	4.4	–	5.5	–	5.5	ns
t _{OLZ} ^[41, 42]	OE to Low Z	0	–	0	–	0	–	0	–	ns
t _{OHZ} ^[41, 42]	OE to High Z	0	4.0	0	4.4	0	5.5	0	5.5	ns
t _{CD2}	Clock to data valid	–	4.0	–	4.4	–	5.0	–	5.2	ns
t _{CA2}	Clock to counter address valid	–	4.0	–	4.4	–	NA	–	NA	ns
t _{CM2}	Clock to mask register readback valid	–	4.0	–	4.4	–	NA	–	NA	ns
t _{DC}	Data output hold after clock HIGH	1.0	–	1.0	–	1.0	–	1.0	–	ns
t _{CKHZ} ^[41, 42]	Clock HIGH to output High Z	0	4.0	0	4.4	0	4.7	0	5.0	ns
t _{CKLZ} ^[41, 42]	Clock HIGH to output Low Z	1.0	4.0	1.0	4.4	1.0	4.7	1.0	5.0	ns
t _{SINT}	Clock to INT set time	0.5	6.7	0.5	7.5	0.5	7.5	0.5	10	ns
t _{RINT}	Clock to INT reset time	0.5	6.7	0.5	7.5	0.5	7.5	0.5	10	ns
t _{SCINT}	Clock to CNTINT set time	0.5	5.0	0.5	5.7	NA	NA	NA	NA	ns
t _{RCINT}	Clock to CNTINT reset time	0.5	5.0	0.5	5.7	NA	NA	NA	NA	ns
Port to Port Delays										
t _{CCS}	Clock to clock skew	5.2	–	6.0	–	5.7	–	8.0	–	ns
Master Reset Timing										
t _{RS}	Master reset pulse width	5.0	–	5.0	–	5.0	–	5.0	–	cycles
t _{RSS}	Master reset set-up time	6.0	–	6.0	–	6.0	–	8.5	–	ns
t _{RSR}	Master reset recovery time	5.0	–	5.0	–	5.0	–	5.0	–	cycles
t _{RSF}	Master Reset to outputs inactive	–	10.0	–	10.0	–	10.0	–	10.0	ns
t _{RSCNTINT}	Master reset to counter interrupt flag reset time	–	10.0	–	10.0	–	NA	–	NA	ns

Notes

- 41. This parameter is guaranteed by design, but is not production tested.
- 42. Test conditions used are Load 2.

JTAG Timing Characteristics

Parameter	Description	CYD04S72V CYD09S72V CYD18S72V		Unit
		-167/-133/-100		
		Min	Max	
f_{JTAG}	Maximum JTAG TAP controller frequency	–	10	MHz
t_{TCYC}	TCK clock cycle time	100	–	ns
t_{TH}	TCK clock HIGH time	40	–	ns
t_{TL}	TCK clock LOW time	40	–	ns
t_{TMSS}	TMS set-up to TCK clock rise	10	–	ns
t_{TMSH}	TMS hold after TCK clock rise	10	–	ns
t_{TDIS}	TDI set-up to TCK clock rise	10	–	ns
t_{TDIH}	TDI hold after TCK clock rise	10	–	ns
t_{TDOV}	TCK clock LOW to TDO valid	–	30	ns
t_{TDOX}	TCK clock LOW to TDO invalid	0	–	ns

Switching Waveforms

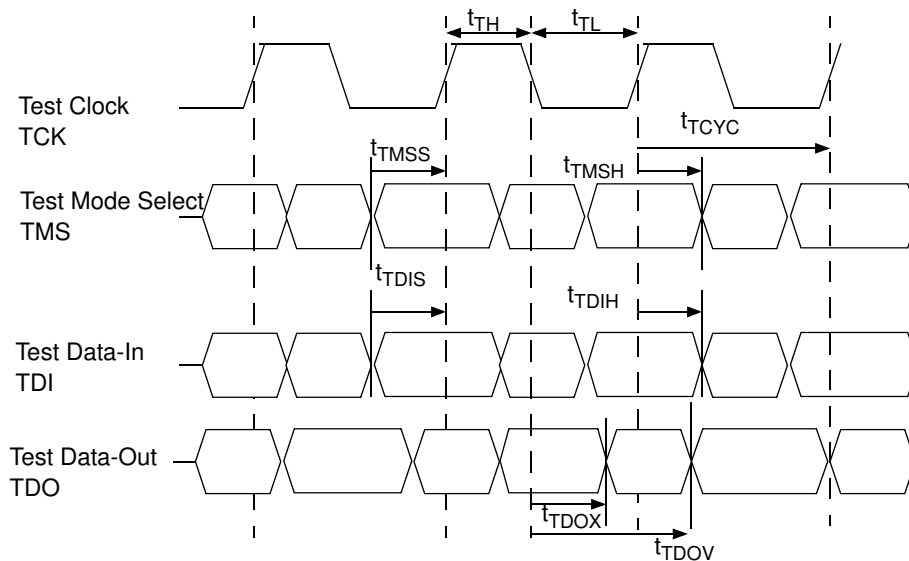

Switching Waveforms (continued)

Figure 4. Master Reset

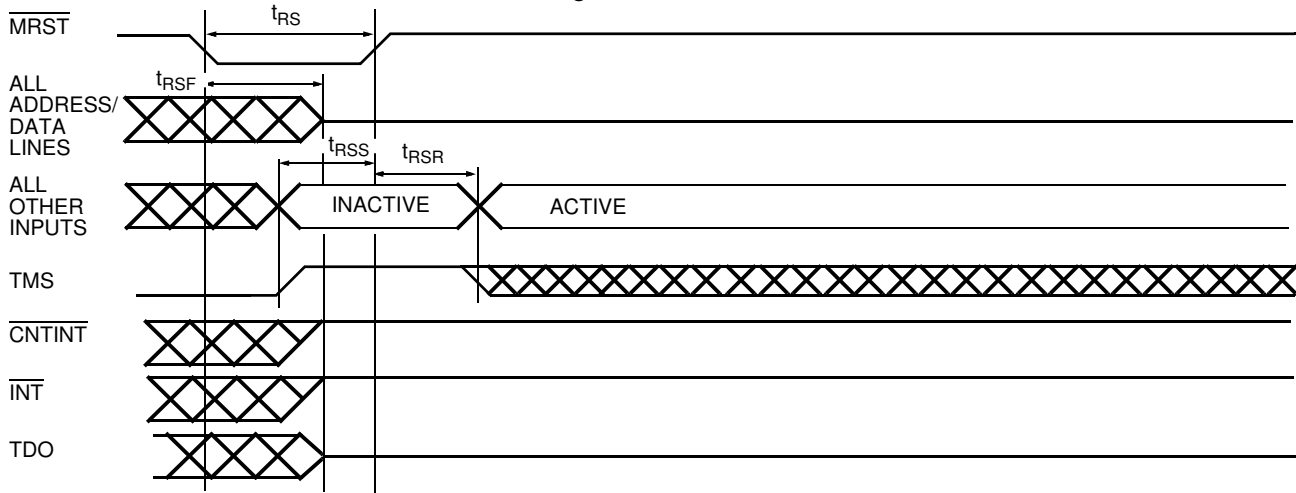
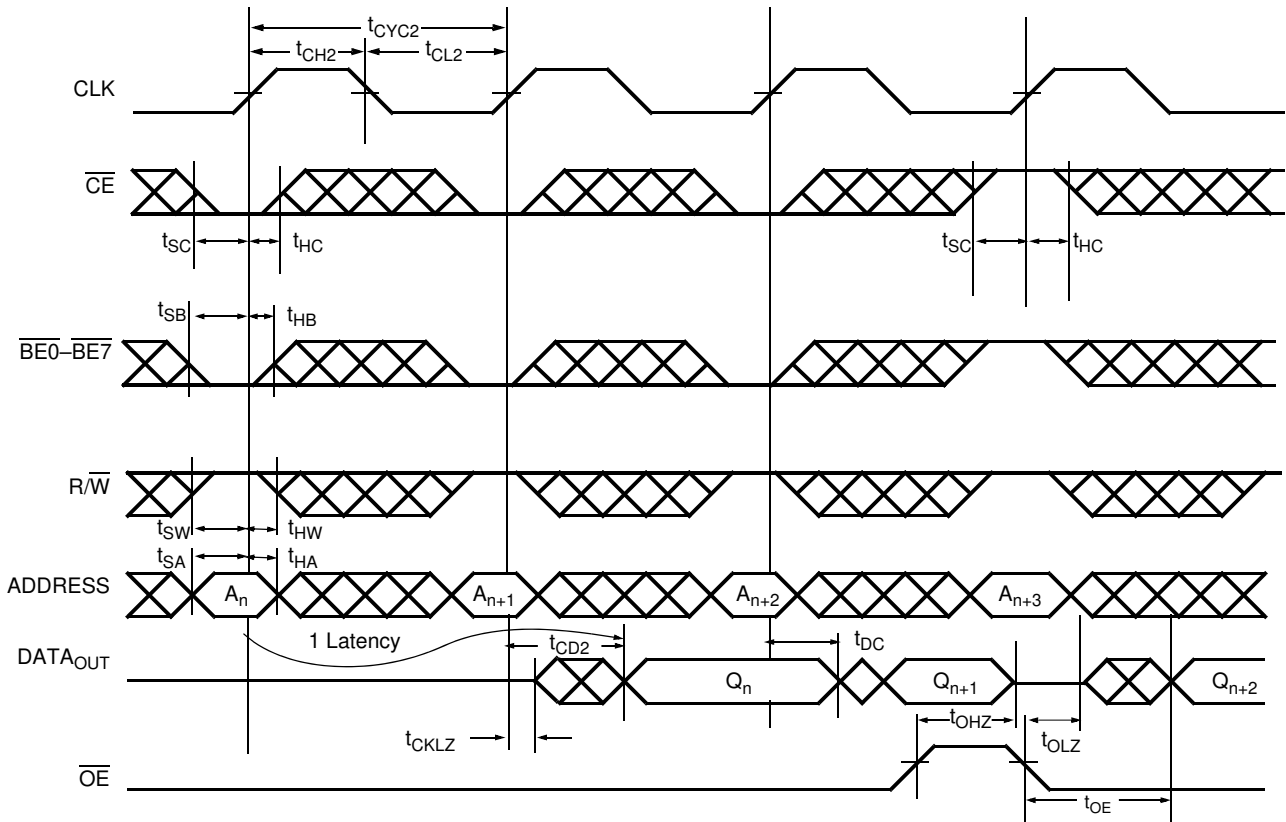

Figure 5. Read Cycle^[43, 44, 45, 46, 47]



Notes

43. CE is internal signal. $\overline{CE} = \text{LOW}$ if $\overline{CE}_0 = \text{LOW}$ and $CE_1 = \text{HIGH}$. For a single Read operation, CE only needs to be asserted once at the rising edge of the CLK and can be deasserted after that. Data will be out after the following CLK edge and will be three-stated after the next CLK edge.
44. \overline{OE} is asynchronously controlled; all other inputs (excluding MRST and JTAG) are synchronous to the rising clock edge.
45. $\overline{ADS} = \overline{\text{CNTEN}} = \text{LOW}$, and $\overline{\text{MRST}} = \overline{\text{CNTNST}} = \overline{\text{CNT/MSK}} = \text{HIGH}$.
46. The output is disabled (high-impedance state) by $\overline{CE} = V_{IH}$ following the next rising edge of the clock.
47. Addresses do not have to be accessed sequentially since $\overline{\text{ADS}} = \overline{\text{CNTEN}} = V_{IL}$ with $\overline{\text{CNT/MSK}} = V_{IH}$ constantly loads the address on the rising edge of the CLK. Numbers are for reference only.

Switching Waveforms (continued)

Figure 6. Bank Select Read^[48, 49]

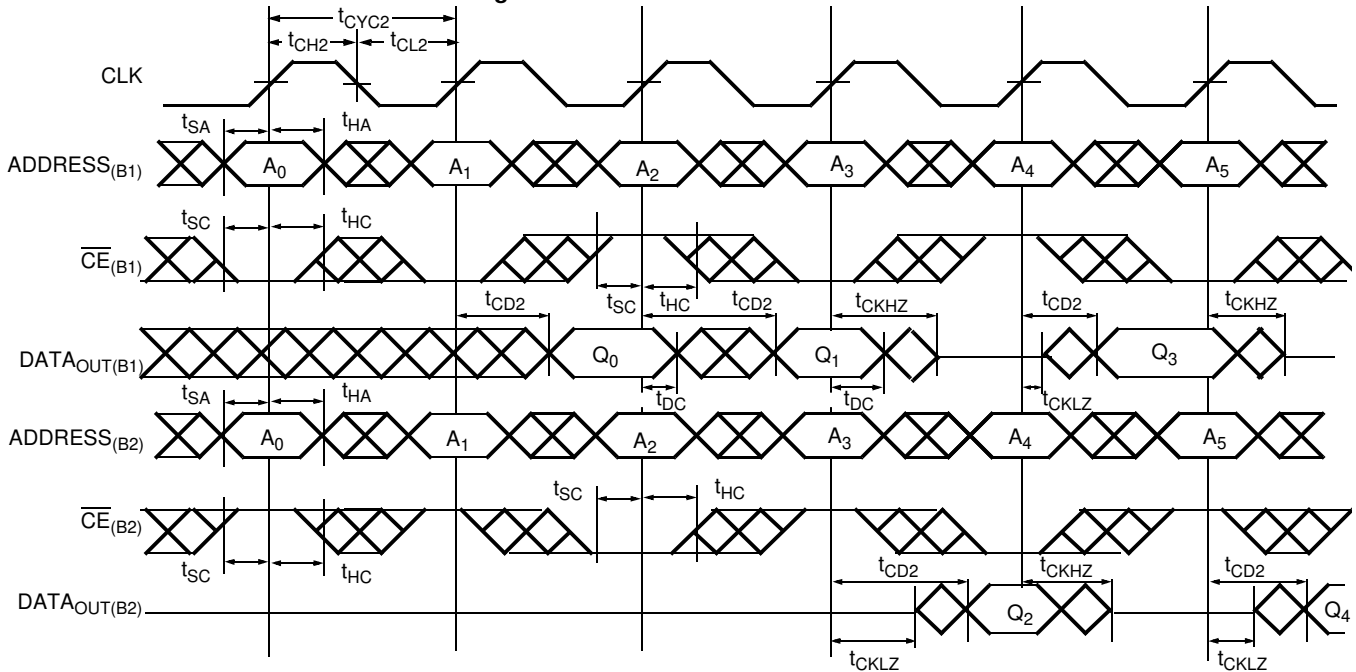
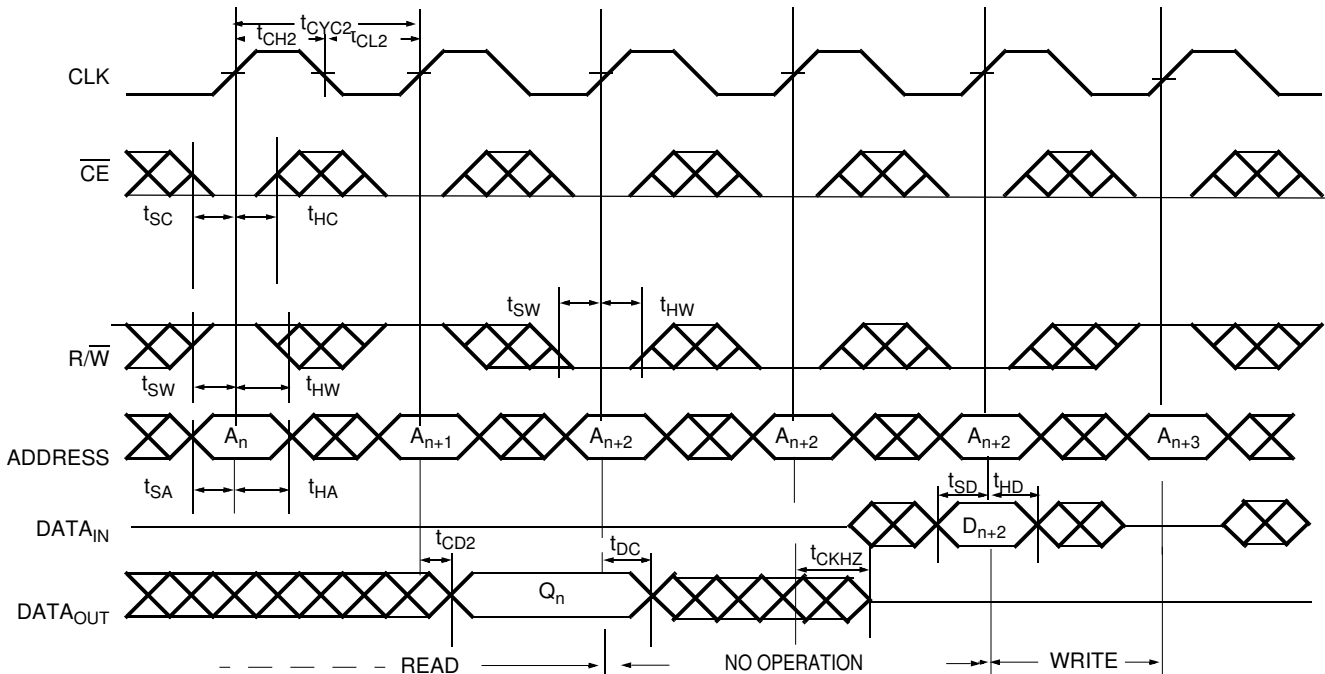

Figure 7. Read-to-Write-to-Read ($\overline{OE} = \text{LOW}$)^[47, 50, 51, 52, 53]



Notes

- 48. In this depth-expansion example, B1 represents Bank #1 and B2 is Bank #2; each bank consists of one Cypress FLEx72 device from this data sheet. ADDRESS_(B1) = ADDRESS_(B2).
- 49. ADS = CNTEN = BE0 – BE7 = OE = LOW; MRST = CNTRST = CNT/MSK = HIGH.
- 50. Output state (HIGH, LOW, or high-impedance) is determined by the previous cycle control signals.
- 51. During “No Operation,” data in memory at the selected address may be corrupted and should be rewritten to ensure data integrity.
- 52. CE₀ = OE = BE0 – BE7 = LOW; CE₁ = R/W = CNTRST = MRST = HIGH.
- 53. CE₀ = BE0 – BE7 = R/W = LOW; CE₁ = CNTRST = MRST = CNT/MSK = HIGH. When R/W first switches low, since OE = LOW, the Write operation cannot be completed (labelled as no operation). One clock cycle is required to three-state the I/O for the Write operation on the next rising edge of CLK.

Switching Waveforms (continued)

Figure 8. Read-to-Write-to-Read (\overline{OE} Controlled)^[54, 55, 56, 57]

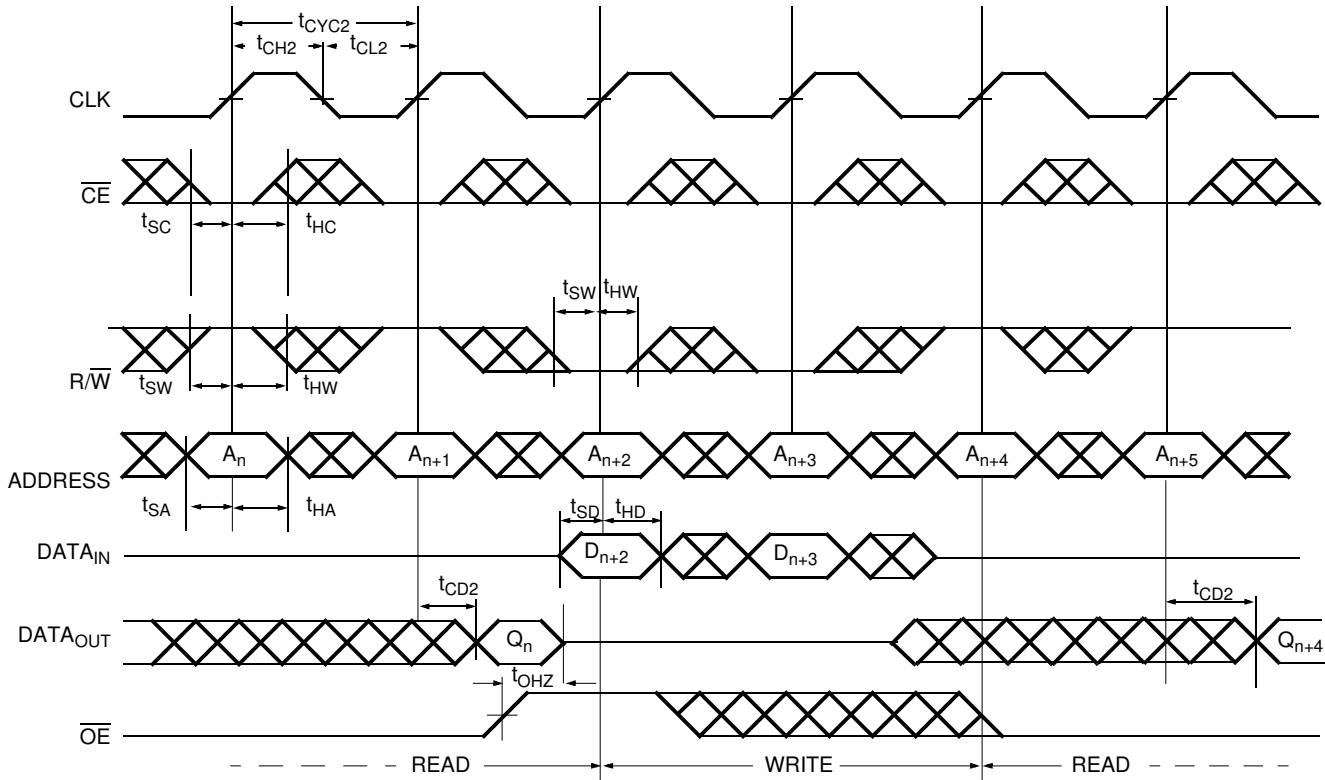
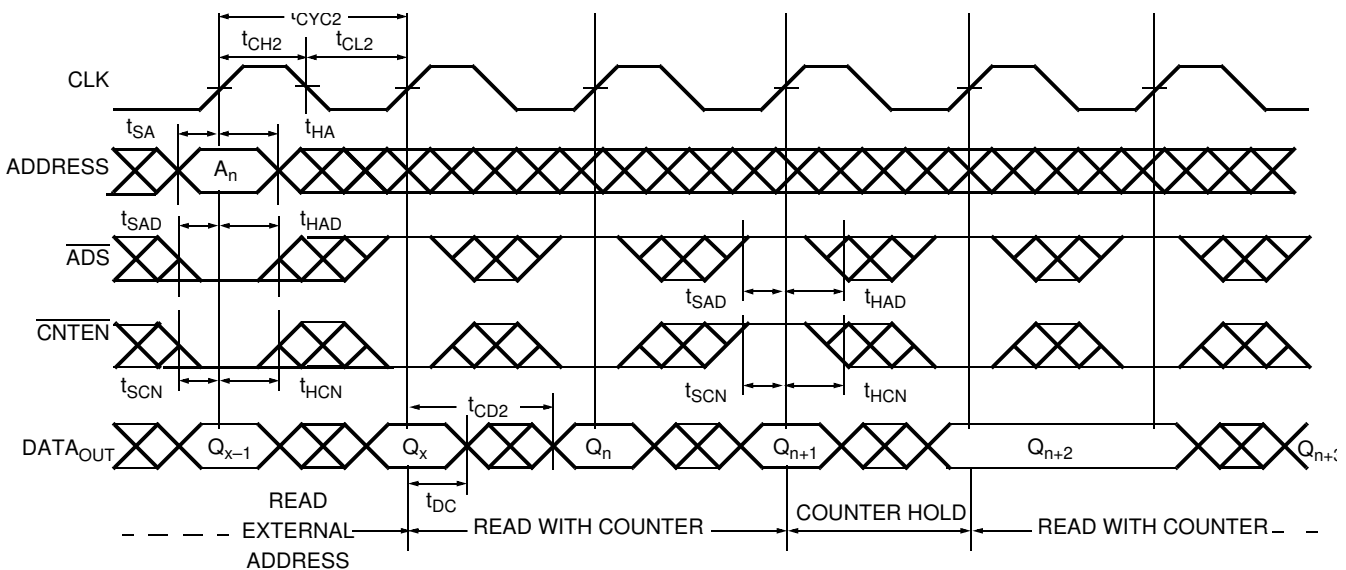

Figure 9. Read with Address Counter Advance^[56]



Notes

- 54. Addresses do not have to be accessed sequentially since $\overline{ADS} = \overline{CNTEN} = V_{IL}$ with $CNT/\overline{MSK} = V_{IH}$ constantly loads the address on the rising edge of the CLK. Numbers are for reference only.
- 55. Output state (HIGH, LOW, or high-impedance) is determined by the previous cycle control signals.
- 56. $\overline{CE}_0 = \overline{OE} = \overline{BE}_0 - \overline{BE}_7 = \text{LOW}$; $\overline{CE}_1 = \overline{R/W} = \overline{CNT\overline{RST}} = \overline{MRST} = \text{HIGH}$
- 57. $\overline{CE}_0 = \overline{BE}_0 - \overline{BE}_7 = \overline{R/W} = \text{LOW}$; $\overline{CE}_1 = \overline{CNT\overline{RST}} = \overline{MRST} = \overline{CNT/\overline{MSK}} = \text{HIGH}$. When $\overline{R/W}$ first switches low, since $\overline{OE} = \text{LOW}$, the Write operation cannot be completed (labelled as no operation). One clock cycle is required to three-state the I/O for the Write operation on the next rising edge of CLK.

Switching Waveforms (continued)

Figure 10. Write with Address Counter Advance^[58]

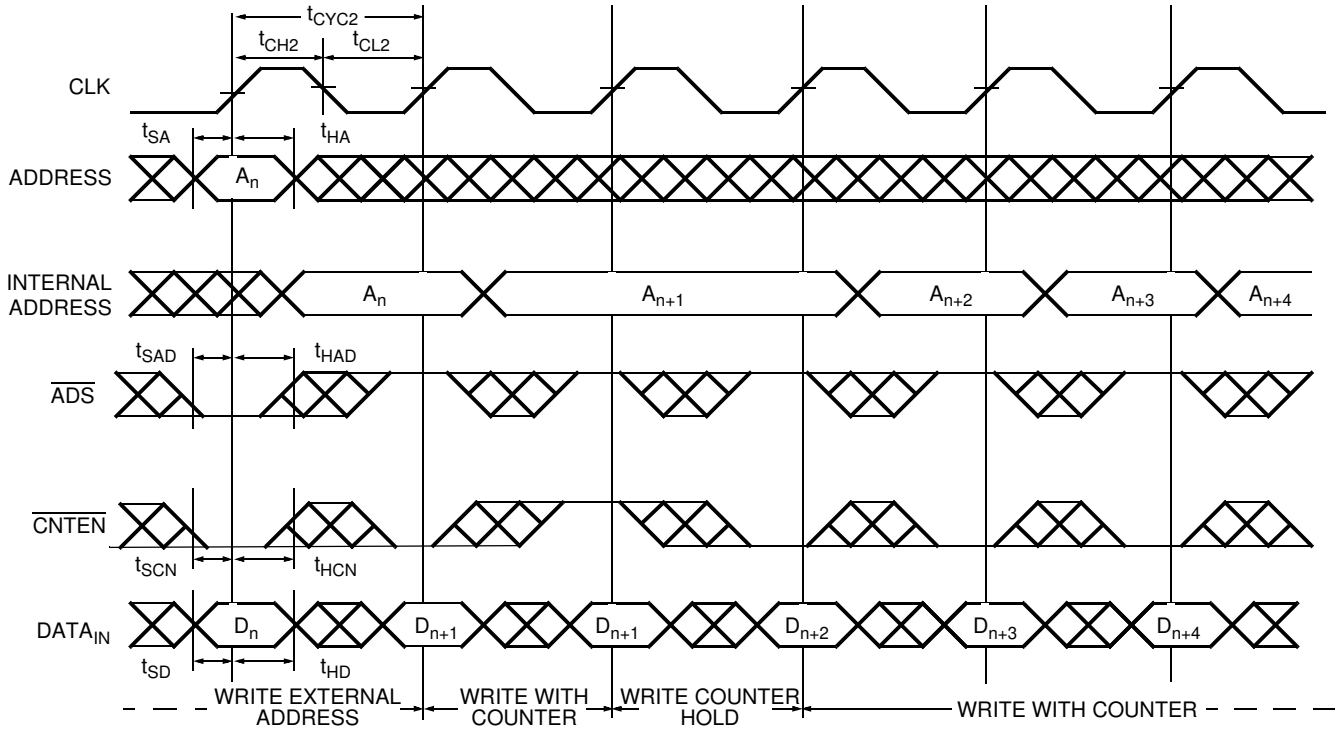

Note

58. $\overline{CE}_0 = \overline{BE}_0 - \overline{BE}_7 = R/\overline{W} = \text{LOW}$; $CE_1 = \overline{CNTRST} = \overline{MRST} = \overline{CNT/MSK} = \text{HIGH}$. When R/\overline{W} first switches low, since $OE = \text{LOW}$, the Write operation cannot be completed (labelled as no operation). One clock cycle is required to three-state the I/O for the Write operation on the next rising edge of CLK.

Switching Waveforms (continued)

Figure 11. Counter Reset [59, 60]

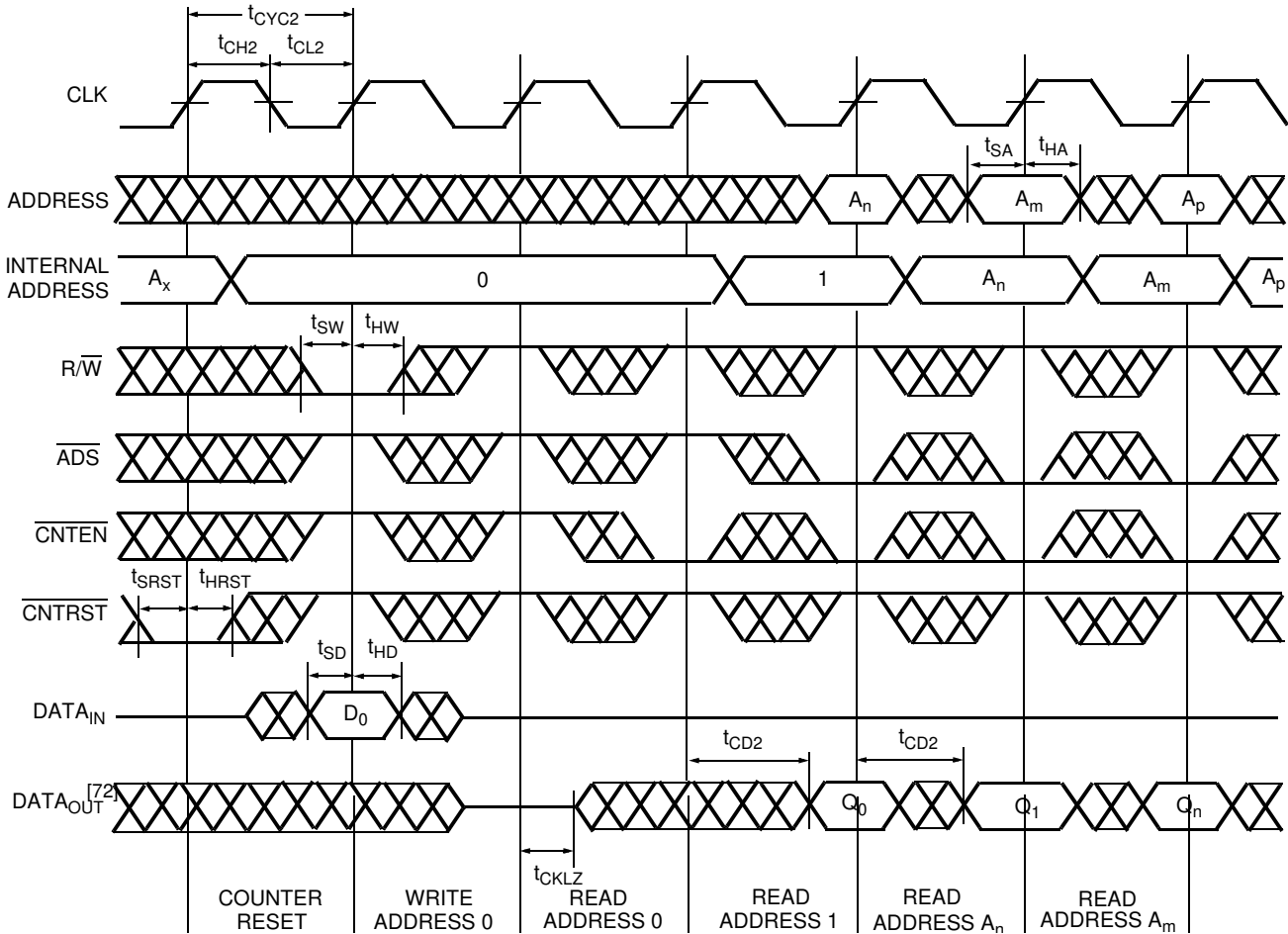

Notes

59. $\overline{CE}_0 = \overline{BE}_0 - \overline{BE}_7 = \text{LOW}$; $\overline{CE}_1 = \overline{MRST} = \overline{CNT/MSK} = \text{HIGH}$.

60. No dead cycle exists during counter reset. A Read or Write cycle may be coincidental with the counter reset.

Switching Waveforms (continued)

Figure 12. Readback State of Address Counter or Mask Register^[61, 62, 63, 64]

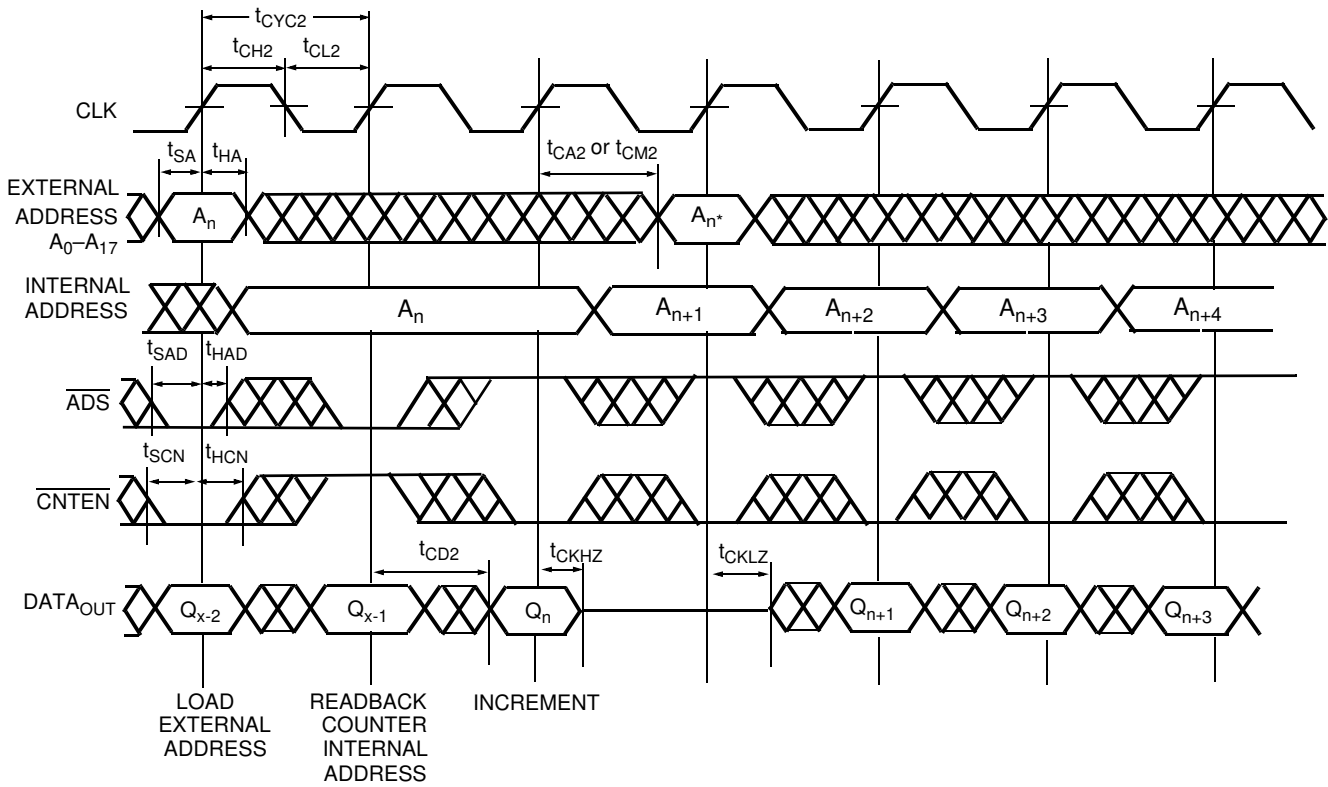

Notes

- 61. $\overline{CE_0} = \overline{OE} = \overline{BE_0} - \overline{BE_7} = \text{LOW}$; $CE_1 = R/\overline{W} = \overline{CNTRST} = \overline{MRST} = \text{HIGH}$.
- 62. Address in output mode. Host must not be driving address bus after t_{CKLZ} in next clock cycle.
- 63. Address in input mode. Host can drive address bus after t_{CKHZ}.
- 64. A_n * is the internal value of the address counter (or the mask register depending on the CNT/ \overline{MSK} level) being Read out on the address lines.

Switching Waveforms (continued)

Figure 13. Left_Port (L_Port) Write to Right_Port (R_Port) Read^[65, 66, 67]

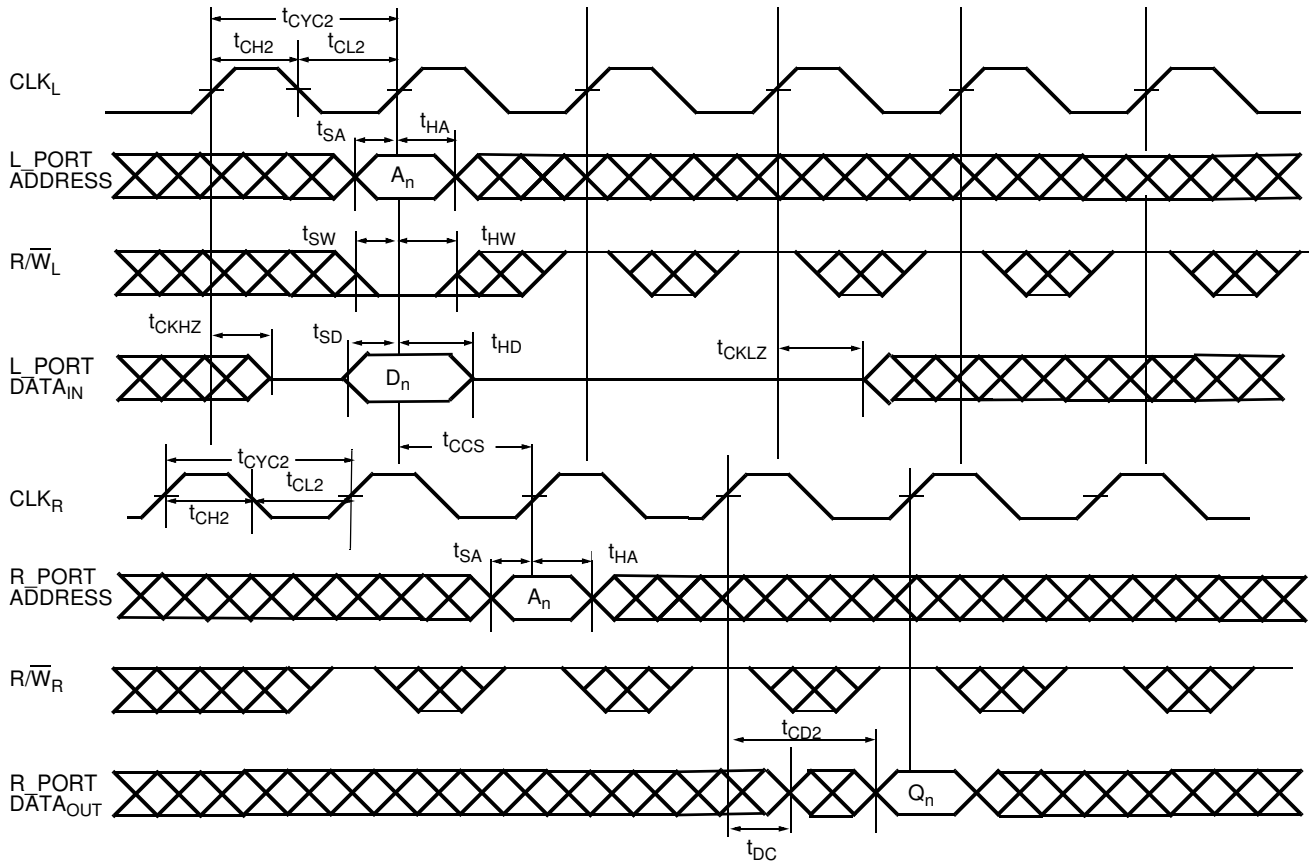

Notes

65. $\overline{CE}_0 = \overline{OE} = \overline{ADS} = \overline{CNTEN} = \overline{BE}_0 - \overline{BE}_7 = \text{LOW}$; $CE_1 = \overline{CNTRST} = \overline{MRST} = \overline{CNT/MSK} = \text{HIGH}$.

66. This timing is valid when one port is writing, and other port is reading the same location at the same time. If t_{CCS} is violated, indeterminate data will be Read out.

67. If $t_{CCS} <$ minimum specified value, then R_Port will Read the most recent data (written by L_Port) only ($2 * t_{CYC2} + t_{CD2}$) after the rising edge of R_Port's clock. If $t_{CCS} \geq$ minimum specified value, then R_Port will Read the most recent data (written by L_Port) ($t_{CYC2} + t_{CD2}$) after the rising edge of R_Port's clock.

Switching Waveforms (continued)

Figure 14. Counter Interrupt and Retransmit^[68, 69, 70, 71, 72]

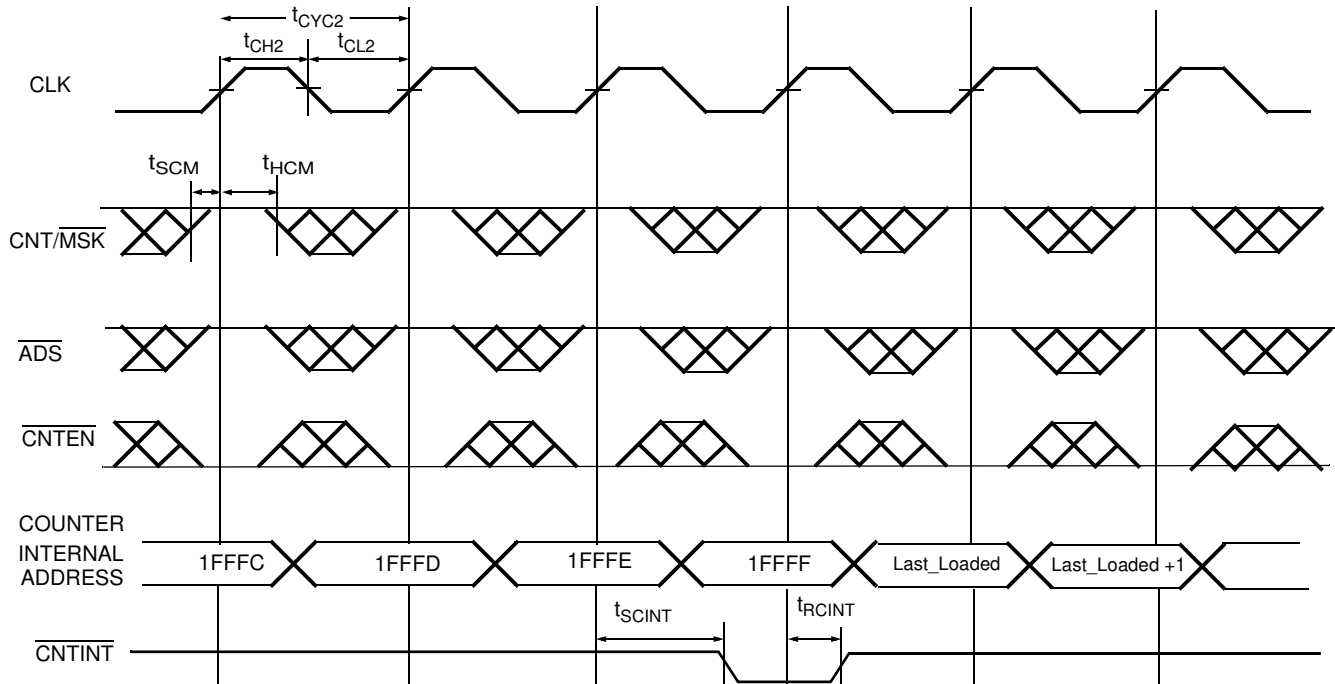
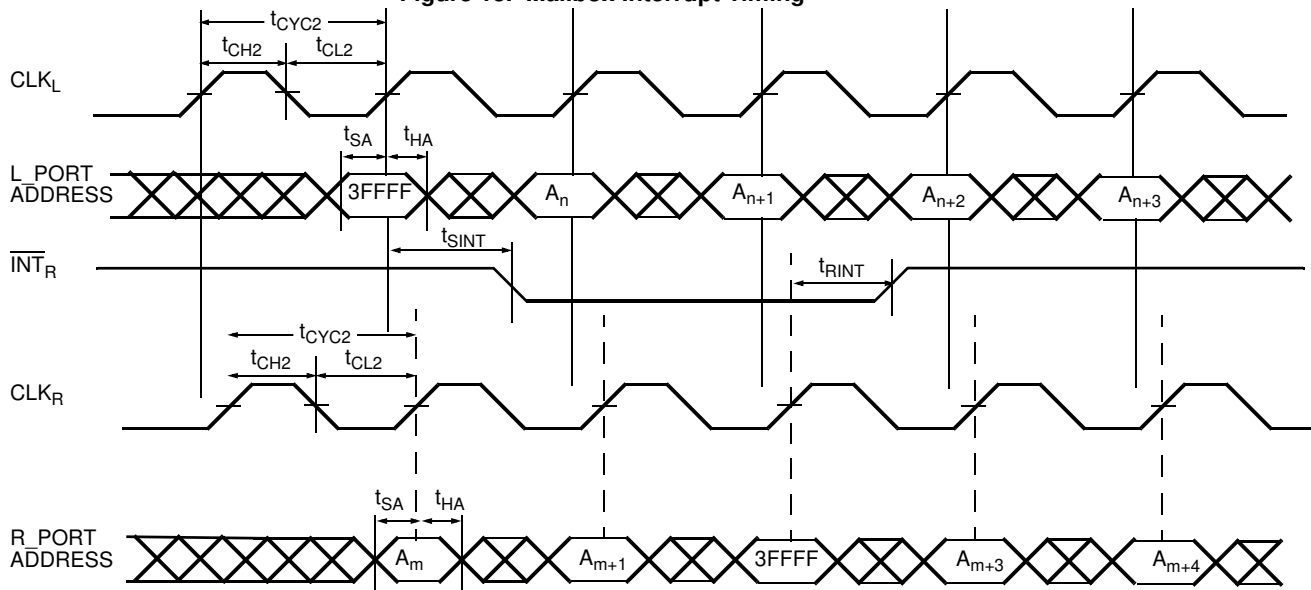





Figure 15. Mailbox Interrupt Timing^[73, 74, 75, 76, 77]



Notes

- 68. $\overline{CE}_0 = \overline{OE} = \overline{BE}_0 - \overline{BE}_7 = \text{LOW}$; $\overline{CE}_1 = \text{R}/\overline{\text{W}} = \overline{\text{CNRST}} = \overline{\text{MRST}} = \text{HIGH}$.
- 69. $\overline{\text{CNTINT}}$ is always driven.
- 70. $\overline{\text{CNTINT}}$ goes LOW when the unmasked portion of the address counter is incremented to the maximum value.
- 71. The mask register assumed to have the value of 1FFFFh.
- 72. Retransmit happens if the counter remains in increment mode after it wraps to initially loaded value.
- 73. $\overline{CE}_0 = \overline{OE} = \overline{\text{ADS}} = \overline{\text{CNTEN}} = \text{LOW}$; $\overline{CE}_1 = \overline{\text{CNRST}} = \overline{\text{MRST}} = \overline{\text{CNT/MSK}} = \text{HIGH}$.
- 74. Address "1FFFF" is the mailbox location for R_Port.
- 75. L_Port is configured for Write operation, and R_Port is configured for Read operation.
- 76. At least one byte enable ($\overline{\text{B0}} - \overline{\text{B3}}$) is required to be active during interrupt operations.
- 77. Interrupt flag is set with respect to the rising edge of the Write clock, and is reset with respect to the rising edge of the Read clock.

Table 7. Read/Write and Enable Operation (Any Port) [78, 79, 80, 81, 82]

Inputs					Outputs	Operation
\overline{OE}	CLK	\overline{CE}_0	CE_1	R/W	DQ ₀ – DQ ₇₁	
X		H	X	X	High-Z	Deselected
X		X	L	X	High-Z	Deselected
X		L	H	L	D _{IN}	Write
L		L	H	H	D _{OUT}	Read
H	X	L	H	X	High-Z	Outputs disabled

Notes

78. CYD04S72V have 16 address bits, CYD09S72V have 17 address bits and CYD18S72V have 18 bits.

79. X" = "Don't Care," "H" = HIGH, "L" = LOW.

80. \overline{OE} is an asynchronous input signal.

81. When \overline{OE} changes state, deselection and Read happen after one cycle of latency.

82. $\overline{CE}_0 = \overline{OE} = \text{LOW}$; $CE_1 = \text{R/W} = \text{HIGH}$.

Ordering Information

Speed (MHz)	Ordering Code	Package Name	Package Type	Operating Range
256K x 72 (18-Mbit) 3.3 V Synchronous CYD18S72V Dual-Port SRAM				
133	CYD18S72V-133BBI	BB484	484-ball Ball Grid Array 23 mm x 23 mm with 1.0-mm pitch (FBGA)	Industrial
100	CYD18S72V-100BBC	BB484	484-ball Ball Grid Array 23 mm x 23 mm with 1.0-mm pitch (FBGA)	Commercial
	CYD18S72V-100BBI	BB484	484-ball Ball Grid Array 23 mm x 23 mm with 1.0-mm pitch (FBGA)	Industrial
128K x 72 (9-Mbit) 3.3 V Synchronous CYD09S72V Dual-Port SRAM				
133	CYD09S72V-133BBC	BB484	484-ball Ball Grid Array 23 mm x 23 mm with 1.0-mm pitch (FBGA)	Commercial
64K x 72 (4-Mbit) 3.3 V Synchronous CYD04S72V Dual-Port SRAM				
167	CYD04S72V-167BBC	BB484	484-ball Ball Grid Array 23 mm x 23 mm with 1.0-mm pitch (FBGA)	Commercial

Ordering Code Definitions

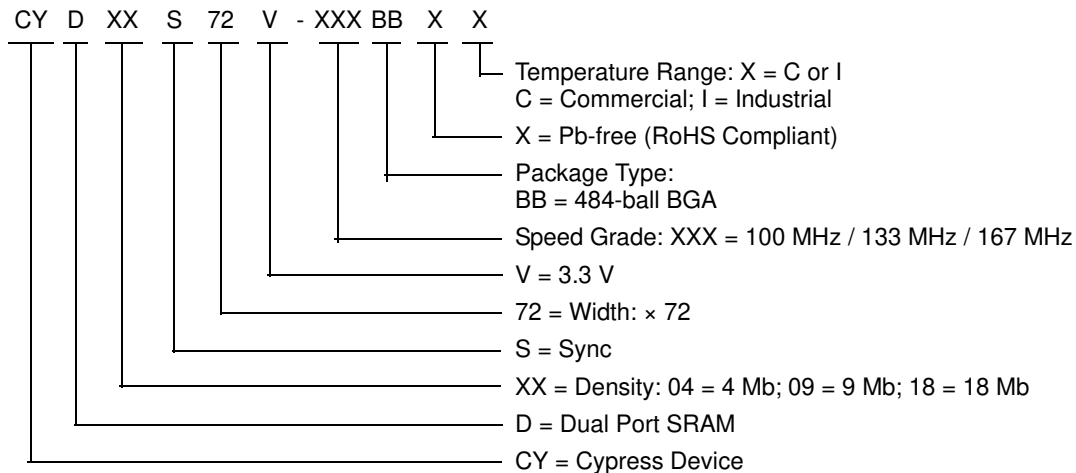

Package Diagram

Dimensions in mm
 Reference Jedec MO-192
 Package Weight – 1.3 grams

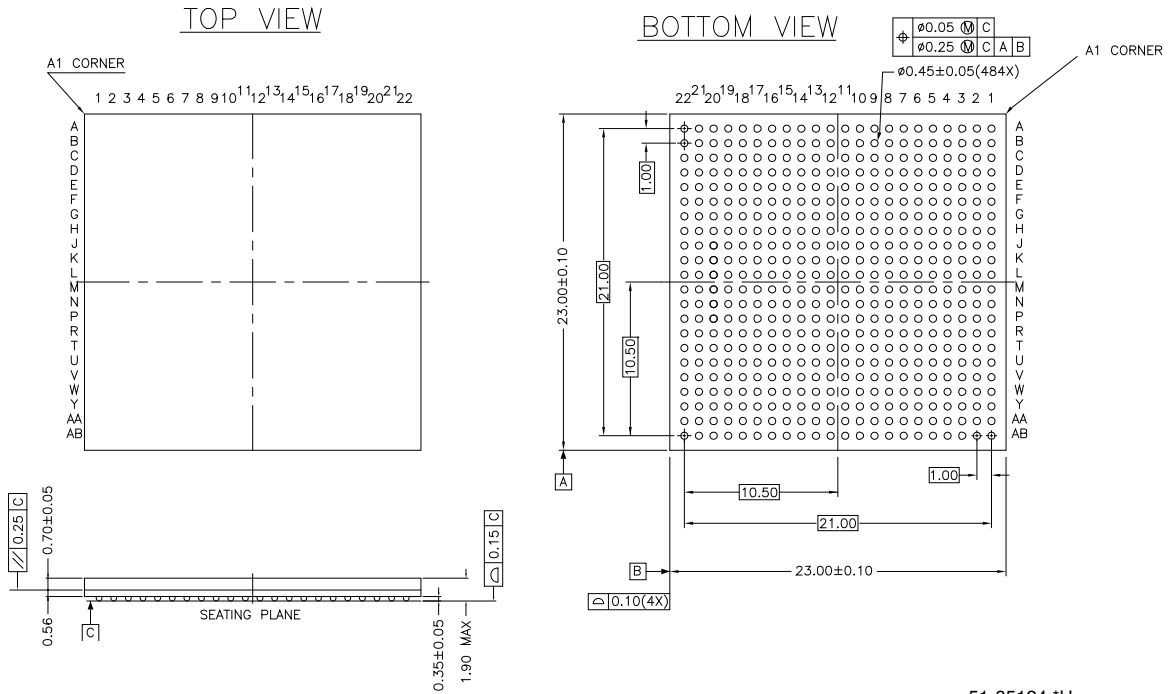

51-85124 *H

Acronyms

Acronym	Description
CMOS	Complementary metal oxide semiconductor
FBGA	fine-pitch ball grid array
JTAG	joint test action group
OE	Output enable
RAM	Random access memory

Document Conventions

Units of Measure

Symbol	Unit of Measure
°C	degree Celcius
MHz	megahertz
μA	microamperes
mA	milliamperes
mV	millivolts
mW	milliwatts
ns	nanoseconds
pF	picofarad
V	volts
W	watts

Document History Page

Document Title: CYD04S72V / CYD09S72V / CYD18S72V FLE _x 72™ 3.3 V 64 K/128 K/256 K × 72 Synchronous Dual-Port RAM				
Document Number: 38-06069				
REV.	ECN NO.	Issue Date	Orig. of Change	Description of Change
**	125859	06/17/03	SPN	New Data Sheet
*A	128707	08/01/03	SPN	Added -133 speed bin Updated spec values for I _{CC} , t _{HA} , t _{HB} , t _{HW} , t _{HD} Added new parameter I _{CC1} Added bank select read and read to write to read (\overline{OE} =low) timing diagrams
*B	128997	09/18/03	SPN	Updated spec values for t _{OE} , t _{OHZ} , t _{CH2} , t _{CL2} , t _{HA} , t _{HB} , t _{HW} , t _{HD} , I _{CC} , I _{SB5} , t _{SA} , t _{SB} , t _{sw} , t _{SD} , t _{CD2} Updated read to write (\overline{OE} =low) timing diagram Updated Master Reset values for t _{RS} , t _{RSR} , t _{RSF} Updated pinout Updated V _{CORE} voltage range
*C	129936	09/30/03	SPN	Updated package diagram Updated t _{CD2} value on first page Removed Preliminary status
*D	233830	See ECN	WWZ	Added 4 Mbit and 9 Mbit x72 devices into the data sheet with updated pinout, pin description table, power table, and timing table Changed title Added Preliminary status to reflect the addition of 4 Mbit and 9 Mbit devices Removed FLE _x 72-E from the document Added counter related functions for 4 Mbit and 9 Mbit Removed standard JTAG description Updated block diagram Updated pinout with FTSEL and one more PORTSTD pins per port Updated tRSF of CYD18S72V value
*E	288892	See ECN	WWZ	Change pinout D15 from REV[2,4] to VSS to reflect SC pin removal
*F	327355	See ECN	AEQ	Changed pinout K3 from NC to NC[2,5] Changed pinout K20 from NC to NC[2,5] Changed pinout D15 from VSS to NC Changed pinout D8 and M3 from REVL[2,4] to VSS Changed pinout M20 and W15 from REVR[2,4] to VSS
*G	345735	See ECN	PCX	VREF Pin Definition Updated Added Pb-Free Part Ordering Informations
*H	360316	See ECN	YDT	Added note for V _{CORE} Changed notes for PORTSTD to VSS Changed ICC, ISB1, ISB2 and ISB4 number for CYD09S72V per PE request
*I	460454	See ECN	YDT	Changed CYDxxS72AV to CYDxxS72V (rev. A not implemented)
*J	2898491	07/01/10	AJU	Removed inactive parts from Ordering Information. Updated Packaging Information
*K	3110296	12/14/2010	ADMU	Updated Ordering Information . Added Ordering Code Definitions .
*L	3265044	05/25/2011	ADMU	Updates link to Application note. Removed obsolete part information. Notes updated across datasheet as per template. Added Acronyms and Units of measure table.
*M	3402091	10/12/2011	ADMU	Removed pruned part CYD18S72V-133BBC from Ordering Information Updated Package Diagram

Sales, Solutions, and Legal Information

Worldwide Sales and Design Support

Cypress maintains a worldwide network of offices, solution centers, manufacturer's representatives, and distributors. To find the office closest to you, visit us at [Cypress Locations](#).

Products

Automotive	cypress.com/go/automotive
Clocks & Buffers	cypress.com/go/clocks
Interface	cypress.com/go/interface
Lighting & Power Control	cypress.com/go/powerpsoc cypress.com/go/plc
Memory	cypress.com/go/memory
Optical & Image Sensing	cypress.com/go/image
PSoC	cypress.com/go/psoc
Touch Sensing	cypress.com/go/touch
USB Controllers	cypress.com/go/USB
Wireless/RF	cypress.com/go/wireless

PSoC Solutions

[psoc.cypress.com/solutions](#)
PSoC 1 | PSoC 3 | PSoC 5

© Cypress Semiconductor Corporation, 2003-2011. The information contained herein is subject to change without notice. Cypress Semiconductor Corporation assumes no responsibility for the use of any circuitry other than circuitry embodied in a Cypress product. Nor does it convey or imply any license under patent or other rights. Cypress products are not warranted nor intended to be used for medical, life support, life saving, critical control or safety applications, unless pursuant to an express written agreement with Cypress. Furthermore, Cypress does not authorize its products for use as critical components in life-support systems where a malfunction or failure may reasonably be expected to result in significant injury to the user. The inclusion of Cypress products in life-support systems application implies that the manufacturer assumes all risk of such use and in doing so indemnifies Cypress against all charges.

Any Source Code (software and/or firmware) is owned by Cypress Semiconductor Corporation (Cypress) and is protected by and subject to worldwide patent protection (United States and foreign), United States copyright laws and international treaty provisions. Cypress hereby grants to licensee a personal, non-exclusive, non-transferable license to copy, use, modify, create derivative works of, and compile the Cypress Source Code and derivative works for the sole purpose of creating custom software and or firmware in support of licensee product to be used only in conjunction with a Cypress integrated circuit as specified in the applicable agreement. Any reproduction, modification, translation, compilation, or representation of this Source Code except as specified above is prohibited without the express written permission of Cypress.

Disclaimer: CYPRESS MAKES NO WARRANTY OF ANY KIND, EXPRESS OR IMPLIED, WITH REGARD TO THIS MATERIAL, INCLUDING, BUT NOT LIMITED TO, THE IMPLIED WARRANTIES OF MERCHANTABILITY AND FITNESS FOR A PARTICULAR PURPOSE. Cypress reserves the right to make changes without further notice to the materials described herein. Cypress does not assume any liability arising out of the application or use of any product or circuit described herein. Cypress does not authorize its products for use as critical components in life-support systems where a malfunction or failure may reasonably be expected to result in significant injury to the user. The inclusion of Cypress' product in a life-support systems application implies that the manufacturer assumes all risk of such use and in doing so indemnifies Cypress against all charges.

Use may be limited by and subject to the applicable Cypress software license agreement.